

Feb. 6, 1945.

M. CAMRAS

2,369,017

MAGNETIC RECORDER AND DRIVE THEREFOR

Filed Feb. 25, 1943

3 Sheets-Sheet 1

Fig-1

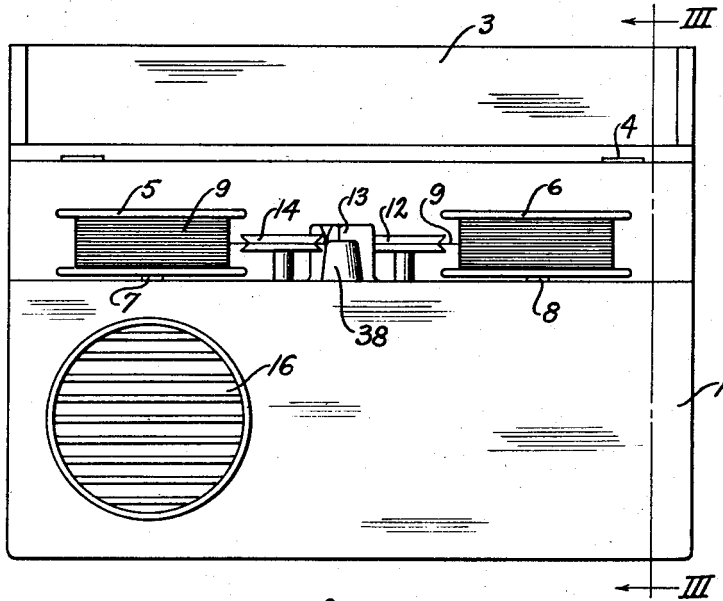

Fig-6

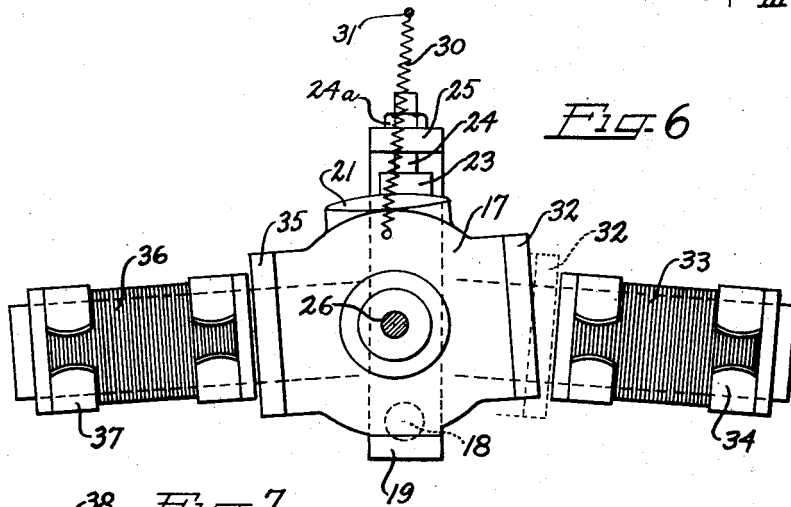
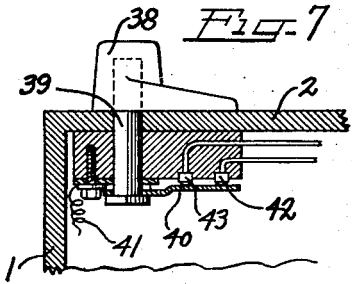

Fig-7



INVENTOR  
MARVIN CAMRAS

By Charles W. Hill ATTYS.

Feb. 6, 1945.

M. CAMRAS

2,369,017

MAGNETIC RECORDER AND DRIVE THEREFOR

Filed Feb. 25, 1943

3 Sheets-Sheet 2

FIG-2

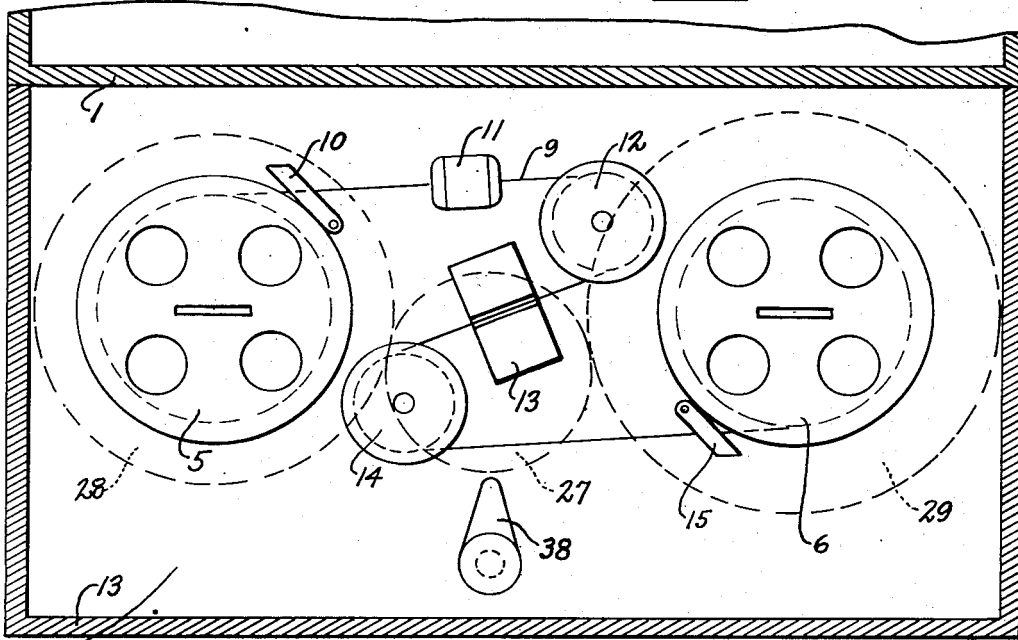
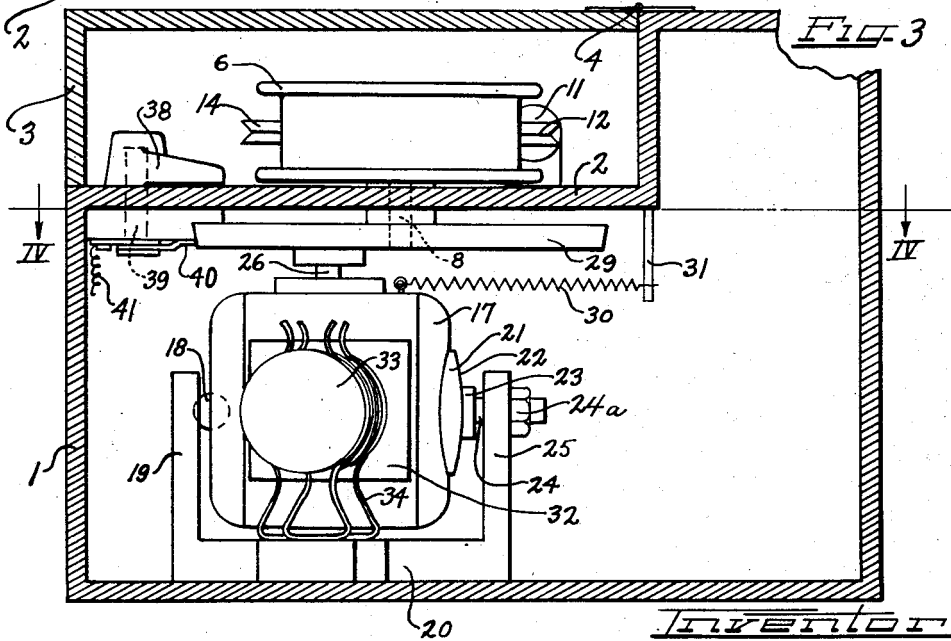

FIG-3



INVENTOR  
MARVIN CAMRAS

BY Charles W. Hills ATTORNEY

Feb. 6, 1945.

M. CAMRAS

2,369,017

MAGNETIC RECORDER AND DRIVE THEREFOR

Filed Feb. 25, 1943

3 Sheets-Sheet 3

FIG. 4

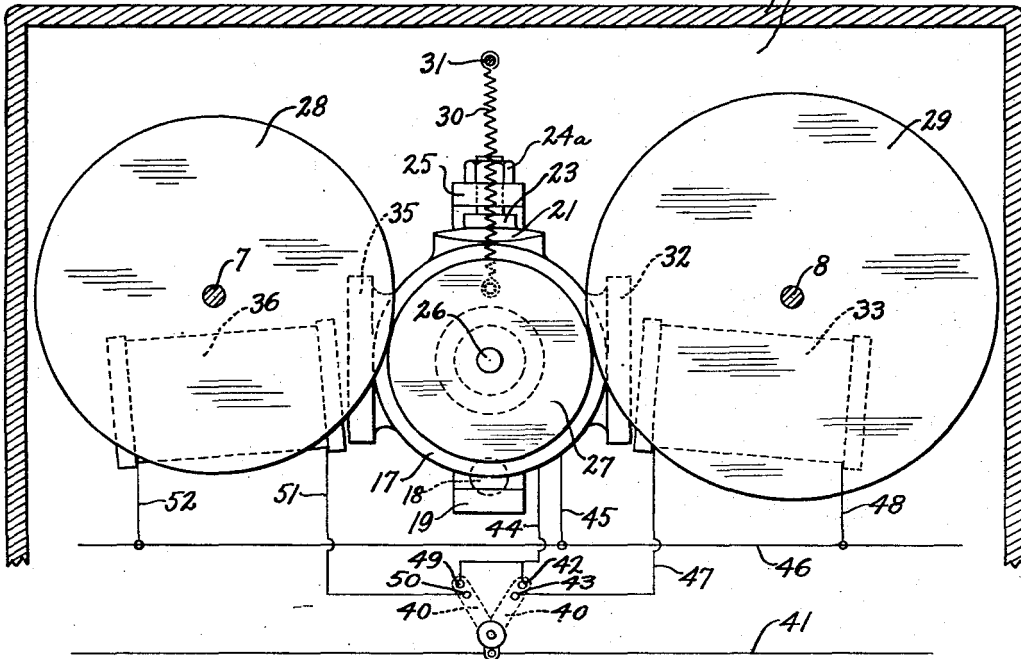
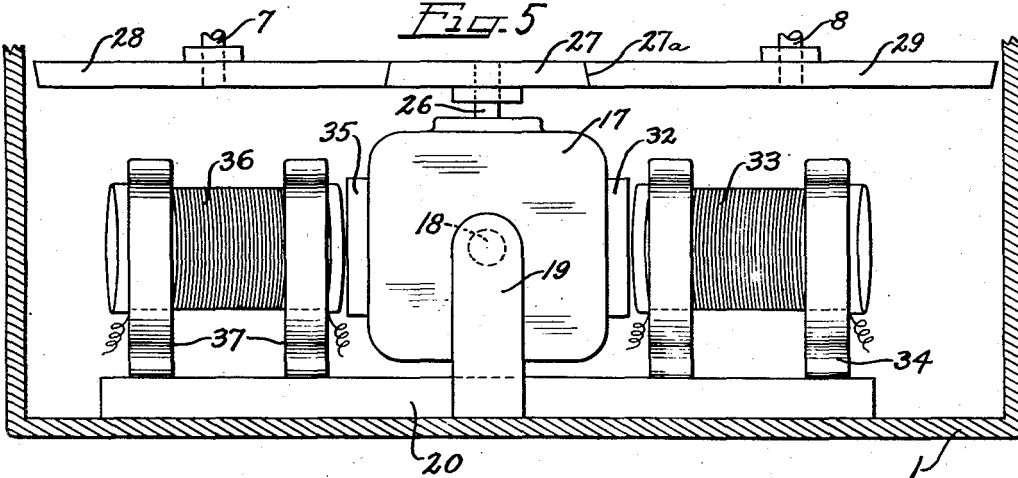

FIG. 5



INVENTOR  
MARVIN CAMRAS

BY *Charles W. Hill* ATTORNEY

# UNITED STATES PATENT OFFICE

2,369,017

## MAGNETIC RECORDER AND DRIVE THEREFOR

Marvin Camras, Chicago, Ill., assignor to Armour Research Foundation, Chicago, Ill., a corporation of Illinois

Application February 25, 1943, Serial No. 477,056

6 Claims. (Cl. 242—54)

This invention relates to improvements in a magnetic recorder and drive therefor, and more particularly to a magnetic recorder highly desirable for use in a home, office or similar location, although the invention may have other uses and purposes as will be apparent to one skilled in the art.

More specifically, the present invention is designed to be in a magnetic recording device wherein a sound recording is made by successively magnetizing increments on an elongated recording medium such as a tape or wire of paramagnetic material. Such recording may also be reproduced by the device and, if so desired, the device may be constructed to record only, or to reproduce only.

It is an object of the instant invention to provide an economical and simple form of drive mechanism for such a recording machine.

Another object of the invention resides in the provision of drive mechanism for a magnetic recording or reproducing machine, with the mechanism so arranged that there is at all times a smooth friction drive during operation.

Also an object of the invention is the provision of a magnetic recording or reproducing device embodying a drive mechanism in which the mounting of the power element is such as to give a smooth start with no jerks.

It is also a feature of the invention to provide a magnetic recording and reproducing device embodying a drive mechanism of a simplified and economical character in which the direction of drive is changed by a bodily movement of the power element, and in which the reverse drive may be faster than the forward drive.

Also a feature of the invention resides in the provision of a magnetic recording and reproducing device including a drive mechanism which not only drives the moving parts of the device, but which also automatically provides a braking action when it is desired to stop the device.

Still another object of the invention resides in the provision of a drive mechanism for a magnetic recording and reproducing device wherein bodily movement of the power element causes forward or reverse drive, and also provides a braking action when stopping or shifting from one direction to the other.

A further feature of the invention resides in the provision of a driving arrangement for a magnetic recording or reproducing device wherein the power element automatically drives the moving parts and applies a braking action to the

moving parts when it is desired to stop, by means of the same element.

Still another object of the invention resides in the provision of a drive mechanism for a magnetic recording or reproducing device, which mechanism not only drives during operation, but applies a braking action when it is desired to stop operation, and the arrangement is such that the energizing force must be off the driving element when the braking action is applied.

Another object of the invention is the provision of a drive mechanism for a magnetic recording and reproducing device wherein an electric motor is utilized as the power element, and the motor is so mounted that it will pivot in one direction for a forward drive, pivot in another direction for a reverse drive, and pivot in still another direction to effect a braking action upon cessation of operation.

While some of the more salient features, characteristics and advantages of the instant invention have been above pointed out, others will become apparent from the following disclosures, taken in conjunction with the accompanying drawings, in which:

Figure 1 is a front elevational view of a magnetic recording device embodying principles of the instant invention, showing the same with the cover in elevated or open position;

Figure 2 is an enlarged fragmentary plan sectional view of the structure of Figure 1, taken just inside the top of the casing;

Figure 3 is a fragmentary vertical sectional view of the structure taken substantially as indicated by the line III—III of Figure 1, looking in the direction of the arrows;

Figure 4 is a fragmentary plan sectional view taken substantially as indicated by the line IV—IV of Figure 3, illustrating the control switch diagrammatically and with a schematic wiring diagram added;

Figure 5 is a vertical sectional view through the forward part of the casing, illustrating the structure of Figure 4 in front elevation;

Figure 6 is a fragmentary plan sectional view taken just beneath the driving disk of Figure 5, and showing the structure of Figure 5 in plan; and

Figure 7 is a fragmentary vertical sectional view, with parts in elevation, taken through the control switch of Figure 2.

As shown on the drawings:

In the illustrated embodiment of the instant invention, there is shown a magnetic recording device including a cabinet made of wood, metal,

or any other suitable material, which is so constructed as to box in the driving mechanism as well as all of the required electrical circuits and apparatus. With reference to Figure 3, it will be seen that a platform 2 is provided in the forward portion of the cabinet, and over this platform is a door or drop closure 3 hinged to remainder of the cabinet as indicated at 4, the drop cover being shown in open position in Figure 1 and in closed position in Figure 3.

Disposed over the upper surface of the platform 2 so as to be accessible when the cover 3 is raised are a spool or reel 5 adjacent one side of the cabinet, and a similar spool or reel 6 adjacent the opposite side of the cabinet. The spool 5 is carried on a shaft 7, and the spool 6 on a shaft 8, which shaft extends through the platform 2. The spools carry a recording medium, which in the illustrated instance is in the form of a fine round wire 9, and this medium may be wound backwardly or forwardly from one spool to the other. During a recording operation, the wire travels from the spool 5 to the spool 6, and during a re-winding operation, the wire travels from the spool 6 to the spool 5. During a reproduction of a recording, the wire again travels in forward direction from the spool 5 to the spool 6.

Between the two spools certain instrumentalities are disposed in and define a path of travel for the wire. As the wire leaves the spool 5, it first passes through a level winding element 10, thence through an erasing head or demagnetizing element 11 which may be in the nature of a high frequency coil, then over a guide pulley 12, through a recording or magnetizing head 13, over another guide pulley 14, through another level winding element 15, and on to the spool 6.

In making a recording, it is not necessary to use a clean wire which may be either a completely demagnetized wire or a uniformly magnetized wire. A wire with a recording already thereon may be used, and as it passes through the erasing head 11, the wire will be demagnetized so that it will be clean before it reaches the recording head 13 in which successive small increments of the wire are magnetized in accordance with the sound production being recorded.

In operating the recorder, the wire is traveling forwardly, or from the spool 5 to the spool 6, during the making of a recording. The sound is picked up by a microphone or any other suitable pick-up device, and through a suitable amplifying and oscillating circuit the recording head 13 is energized in accordance with variations of the sound so picked up. Such electrical circuits are contained within the cabinet 1, but need not be described herein. After a recording has been made, the wire is wound in reverse direction, from the spool 6 onto the spool 5. Thereafter, the wire is again moved forwardly, the erasing head is not functioning, and the recording head then acts as a pick-up device responding to the various magnetizations on the wire, the recording head then being in circuit with a suitable loud speaker circuit so that the reproduction may be heard through a loud speaker opening 16 in the forward portion of the cabinet as seen in Figure 1. The loud speaker circuit is also contained within the cabinet but need not be described in connection with the instant invention. It will be appreciated that the spools may be changed whenever desirable, recordings preserved by removing the spool and filing it away until it is desired to be used again, or recordings may be made, reproduced, and then a new recording substituted on the same

wire for the previous recording, just as the user may desire.

The present invention centers itself more particularly with the driving means for operating the spools. It will be appreciated that the wire is usually a very fine wire, substantially the size of a human hair, approximately .004 or .005 inch in diameter being a satisfactory size for the wire. Accordingly, it is desirable to start and stop smoothly and without jerks so as not to put any undue strain upon the wire, and to prevent wastage of the wire due to over-run or coasting of the idling spool. When the wire travels forwardly, namely, from the spool 5 to the spool 6, the spool 6 will be the driven spool and the spool 5 will be idling. When the wire travels in reverse direction, the contrary is true, and the spool 5 will be driven while the spool 6 is idling. The pulleys 12 and 14 are mounted on stub shafts and idle at all times, being rotated merely by the friction of the traveling wire. The level winding elements 10 and 15 may be operated by any suitable mechanism which need not be described herein.

The driving mechanism for the reels or spools 5 and 6 is carried within the cabinet 1, and includes a power element which may be in the form of an electric motor 17. This motor is specially mounted to permit pivotal movement along an arcuate path toward each side of the cabinet from its stationary position, and also permits pivotal movement of the motor in a direction toward the rear of the cabinet when it is desired to stop operation.

With reference more particularly to Figure 3, it will be seen that the motor is mounted at the forward end on a ball 18 seated in a suitable socket in the motor casing and also in a suitable socket in a bracket 19 upstanding from a base member 20 fixed to the bottom of the cabinet. On the rear side, the motor casing is equipped with a fixed block or pillow 21 having an arcuate surface 22, the center of which is preferably at the center of the ball 18. This block 21 bears against a block 23 having an arcuate face complementary to the face 22, the block 23 being carried on the inner end of a bolt 24 extending through a bracket 25 upstanding from the base 20 and which bolt may be adjusted by a suitable nut 24a on the outside of the bracket. It is therefore apparent that the motor is in effect suspended between the ball 18 and the block 23 and is free to swing from side to side in both directions and from front to rear on the arcuate faces of the ball and the block 21.

The motor shaft 26 extends upwardly from the motor and on its upper end carries a friction drive disk 27 having an inclined driving edge 27a, as best seen in Figure 5. This drive disk 27 may engage another disk 28 carried on the lower end of the shaft 7 from the spool 5 either together with or separately from another and larger disk 29 carried on the lower end of the shaft 8 from the spool 6. If the disk 27 is in engagement with the disk 28 only, the wire is driven in the rewind direction, namely, from the spool 6 to the spool 5, the spool 5 being the driven spool and the spool 6 the idling spool. If the disk 27 engages only the disk 29, the wire is driven in forward direction, the spool 6 being the driven spool and the spool 5 being the idling spool.

If the drive disk 27 engages both the disks 28 and 29 at the same time, an automatic braking action results, thus providing a quick, even, and relatively gentle stopping of operation of the spools. It will be noted that the driven disk 29

is larger than the driven disk 28, so that the travel of the wire in a forward or recording direction is at a lower speed than the travel of the wire in reverse or re-wind direction. This obviously saves time in the re-winding operation when the wire is merely being made ready for a recording or a reproduction.

When the device is at rest and the motor is not in operation, a spring 30 attached at one end to the motor casing and at the other end to a pin 31 extending downwardly from the platform 2 pivots or swings the motor in its rearward direction so that the disk 27 simultaneously contacts both driven disks 28 and 29 to thereby apply the braking action. When it is desired to resume operation, the motor is pivoted or swung sidewise so that it contacts only the disk 28 or the disk 29, depending upon the desired direction. This sidewise movement of the motor is, of course, against the action of the spring 30 and is obtained with the aid of means now about to be described.

With reference more particularly to Figures 5 and 6, it will be seen that on one side of the motor casing a paramagnetic block 32 is mounted, which block functions as an armature for an electro-magnet 33 disposed at a slight angle to the motor and carried in one or more suitable clips 34 attached to the aforesaid base member 20. When the electro-magnet 33 is energized, the motor will swing to the dotted line position seen in Figure 6 where the paramagnetic block 32 is adjacent the end of the magnet. In this position, the driving disk 27 is in contact only with the driven disk 29 so that the mechanism will operate forwardly and the wire will travel from spool 5 to spool 6. When the magnet 33 is energized, the motor will be in rearward position by the action of the spring 30 with the disk 27 in contact with both the disk 28 and the disk 29. Upon energization of the magnet 33, the motor will move laterally along an arcuate line of travel and the disk 27 will roll over the edge of the disk 29 out of contact with the disk 28 and effect a drive of the disk 29 through a contact point further forward than is seen in Figure 4.

On the other side of the motor is a similar paramagnetic block 35, and a similarly disposed electro-magnet 36 carried in one or more clips 37. When the electro-magnet 36 is energized, the motor will swing to the full line position of Figure 6, against the action of the spring 30, the disk 27 rolling over the edge of the disk 28 out of contact with the disk 29, and a drive in the reverse direction will be effected through a point of contact between the disks 27 and 28 forward of the position seen in Figure 4.

The operation of the magnetic recording machine is controlled through a switch 38 which may be thrown either to the right or left from the neutral position seen in Figure 2. When thrown to the right, the wire 9 travels forwardly, and when the switch is thrown to the left, the wire 9 travels in the reverse or re-wind direction. With reference to Figure 7, it will be seen that the switch includes a shaft 39 which on its lower end carries a switch blade 40, one end of which is connected in any suitable fashion to a line conductor 41 emanating from any suitable source of electric current. When the switch is thrown to the right as indicated by dotted lines in Figure 4, the switch blade 40 simultaneously contacts a pair of contactors 42 and 43 which are spaced apart one from the other. The motor 17 is energized for operation by current passing from the line conductor 41 through the switch blade to

contact 42, thence through a conductor 44 into the motor windings, and returns from the motor windings through conductor 45 to the opposite line conductor 46. The electromagnet 33 is likewise energized by current passing from the line conductor 41 through the switch blade to contact 43, thence through a conductor 47 into the coil of the magnet, and returns from the coil through a conductor 48 to the opposite line conductor 46.

This operation both energizes the motor and causes it to be swung along an arcuate path to the right against the action of the spring 30 so that the driving disk 27 will contact only the larger driven disk 29 and operate the mechanism in a forward direction.

When the switch is swung to the left, as also indicated by dotted lines in Figure 4, the switch blade will engage a pair of contacts 49 and 50. The motor will be energized in the manner above described by current passing from the line conductor 41 through the switch blade and into the motor through conductor 44, returning through conductor 45 to the opposite line conductor 46. At the same time, the electro-magnet 36 will be energized by current passing from line conductor 41 through the switch blade to contact 50, and thence into the magnet through 51, returning to the opposite line wire through conductor 52. When the switch is so moved, the motor will be energized, and due to the electro-magnet 36 the motor will be swung bodily through an arcuate path to the left so that the drive disk 27 will contact the smaller driven disk 28 and operate the mechanism in the reverse or re-wind direction.

It will be noted that it is impossible to change the direction of operation from forward to reverse or reverse to forward without first passing the switch through neutral position and thus de-energizing the motor, as well as whatever electro-magnet was first energized, permitting the spring 30 to pull the motor into braking position with the disk 27 in contact with both the disks 28 and 29 and thus effecting a firm but gentle and complete stopping of operation before operation can be started in the reverse direction. This, of course, avoids any sudden jerk upon the wire or magnetizing medium 9, and prevents wastage of wire by stopping undesirable over-run or coasting of the idling spool.

From the foregoing, it is apparent that I have provided simple and economical driving mechanism for incorporation in a magnetic recording or reproducing machine, which mechanism not only is capable of driving the movable parts of the recording machine in both forward and reverse direction, but also automatically applies an effective braking action when the machine is stopped or when it is desired to shift from one direction of motion to the other. It will further be appreciated that the drive in both directions as well as the braking action are effected by the power element itself, and that the element is so arranged as to render it impossible to change direction of operation without the braking action becoming effective so that there is no undue tension placed upon the recording medium and no wastage of such medium. Further, the drive is even and smooth in character, and starts and stops may be made without jerks or similar abrupt motion.

It will, of course, be understood that various details of construction may be varied through a wide range without departing from the principles of this invention and it is, therefore, not the

purpose to limit the patent granted hereon otherwise than necessitated by the scope of the appended claims.

I claim as my invention:

1. In a magnetic recording device, a pair of rotatable spools from one to the other of which a paramagnetic recording medium may travel, a power element, a friction disk carried on the shaft of said power element, a friction disk carried on the shaft of each of said spools, and means to shift the power element bodily to cause its friction disk to simultaneously engage both the spool disks to establish a braking action upon de-energization of the power element.

2. In a magnetic recording device, a pair of rotatable spools from one to the other of which a paramagnetic recording medium may travel, a power element, a friction disk carried on the shaft of said power element, a friction disk carried on the shaft of each of said spools, means to hold said power element in such position that its friction disk contacts both said spool disks when at rest, and means to pivot said element bodily through a lateral but arcuate path to cause its disk to roll over one of the other disks out of contact with the remaining disk and drive said one disk.

3. In a magnetic recording device, a pair of rotatable spools from one to the other of which a paramagnetic recording medium may travel, a power element, a friction disk carried on the shaft of said power element, a friction disk carried on the shaft of each of said spools, means to hold said power element in such position that its friction disk contacts both said spool disks when at rest, means to pivot said element selectively in either direction and bodily through a lateral but arcuate path to cause its disk to roll over one of the other disks out of contact with the remaining disk and drive said one disk, switch means to control the movement of said power element and so arranged that a change of connection from one spool disk to the other cannot be made without de-energizing said power element and permitting the first said means to act.

4. In a magnetic recording device, a pair of rotatable spools from one to the other of which a paramagnetic recording medium may travel, a friction disk on the shaft of each of said spools,

a pivotally mounted power element, a drive disk on the shaft of said element, resilient means holding said drive element in position with the drive disk in contact with both said friction disks, a paramagnetic member on each of opposite sides of said drive element, and an electro-magnet disposed obliquely to the power element opposite each of said paramagnetic members, each such electro-magnet when energized causing said power element to swing through an arc laterally against the action of said resilient means to have the drive disk in engagement with only one of said friction disks.

5. In a magnetic recording device, a pair of rotatable spools from one to the other of which a paramagnetic recording medium may travel, a friction disk on the shaft of each of said spools, a pivotally mounted power element, a drive disk on the shaft of said element, resilient means holding said drive element in position with the drive disk in contact with both said friction disks, a paramagnetic member on each of opposite sides of said drive element, an electro-magnet disposed obliquely to the power element opposite each of said paramagnetic members, each such electro-magnet when energized causing said power element to swing through an arc laterally against the action of said resilient means to have the drive disk in engagement with only one of said friction disks, and control means for said electromagnet so arranged that only one magnet may be energized at a time and so that the power element is de-energized each time an electromagnet is de-energized.

6. In a magnetic recording device, a pair of spaced rotary reels from one to the other of which a paramagnetic recording medium may travel, a power element, a friction disc carried on the shaft of said power element, a friction disc associated with each of said reels, electrical means arranged to move said element bodily to cause it to drive either of said reels through the first said friction disc and the respective reel disc, and other means associated with said element to move it in such position that the first said friction disc simultaneously contacts both the reel discs to provide a braking action upon deenergization of said electrical means.

MARVIN CAMRAS.