

June 13, 1944.

M. CAMRAS ET AL

2,351,003

RECORDING AND REPRODUCING OF VIBRATIONS

Filed Sept. 11, 1940

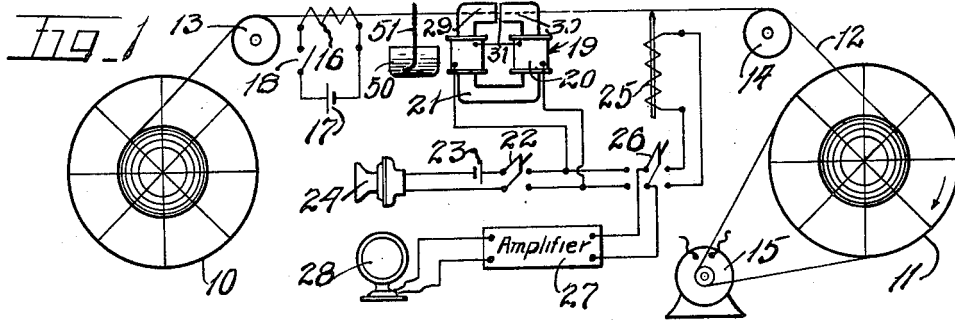

Fig. 2

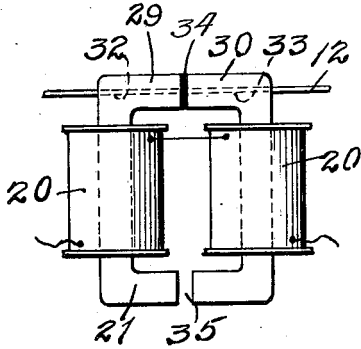

Fig. 3

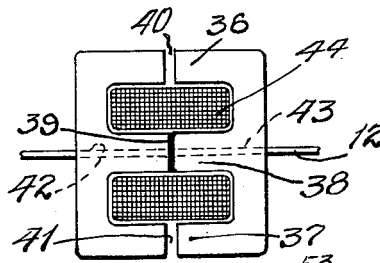

Fig. 5

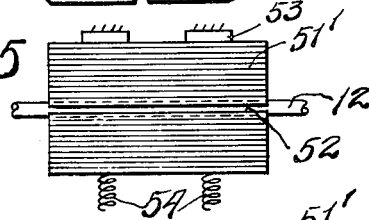

Fig. 4

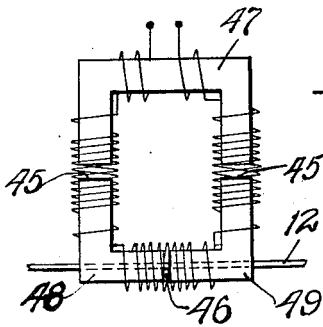

Fig. 6

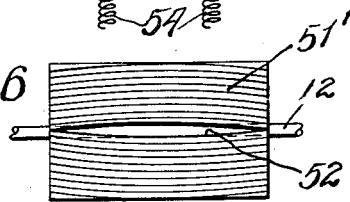
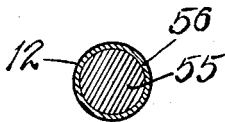

Fig. 7



INVENTORS

Marvin Camras
William Kozzon.

By *Charles D. Attys.*

UNITED STATES PATENT OFFICE

2,351,003

RECORDING AND REPRODUCING OF VIBRATIONS

Marvin Camras and William Korzon, Chicago, Ill.,
assignors to Armour Research Foundation, Chi-
cago, Ill., a corporation of Illinois

Application September 11, 1940, Serial No. 356,324

15 Claims. (Cl. 179—100.2)

The present invention relates in general to the recording and reproduction of vibrations, and is more particularly concerned with improved means and method for the recording and reproducing of sounds, signals, and the like magnetically, which may be utilized in a telegraphone or similar apparatus.

The electro-magnetic recording and reproduction of sound vibrations, speech, etc. dates back to the early work of Valdemar Poulsen in 1898, and while some improvements and refinements have been made since that time in both the method and apparatus, such improved apparatus and methods have not been utilized to any great extent commercially. There are a number of reasons for this, the most important of which are probably the inherent defects in the apparatus heretofore proposed. In general the volume level of the reproduced signals of previous systems was low, the frequency range covered was very limited, the extraneous noise was objectionable and the distortion of the wave forms was often of such character and magnitude as to render the reproduction of extremely low quality and at times almost unintelligible. The high linear velocity required for the record medium which was usually of wire, tape and the like necessitated a bulky apparatus that was exceedingly noisy, very cumbersome and inconvenient of operation, and hence unadapted generally for commercial use.

In the usual construction of such apparatus, the electro-magnet for recording and reproducing the speech, messages or signals comprised a coil wound upon a solid iron core, the pole of which was usually formed with a chisel-shaped edge that was arranged to be presented to one side if the wire, tape or other recording body. The frictional contact between this edge and the recording body resulted in rapid wear of the soft iron pole piece and frequent renewals were thus necessitated. Moreover, the use of electro-magnets of this construction had a further disadvantage in that distortions in the record occurred due to a fringing of the magnetic flux at the pole tips. This fringing tended to blur the waveform of the recorded sound, especially at high frequencies because the field would be changed before the previously magnetized portion of the record medium could be moved out of the field influence.

Although from a practical point of view the use of a wire as a record medium has a number of advantages over the use of a tape or ribbon, the latter has been more generally used in the recently developed devices. The primary objection to

the use of a wire arises from the fact that it is difficult to prevent twisting of the wire during recording and reproduction. In the usual recording arrangement, the wire is unsymmetrically magnetized circumferentially, so that any twisting of the wire relative to the reproducing pole will pass a different spot on the wire circumference under the reproducing pole than that which was passed under the recording pole, with the result that very objectionable distortions will be produced in the reproduction.

Having in mind the foregoing as well as other objections to the previous devices and methods heretofore utilized, the present invention contemplates as a primary object an improved electro-magnet construction that may be utilized with a wire arranged to pass through the magnet poles and a relatively small air gap between the pole faces, the wire in this gap being disposed at an angle to the pole faces, preferably normal thereto. With such an arrangement, the wire will be symmetrically magnetized circumferentially and by utilizing an extremely small air gap, the magnetized portions of wire in a longitudinal direction becomes extremely short, thus materially increasing the amount of recording obtainable on a predetermined length of wire and slower wire speeds.

A further object of the herein described invention is to provide an electro-magnet in which relatively large surface areas engage the record medium as it passes through the magnet poles, thus reducing the wear to a minimum.

Another object of the invention is to provide an electro-magnet for recording and reproducing vibrations, wherein fringing magnetization of the record medium is eliminated or at least reduced to such an extent as to become unobjectionable when the recorded vibration is reproduced.

Another object is to provide an improved electro-magnet for the recording and reproducing of vibrations of such construction that the recording medium as it approaches and leaves the magnet air gap will be carried through substantially field free spaces, and wherein novel means are provided for securing substantially zero magnetic potential at the points where the record medium enters and leaves the core of the electro-magnet.

Another object is to provide an electro-magnet for the herein described purpose having a novel winding and core arranged and co-related in such a manner that the magnetic field intensity of the magnetic path may be made extremely low except in the air gap where the record medium is magnetized.

Another object is to provide improved means for decreasing noise in devices of the herein described character.

Still another object is to provide novel means for preventing stray fields due to circulating and eddy currents adjacent the record medium, which would tend to set up undesirable magnetized portions in the record medium and cause distorted reproduction.

Yet another object of the invention is to provide improved means for retaining the record medium against vibration during its passage through the electro-magnet.

Still another object of the invention is to provide a record medium of improved construction

It is also an object to provide an improved method for magnetically recording vibrations on a record medium.

Other objects and features of the invention will more fully appear from the following detailed description taken in connection with the accompanying drawing which illustrates several embodiments thereof, and in which:

Figure 1 is a view schematically representing the various parts of a recording and reproducing apparatus embodying the features of the present invention, and showing the electrical connections thereof;

Figure 2 is a side elevational view of one form of an electro-magnet embodying the features of the present invention;

Figure 3 is a view partly in section of a modified construction of electro-magnet;

Figure 4 is a view diagrammatically illustrating an improved winding arrangement for electro-magnets such as embodied in the present invention;

Figures 5 and 6 are detailed views illustrating alternative constructions for the pole pieces of the electro-magnet for securing pressure contact with the record medium; and

Figure 7 is a cross-sectional view showing an improved construction for a recording medium such as may be utilized in the present invention.

As shown on the drawing:

In general, the apparatus of the present invention comprises a pair of spaced reels 10 and 11 by means of which a record medium of paramagnetic material may be moved past the recording and reproducing devices. In the present instance, the record medium is shown as comprising a wire 12 which is wound or stored on the reel 10. This wire is led over a pair of spaced guide pulleys 13 and 14 to the winding reel 11 which is arranged to be driven by any suitable power means such as an electric motor 15.

When it is desired to make a record, the record medium is first subjected to suitable means for erasing any previous history in the wire. This preparation of the wire for the reception of the record may be accomplished in a number of different ways. In the present instance, the wire is shown as being passed through the field of a direct current solenoid coil 16 which is energized by a current flowing from a suitable battery 17. The connection and disconnection of the solenoid relative to the battery may be conveniently controlled as by a switch 18 in the energizing circuit.

The record medium, thus prepared to receive the record, is then moved to a recording head or electro-magnet as generally indicated at 19.

The record medium is subjected to the magnetic influence of the recording electro-magnet in

a manner which will hereinafter be described in detail, this magnet being energized by one or more coils 20 associated with a core structure 21, the energizing coil being connectible through a switch 22 with a circuit containing an energizing battery 23 and a microphone 24 by means of which the vibrations to be recorded may be picked up and the energizing current of the electro-magnet modulated. The record medium is thus magnetized in accordance with the variation of the magnetic flux in the electro-magnet in a manner well understood in the art.

When it is desired to reproduce the vibration which has been recorded on the record medium, the record medium is then moved either to another electro-magnet similar to the recording magnet 19 or of other suitable construction, or the record medium may be again conducted through the recording magnet 19. Where a separate pickup magnet, as shown at 25 is to be utilized, the coil of the pickup magnet is connected through one throw of a double throw switch 26 with a suitable amplifier 27 which is connected with a loud speaker or other reproducing apparatus 28 in the usual manner.

When it is desired to use the recording electro-magnet 19 as the pickup for reproducing the recorded vibration or signal, the switch 22 is moved to open position, and the switch 26 is closed on its other throw, that is, closed to the left as shown in Figure 1, whereby the recording magnet 19 is connected through the amplifier to the reproducing device.

In the construction of the recording and pickup electro-magnets generally utilized in this type of apparatus, there is a tendency of the magnetic field to spread out and magnetize a larger area of the record medium than the portion in immediate contact with the pole tips. Due to this characteristic, a larger area of wire or tape is ordinarily required to register any individual cycle than would be necessary if the field were confined to an area approximating the thickness of the pole tips. A similar difficulty is also encountered during the reproducing procedure from the stray fields caused by the record itself. This condition is particularly disastrous to the higher frequencies inasmuch as each individual cycle must be registered within a very limited area thereby causing the stray fields to combine and flatten the peaks of the wave forms. The reproduction is, therefore, not sharp and natural but the sound is somewhat muffled, flat and distorted. Other distortions with the usual arrangement also result due to the fact that the electro-magnet which is utilized for recording the vibrations on the wire or tape, is so arranged that the record medium is not magnetized symmetrically in a circumferential direction. Any twisting of the record medium between the time of recording and the time of reproduction will present different portions to the pickup magnet than those which were acted upon by the recording magnet so that clear and sharp reproduction will not be produced.

In order to overcome these objections, the recording magnet core 21 is in its simplest form provided with preferably aligned polar portions 29 and 30, although they need not necessarily be aligned, having pole faces in spaced relation to define a narrow air or equivalent non-magnetic gap 31 of extremely small length. Air gaps having a length as small as 0.001 inch have been found to produce excellent results.

The polar portions 29 and 30 are provided with

bores 32 and 33 to form a passageway through the polar portions and through which the record medium is carried. While the bores are shown as being in axial alignment, the bores may be made curved, if desired. With such an arrangement, the record medium passes through the air gap 31 at an angle to the pole faces, preferably normal to or at an angle of 90° to the pole faces. In this way, the magnetic flux in the air gap is symmetrically distributed circumferentially of the record medium and magnetizes the record medium uniformly around its circumference so that any twisting which may take place in the record medium between the time that the vibrations are recorded thereon and the time when these vibrations are reproduced will in any case present similarly magnetized portions to the pick-up magnet so that the reproduction will be free of the usual distortions due to twisting of the record medium.

The air gap can easily be kept in the order of 0.001 inch or less by the use of a spacer 34 of mica or other suitable material having a central aperture to permit the passage of the record medium. This spacer prevents the entrance of foreign matter into the air gap without hindering magnetization of the record medium.

By having the record medium fit snugly in the bores where it passes through the polar portions, the length of record medium affected by the magnetic field in the air gap can be made extremely small.

In the present construction the pole pieces engage or contact the record medium over a distance that may be several times as long as the recorded wave-lengths. This is accomplished without distortion, since the record medium is maintained unaffected except when in the short air gap. In the prior art devices, the pole pieces contacted the medium over a distance which was of the same order of magnitude as an average recorded wave-length or preferably less. That is, in the older devices the attempt was always made to limit the length of contact to as short a distance as possible in order to reduce distortion, but in accomplishing this, greater wear and other undesirable defects resulted.

By thus being able to use a large surface in the polar portions in contact with the record medium, wear is reduced to a minimum. It is therefore possible to utilize a wire of small diameter, wires as small as .007 inch or less in diameter being found satisfactory. Also relatively slow speeds may therefore be utilized, and it is possible to utilize reels approximately five inches or less in diameter as compared to reels of 15 to 24 inches in diameter which were necessary for an equivalent length of recording in the prior art devices as usually constructed.

By carrying the recording medium through the polar portions before it enters the air gap and after it passes through the air gap, distortions due to the magnetic fringing effect and other undesirable magnetic flux is prevented. The record medium enters and leaves the polar portions at magnetically neutral points, and once inside of the polar portions the record medium is in a practically field free space. This is due to the fact that the magnetic potential drop in a high permeable material is small compared to that in air for the same magnetic flux.

In the construction shown in Figure 2, the core of the electro-magnet has been provided with an additional air gap 35 having a greater length and consequently greater reluctance than the main

air gap 31. By the proper adjustment of the size of the air gap 35, magnetically neutral points where the record medium enters and leaves the polar portions may be secured.

Referring to Figure 3, the electro-magnet is shown as being of a slightly different construction than that previously described. As shown in Figure 3, the electro-magnet embodies a shell type construction having outwardly disposed core legs 36 and 37, and an intermediate core leg 38. The intermediate core leg is provided with a main air gap 39 similar to the air gap 31 in the arrangement previously described, whereas the outer legs of the core are provided with the auxiliary adjustable air gaps 40 and 41, similar to the air gap 35 previously described. In this arrangement, the intermediate core leg 38 is provided with axially extending bores 42 and 43 for the passage of the record medium. The energizing coil 44 surrounds the intermediate leg.

As a further improvement, the points of entrance and exit of the record medium may be kept at the same neutral magnetic potential, and the field intensity made very low except in the main air gap by distributing the windings on the core of the electro-magnet, as shown in Figure 4, so that the ampere turns at every part of the core are in proportion to the magnetic reluctance of that part. For example, let it be assumed that a winding of one thousand turns is to be put on the core shown in Figure 4, and that the large air gaps 45—45 each have the equivalent of 30 reluctance units; the small air gap 46, 10 reluctance units; the core section 47, 20 reluctance units and the core sections 48 and 49, 5 reluctance units respectively; then the one thousand turns of the winding would be respectively distributed so as to have 300 turns for the air gaps 45—45, 100 turns for the air gap 46, 200 turns for the core section 47, and 50 turns each for the core sections 48 and 49.

Distortions due to non-linearity of the magnetizing curve of the record material provides the upper limits for the volume level which can be recorded, while the noise level determines the lower limits. By utilizing the heretofore described construction as well as constructional features hereinafter to be described, the noise level may be reduced to a minimum and recording accomplished at a lower level with consequent freedom from distortion. By approaching the air gaps through magnetically neutral points, noises due to vibration of the magnetized wire are eliminated. Noise is also reduced by the utilization of the previously described spacer in the air gap to keep out dirt and metallic dust due to wear. Noise and distortion in the recording and reproduction may be further reduced by the provision of laminated polar portions which prevent circulating and eddy currents which might set up undesirable magnetized portions in the record medium.

It has also been found that the noise may be further reduced by providing a thin lubricating film on the wire or record medium, this film forming a thin separation between the record medium and the interior surfaces of the bores of the polar portions as the record medium passes therethrough.

As shown in Figure 1, one way in which the oil film may be applied to the record medium is to provide a suitable container 50 having a wick 51 for conducting the oil or other lubricant from the container and applying it to the record medium before it reaches the recording electro-magnet.

On the other hand, instead of utilizing a wick as suggested, the record medium might be passed through an oil bath.

In Figures 5 and 6, two alternative constructions are shown for maintaining good contact between the polar portions and the record medium so as to prevent noise and vibration of the record medium while it is passing through the polar portions. In both of the constructions shown, the polar portions are constructed of laminations 51' and longitudinally split as shown at 52. One portion of the split pole piece is anchored against movement by suitable means as shown at 53 which may constitute abutment blocks, and springs 54 may be provided on the opposite side of the other polar portion, these springs and abutment blocks acting to urge the laminations of the polar portions toward the record medium.

As shown in Figure 6, another arrangement is disclosed, wherein the laminations are longitudinally curved so as to exercise a resilient clamping action against the record medium passing therethrough.

While the foregoing description has, in the main, been directed to the advantages and features of the invention in connection with the recording of vibrations, the improvements as embodied in the electro-magnet are equally desirable in the reproduction of the vibrations, although the actual operation of the parts may vary slightly during recording and reproducing.

The electro-magnet construction described herein is particularly adapted for reproducing the vibrations, and once having been properly adjusted for recording is equally well adapted to produce the most efficient distortionless reproduction.

The electro-magnet, when used as a pickup device, is most sensitive to the recorded magnetic vibrations only at the air gap through which the record medium is passed, and with a construction as shown in Figure 4, any distortions which might otherwise result from the entry and exit of the magnetized portions of the record medium is eliminated.

As a magnetized portion of the record medium is brought into or leaves the magnet core any flux set up in the core will tend to pass through the winding coils in such direction as to induce opposed voltages which cancel out and become ineffective so far as they might distort the reproduction. As soon as a magnetized portion of the record medium is disposed within a polar portion, the adjacent material of the polar portion effects a local magnetic circuit which will be ineffective to induce voltages in the coils of the winding. However, when the magnetized portion of the record medium reaches the air gap, the magnetic circuit carrying the magnetic flux will be such that the induced voltages in the winding coils will be additive and most effective in reproducing the recorded vibration. Likewise, similar effects take place in reverse order as the magnetized portions leave the core.

In general, it has been customary with devices of this type to utilize a record medium of homogeneous construction. Such record medium when in the form of wire or tape very often will contain variable magnetizing properties which may considerably affect the uniformity of the recording and reproduction of the vibrations. In our improved construction, the record medium contains a core portion which may be of phos-

phor bronze or other strong non-magnetic material 55 or a suitable material of low magnetic retentivity which has a thin covering or coating 56 of magnetic alloy or other suitable material of relatively high magnetic retentivity deposited on its outer surface. Such a construction permits of more accurate control of the magnetic characteristics of the record medium during its construction than is possible in the construction of the ordinary wire and tape as now used. Our improved construction enables the vibrations to be more sharply and accurately recorded and reproduced.

It is to be clearly understood that while we have primarily described the present invention in connection with the recording of vibrations, it is not to be so limited since the invention may with equal facility be utilized for the reproducing of vibrations from the record medium.

It is thought that our improved method will be understood from the description of the apparatus, and that further description of the method will be unnecessary.

While we have illustrated and described several forms of construction, we do not wish to limit ourselves to the precise details of the structures shown, but desire to avail ourselves of such variations and modifications as may come within the scope and spirit of the appended claims.

We claim as our invention:

1. In a device of the character described, an electro-magnet having a metallic core portion defining a pair of polar portions with confronting closely-spaced pole faces and forming a non-magnetic gap therebetween, a passageway extending through the polar portions and opening into the space between said pole faces, and a record medium movable lengthwise through said passage and passing through said space, said polar portions being positioned with respect to said electro-magnet in such a manner that said electro-magnet surrounds said non-magnetic gap, whereby the M. M. F. drop in the magnet circuit is substantially entirely across said non-magnetic gap, and whereby adjacent portions of said polar portions are free of any M. M. F. drop.

2. In a device of the character described, an electro-magnet having a pair of laminated polar portions with pole faces in spaced relation to form a non-magnetic gap, and a record medium passing through the polar portions and said gap at an angle to the pole faces, said laminations being bowed to retain them in pressure engagement with the portions of the record medium in the polar portions.

3. In a device of the character described, an electro-magnet having a pair of laminated polar portions with pole faces in spaced relation to form a non-magnetic gap, a record medium passing through the polar portions and said gap at an angle to the pole faces, and means for resiliently urging the laminations in the polar portions toward the record medium passing there-through.

4. In a device of the character described, an electro-magnet having a pair of split polar portions with pole faces in spaced relation to form a non-magnetic gap, a record medium passing through the pole portions and said gap at an angle to the pole faces, and means resiliently urging the parts of each split polar portion toward the record medium passing therethrough.

5. In a device of the character described, an electro-magnet having a pair of elongate polar

portions with pole faces in spaced relation to form a non-magnetic gap, a record medium passing through the polar portions and the non-magnetic gap, and a disk of non-magnetic material closing said gap, said disk having an opening therein for the passage of the record medium.

6. In a device of the character described, a split magnetic core having polar end portions defining a non-magnetic gap, a record medium entering and leaving the non-magnetic gap through the polar portions, and a coil forming a source of M. M. F. operatively associated with said core and completely surrounding said non-magnetic gap.

7. In a device of the character described, a magnetic core having polar end portions defining a plurality of non-magnetic gaps, a record medium entering and leaving one of said gaps through its associated polar portions, the other of said gaps being so adjusted as to effect substantially magnetic neutral areas in the polar portions at the points where the record medium enters and leaves, and a coil operatively associated with said core.

8. In a device of the character described, a magnetic circuit including a magnetic core having polar end portions defining a non-magnetic gap in the magnetic circuit, a record medium movable relative to said non-magnetic gap, and a distributed winding for said magnetic circuit surrounding said non-magnetic gap, the ampere turns of said winding for the respective parts of the magnetic circuit being substantially proportioned according to the respective reluctances of said parts.

9. In a device of the character described, a magnetic circuit including a core having polar end portions defining a plurality of non-magnetic gaps in the magnetic circuit, a record medium entering and leaving one of said non-magnetic gaps through its associated polar portions, and a plurality of windings for said magnetic circuit each of said non-magnetic gaps having one of said windings surrounding the same and each of said windings having its ampere turns distributed approximately according to the reluctance of the particular part of the magnetic circuit associated therewith, whereby the only appreciable M. M. F. drops in said magnetic circuit are across said non-magnetic gaps.

10. In a device of the character described, a magnetic core having a pair of outer legs and an intermediate leg, non-magnetic gaps in each of said legs, a winding surrounding the intermediate leg, a passageway extending through the intermediate leg, and a record medium longitudinally movable through said passageway and the non-magnetic gap of the intermediate leg.

11. In a device of the character described, a magnetic core including a pair of legs interconnected at each set of their ends by a magnetic path including a non-magnetic gap, a record medium movable through one of said gaps at an an-

gle to its transverse plane, and a winding distributed on the legs of said core and surrounding each of said non-magnetic gaps.

12. In a device of the character described, a magnetic yoke member having a plurality of non-magnetic gaps therein formed by confronting faces of polar portions of said member, an electric solenoid forming a source of M. M. F. surrounding and extending completely over each of said non-magnetic gaps, said solenoids being electrically connected in series, a record medium entering and leaving one of said non-magnetic gaps through its associated polar portions, whereby the M. M. F. drops in said yoke member outside of said non-magnetic gaps are substantially zero, said plurality of non-magnetic gaps in said yoke member providing a flux density, magnetic potential characteristic curve approximating a linear function.

13. In a magnetic recorder and reproducer, a U-shape electromagnet having a pair of magnetic polar portions with pole faces in closely spaced confronting relationship, said polar portions each having a passageway extending longitudinally therethrough along the same general line as the magnetic axis of said polar portions, said passageways being aligned with respect to each other, a record medium extending through said passageways, the wall portions of said polar portions which form said passageways extending at least partially around said record medium when viewed in a transverse sectional plane, said passageways being many times longer than the distance between said confronting pole faces.

14. In an electromagnetic recorder and reproducer, a U-shape electromagnet having a pair of magnetic polar portions with pole faces in closely spaced confronting relationship, said polar portions each having a passageway extending longitudinally therethrough along the same general line as the magnetic axis of said polar portions, said polar portions and said passageways being aligned with respect to each other, a record medium extending through said passageways, the wall portions of said polar portions which form said passageways extending at least partially around said record medium and in close contact therewith when viewed in a transverse sectional plane, said polar portions being substantially in engagement with said record medium along a relatively long portion thereof as measured along the longitudinal axis of the record medium and as compared with the wave length of the recorded vibrations.

15. In a magnetic recorder head, a paramagnetic core shaped to provide confronting pole pieces with a non-magnetic gap therebetween, said pole pieces being shaped to provide a path for a traveling recording medium, and a coil surrounding said pole pieces and said path over said non-magnetic gap.

MARVIN CAMRAS.
WILLIAM KORZON.