

Objectives:

- Investigate microphones that most accurately capture customers' voices in outdoor environment.
 - Investigate various microphone polar patterns, namely, omnidirectional, cardioid, and super-cardioid.
- Implement a pre-amplifier for the selected microphone.
- Determine the scale of speaker that is placed in the kiosk to provide reasonable sound volume and range.
- Design a kiosk based on the existing ones for the prototype of the drive-thru system.
- Evaluate the audio quality of the developed system.
- Develop a prototype of improved sound quality drive-thru system.

How Class D Amplifiers Operate:

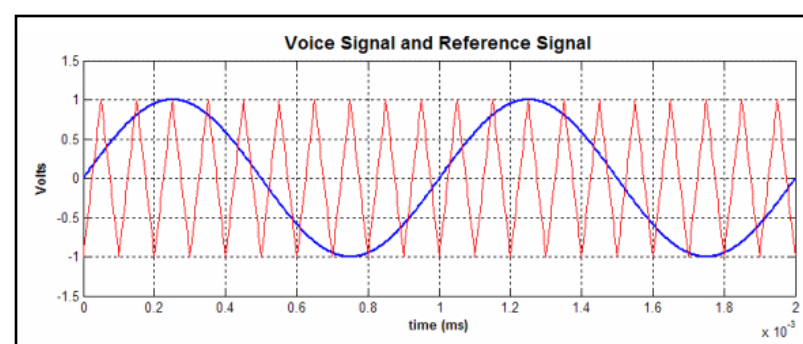

The output of the comparator is a square wave that corresponds to the difference between the two signals. For any given instant in time when the input signal is greater than the reference signal the comparator outputs a logical one. Conversely, when the reference signal is greater than the input signal the comparator outputs a logical zero.

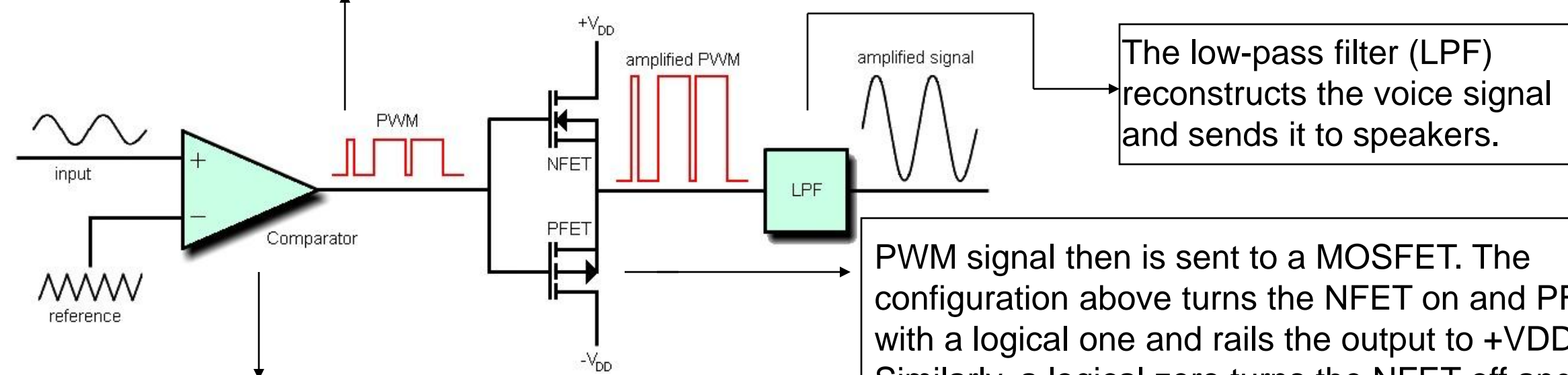

The low-pass filter (LPF) reconstructs the voice signal and sends it to speakers.

PWM signal then is sent to a MOSFET. The configuration above turns the NFET on and PFET off with a logical one and rails the output to +VDD. Similarly, a logical zero turns the NFET off and PFET on and rails the output to -VDD. That results in an amplified PWM signal.

Why they are efficient:

- We can examine the power usage using $P=IV$
- When a MOSFET is on, voltage from drain to source is about zero
 - This means zero power usage
- When a MOSFET is off, the current from drain to source is zero.
 - Again means zero power usage
- The only time a Class D amp draws power is in the transition between low and high in the PWM signal
- Can be 90-95% efficient.

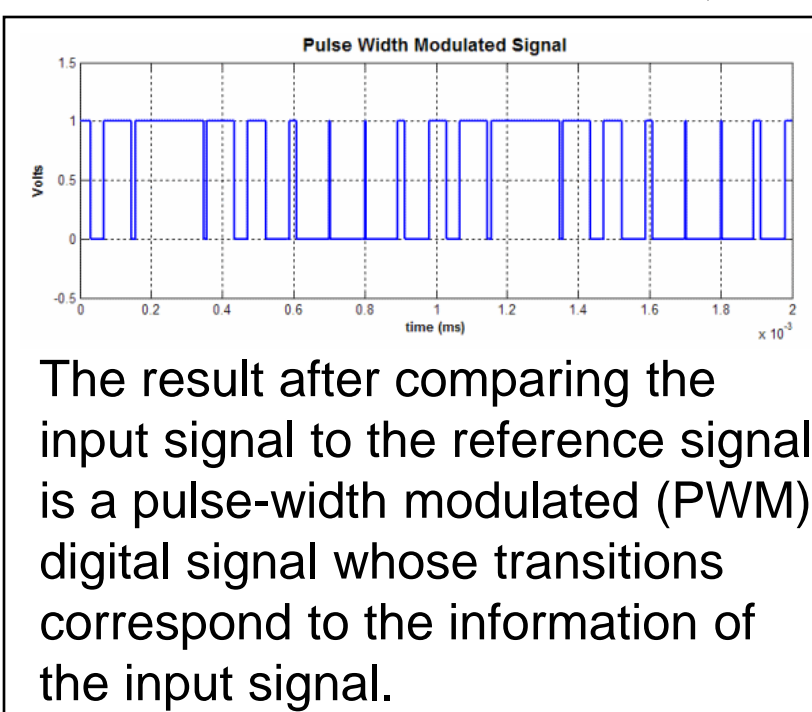

The result after comparing the input signal to the reference signal is a pulse-width modulated (PWM) digital signal whose transitions correspond to the information of the input signal.

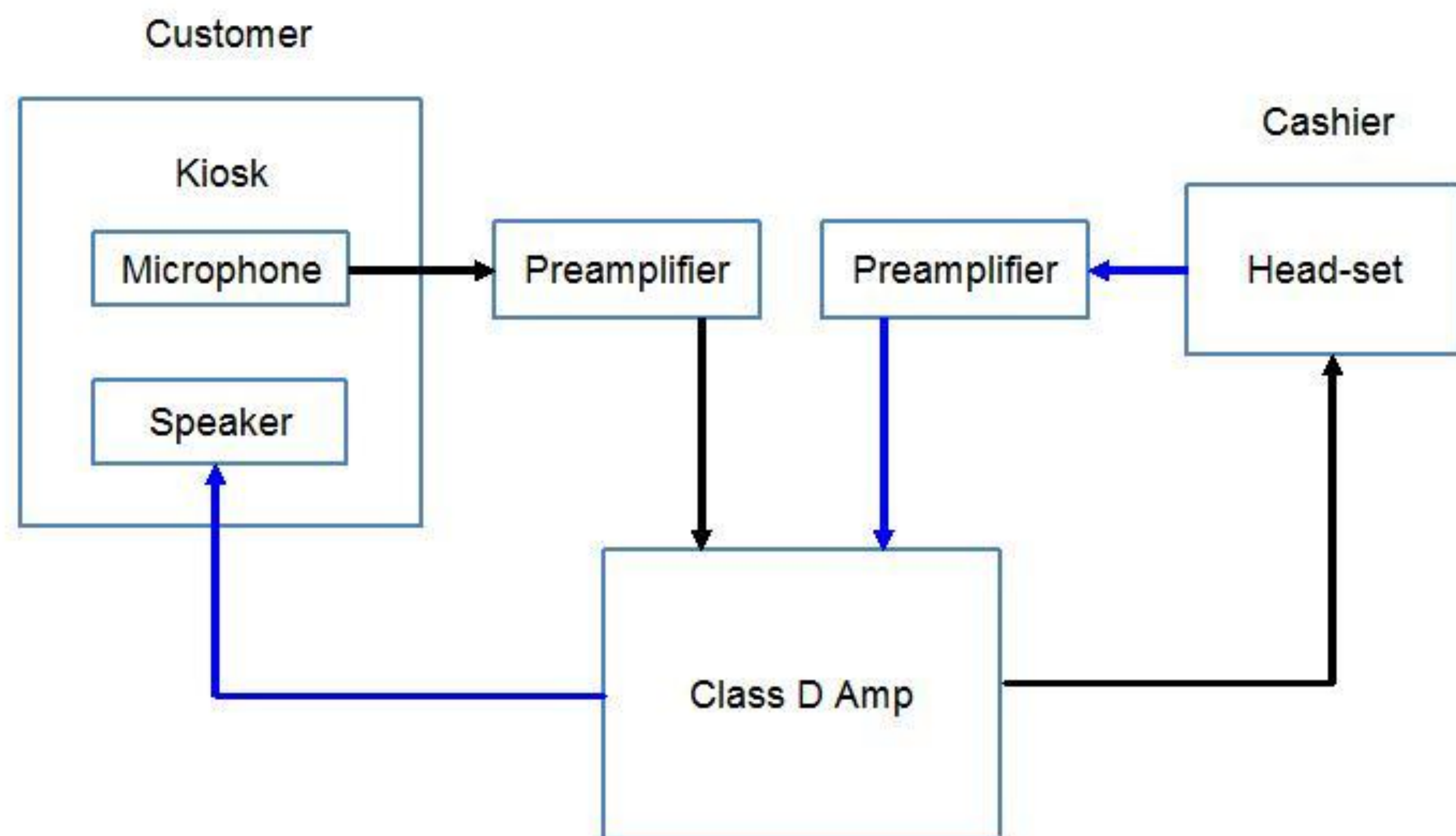

Pre-Amplifier:

Consists of three major sections:

1. Power Supply Management
 - Astrodyne ASL 40-48 open frame power supply provides 48V through a 315mA fuse.
2. Operational Amplifier Configuration
 - Operational amplifier configuration:
 - The difference amplifier uses 1/2 of a LM833 amplifier. The LM833 was chosen for its low noise and large band width performance characteristics
3. Pre-amp input protection
 - The Op amp input protection serves to separate the circuit from the 48V DC phantom power and any associated transients, as well as any possible overloading input signals.

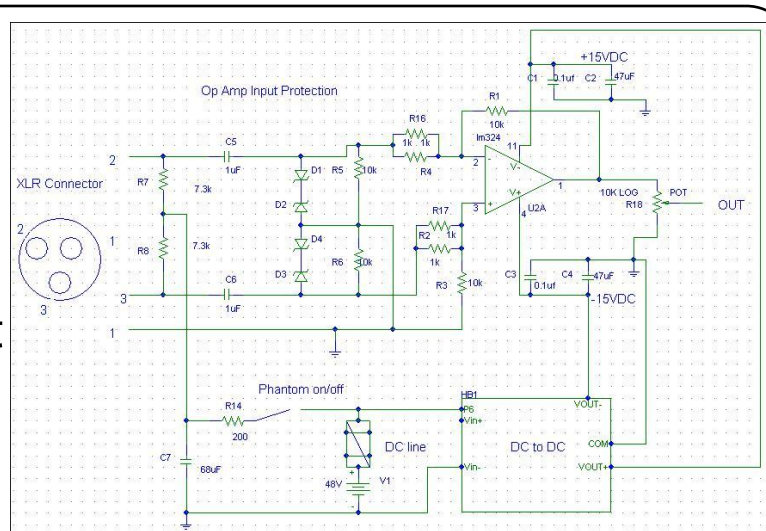

Microphone:

- MX-100 series from Shure Inc.
- Produces a balanced signal
- High Quality Microphone Assembly
 - Built-in preamp with 12 dB gain
 - Reduces the impact of any electromagnetic interference on the cable
 - A higher quality element with a relatively flat frequency response from 20hz to 20kHz



Kiosk:

- Isolates the interior of the kiosk in order to prevent sound feed back from speaker to microphone.
- Mimics an actual drive through kiosk.
- Shock absorbing microphone mount to reduce low frequency vibrations.
- Sound absorbing foam in microphone compartment.

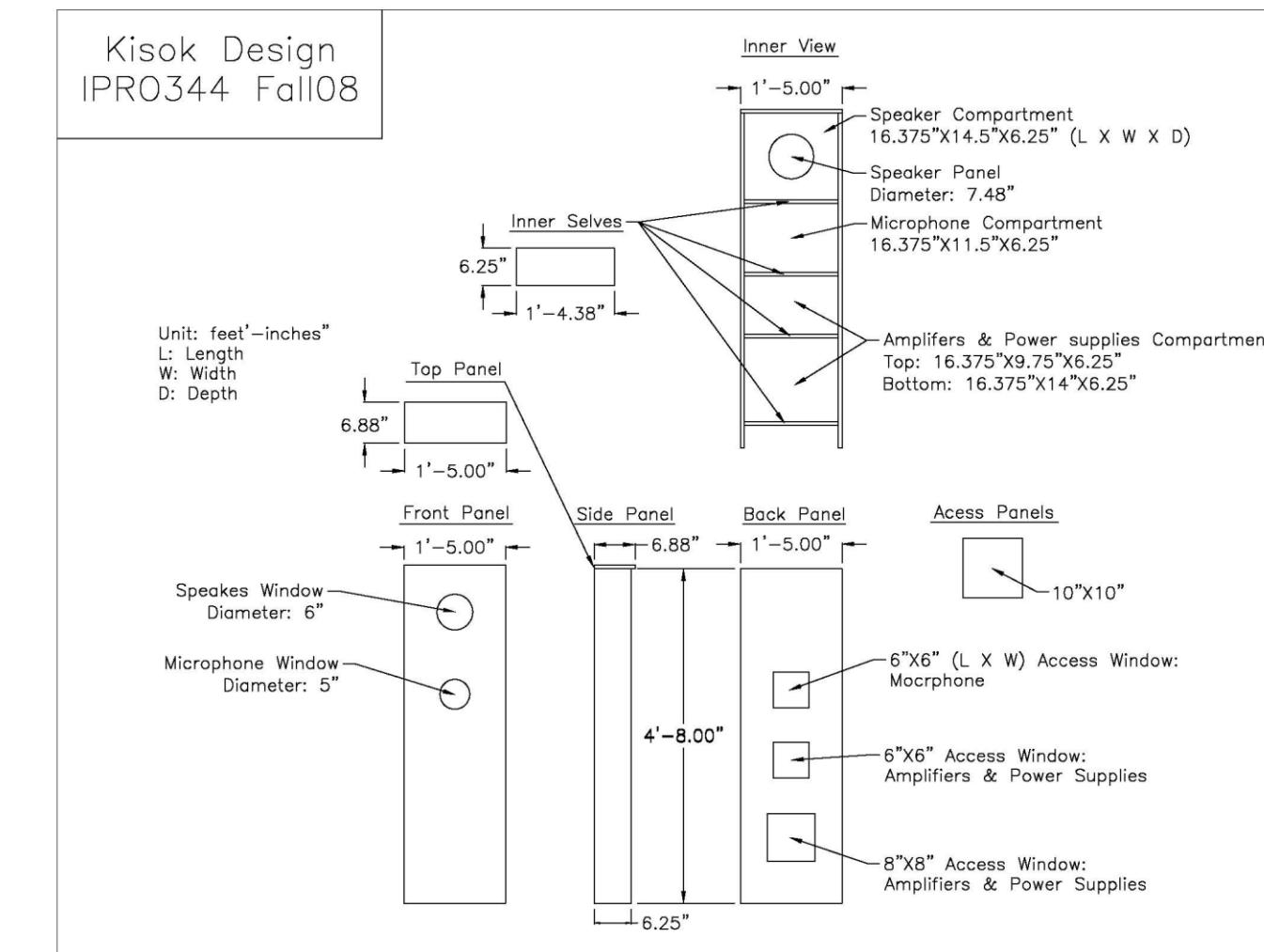
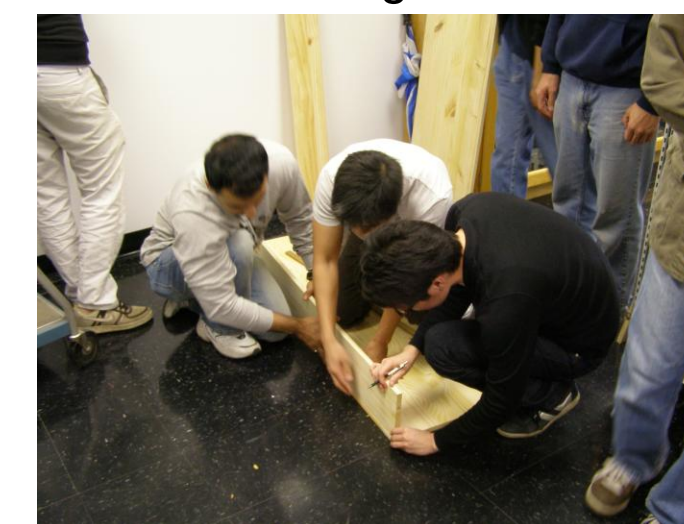

Tests and Results

Test	[MME] HTO CLARO	Speaker Preamp	Mic Preamp
Frequency response dB:	+0.01, -0.12	+0.05, -0.72	+2.81, -14.80
Noise level, dB:	-98.5	-94.1	-85.1
Dynamic range, dB:	98.6	93.9	85.2
THD, %:	0.0034	0.0043	0.0041
IMD + Noise, %:	0.0073	0.078	0.030
Stereo crosstalk, dB:	-51.0	-43.4	-49.4

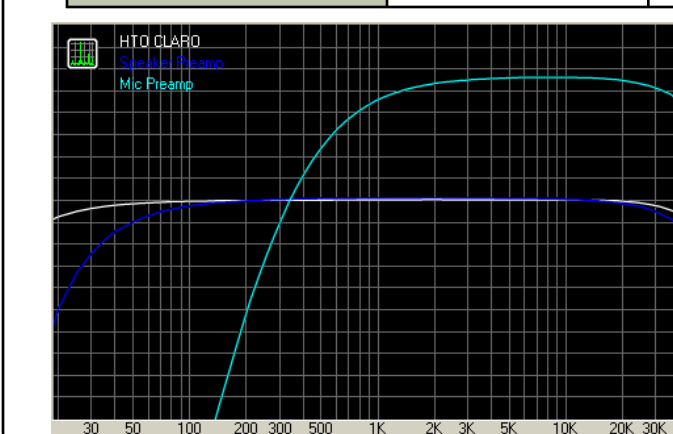

Figure 1 Frequency Response

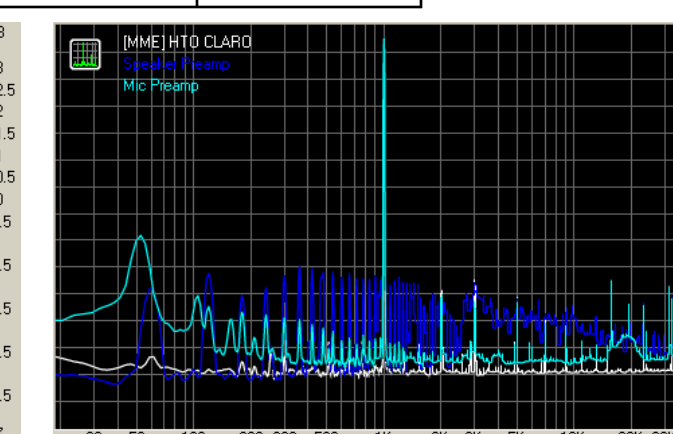

Figure 2 THD + Noise

RightMark Audio Analyzer Feedback Loop test:

- Line Out --> Preamp-Under-Test --> Attenuator--> Line In
- RMAA was run in mono-mode (preamps use only one channel)
- 24 bit/96 kHz sampling rate.
- The output of Preamp was connected to an attenuator box with the settings -26 dB attenuation for the 26 dB gain preamp.

Results:

- Frequency Response matches the Pspice simulation.
- For Total Harmonic Distortion, Intermodulation distortion, and Noise level, the mic-preamp has better results than the speaker preamp

Future Goals:

- Test the system we built this semester. Do this with one speaker outputting a signal, and a second one outputting noise, and then measure the signal to noise ratio for various speaker placements.
- Find a material to cover the kiosk and make it look and sound more realistic. This should include a curved top
- Use terminals on the back side of the kiosk for power connections, speaker connections, and headset microphone. This way, there is no hole on the back side of kiosk with wires sticking out and everything internal can be hardwired to the terminals
- All circuits should be fused. Any circuit that will continue to be used in Spring 2009 needs to have a fuse for protection.
- Consider an AGC (automatic gain control) circuit for the microphone. This should make the incoming voices relatively equal, regardless of customer's volume. At the minimum, make the microphone preamplifier variable gain.
- Collaborate closely with IPRO 343 to accurately simulate a drive-through experience
- Conduct quantitative studies and develop metrics for an acceptable drive-thru intercom system. Qualitative human studies should no longer be considered.