

IPRO 339

# Piston and Piston Pin Manufacturing Process Improvement

---

Project Sponsor: **Burgess-Norton Manufacturing Company**

Advisor: **Philip Lewis**

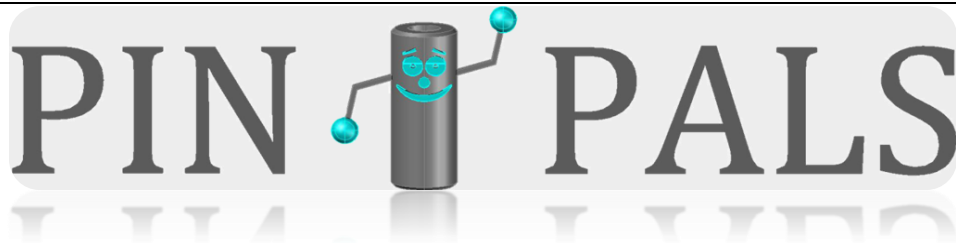

Assyl Akhambay

Yun Seon Heo

Sandrine Simen

Edilberto Barrera

Terrance King

Collin Perle

Dylan Binder

Hyunseok Ko

Guy Truong

Wahib Douh

Andrey Kolesnikov

Krystian Ustupski

## Table of Contents

1	Executive Summary .....	1
2	Purpose and Objectives .....	2
3	Organization and Approach .....	3
4	Analysis and Findings.....	5
4.1	Previous solutions .....	5
4.1.1	Pick and place system .....	5
4.1.2	Conveyor belt.....	6
4.1.3	Ammo box .....	7
4.1.4	Spring box.....	8
4.2	Final solution.....	9
4.2.1	Pin pusher system .....	9
5	Conclusions and Recommendations .....	10
6	Appendix.....	13
6.1	Impact Energy Test Results.....	13
6.2	Hardness Test Results .....	13
6.3	Roster .....	14
6.4	Budget .....	14

## 1 Executive Summary

The purpose of this report is to outline the preliminary design of a new manufacturing loading system for the Burgess-Norton Manufacturing Company (BURGESS-NORTON) plant in Geneva, Illinois. The primary reason for this is due to the fact that in the current process, a number of piston pins become nicked and damaged and therefore are rendered useless for retail. Over the course of the Spring 2011 semester, the Illinois Institute of Technology's IPRO 339 team worked towards developing an eloquent solution on effectively eliminating nicking of the piston pins that has been a persisting problem of the Burgess-Norton Manufacturing Company for many years. In detail, our team made efforts on providing Burgess-Norton with an effective solution, while increasing productivity, and decreasing the cost per unit, all while assuring high quality control and assurance. Due to the nature of this unique manufacturing challenge, the plant's loading system design was focused on by the IPRO team this semester. Included within this report are the methods, results, and a general discussion of the selected solution; in addition to the final recommendations for next semester's IPRO team whose goal will be to study and design an efficient piston pin unloading system.

## 2 Purpose and Objectives

The sponsor of this IPRO project, Burgess-Norton Manufacturing Company, is the world's largest manufacturer of piston pins and leading producer of powder metal parts. Burgess-Norton operates six facilities around the world, including one in Geneva, IL. One of Burgess-Norton's specializations is the development and manufacturing of piston pins. Over the years, Burgess-Norton has encountered some problems in their manufacturing process. Their main recurring problem is the existence of nicks on the chamfered ends of the smaller sized piston pins. This is due to the fact of the change in dimensions of the chamfered ends. As piston pins became smaller in the early 1990's, nicks began appearing regularly during the handling and transportation phase of the manufacturing process. In order to remedy this problem, Burgess-Norton added personnel to handle and inspect the pins. While this brought the nick occurrence down, the cost of manual labor increased in an inefficient manner. At this point, any number of nicks is unacceptable for Burgess-Norton.

For years Burgess-Norton has been searching for an effective solution to this problem that would bring costs down. Thus far, their engineering and research teams have been unsuccessful. As a result, they have outsourced to IIT in order to find fresh, creative ideas that would differ from Burgess-Norton's thought process.

The main objective of this IPRO is to come up with a way to automate the transportation of piston pins from one machine to another in a manner that will reduce nicking of the pins. Currently, pins travel from the chamfer machine onto a conveyor and into a person's hand. Pins are then manually placed in metal trays and transported to the heat treatment process. The idea is to come up with a solution that will eliminate the manual handling of pins while also reducing nicks. At this stage in our project, no current well known technologies or products exist for the prevention of nicks on piston pins. Therefore, it is necessary to come up with original solutions to this issue.

Doing so will improve the production rate for Burgess-Norton and as a result, increase customer satisfaction. Reducing the cost of production, will allow Burgess-Norton to focus on different areas, allocate funds and redirect their energy into new areas of their business.

### 3 Organization and Approach

Pin Pals project team was flexibly divided into several sub-groups, to efficiently solve the problem and to narrow the scope of work for each member. Due to our requirement in reducing nicks in the piston pins manufactured by Burgess-Norton and the other reduction in manual labor associated with material handling, our IPRO team focused on nick reduction and automation in the handling and manufacturing processes. The sub-teams were organized as seen in Table 1.

**Table 1: Initial Project Sub-Teams**

Team Leader: Collin Perle			
Data analysis	Testing	Process Improvement	
Dylan Binder (leader) Sandrine Simen	Guy Truong (leader) Yun Seon Heo Hyunseok Ko	A	B
		Wahib Douh (leader)	Andrey Kolesnikov (leader)
		Edilberto Barrera Krystian Ustupski	Terrance King Assyl Akhambay

The data analysis sub-team was in charge of sorting through and analyzing the data received from Burgess-Norton and then reporting their findings to the rest of the team. They identified areas in Burgess-Norton’s manufacturing process where nicks were most likely occurring allowing the other sub-teams to focus their investigation.

The testing sub-team initially tried to find out where and why the nicks occur. They performed experiments to determine the limits a pin could handle before a nick was incurred and also determined the area of the pin most susceptible to damage. Test samples were received from BURGESS-NORTON and represented the pins at various points throughout the manufacture process. The samples were tested to determine the minimum impact energy a pin could achieve before nicking occurs and the resulting data was fed back to the design teams. The results of the impact test and the hardness test can be found in Appendix A and Appendix B, respectively.

The process improvement team started with observing the operations that they were dealing with and established possible sources for appearance of nicks or possible ways in automation of material handling. By coordinating with data analysis and testing group, the process improvement teams could ensure that the sources that were being considered actually do have potential to increase defect ratios in the production process at Burgess-Norton.

After thorough observation and research, the teams defined plausible causes for nick appearance at Burgess-Norton’s present production line. Later, the team divided into further sub-teams as shown in Table 2, in order to focus on possible solutions. Each group developed their idea that will not only reduce or eliminate risk of defect but also minimize human power without hindering production capabilities.

**Table 2: Secondary Project Sub-Teams**

Chute	Spring Box	Ammo Box	Conveyor	Pick and Place
Edilberto Barrera Krystian Ustupski	Terrance King Sandrine Simen	Dylan Binder Andrey Kolesnikov	Wahib Douh Hyunseok Ko	Yun Seon Heo Collin Perle

Communication with Burgess-Norton provided the team apparent guidelines to advance in the project. Due to the limitation in funding and the condition of their facilities, our group reset our goal to design simple and applicable system. Accordingly, Pick and Place and Pusher system became most feasible candidates. In order to confirm our finalized design, the whole group had been discussing about evaluation and improvement that might be possible of each design.

**Table 3: Tertiary Project Sub-Teams**

System Design	Component Investigation				
Terrance King Collin Perle	Pan Conveyors	Pan Rotating & holding system	Pan holding system	Pin Pusher	Sensors
	Hyunseok Ko Assyl Akhambay	Edilberto Barrera Guy Truong	Wahib Douh Andrey Kolesnikov	Krystian Ustupski Collin Perle	Yun Seon Heo Sandrine Simen

As soon as the final system decided, the team divided again into sub-groups (Table 3) to research the components the proposed solution would make use of in order to determine approximate cost and also to facilitate the final selection of parts.

## 4 Analysis and Findings

Testing of the pins was conducted to determine the minimum energy required to put a nick on a pin. It was determined through experimentation that a drop of three inches will produce a nick when two pins strike. We have used this throughout our analysis of potential solutions to decrease the risk of product defects due to our pin handling solution and the results can be viewed in Appendix 1 and Appendix 2.

### 4.1 Previous Solutions

#### 4.1.1 Pick and Place System

One system that was analyzed for effectiveness and feasibility was a pick and place system. This solution made use of a robot which would pick up each pin individually and gently place it in a tray. It maintains orientation of the pins to assist in the preceding of the manufacturing process. However, the cost of the system is quite prohibitive, especially when multiple are required. The cost estimate was determined to be approximately \$30,000 per unit. While this was and still is a potential solution, it is not the best solution. There are many aspects of this system which have assisted in our design of the right solution.

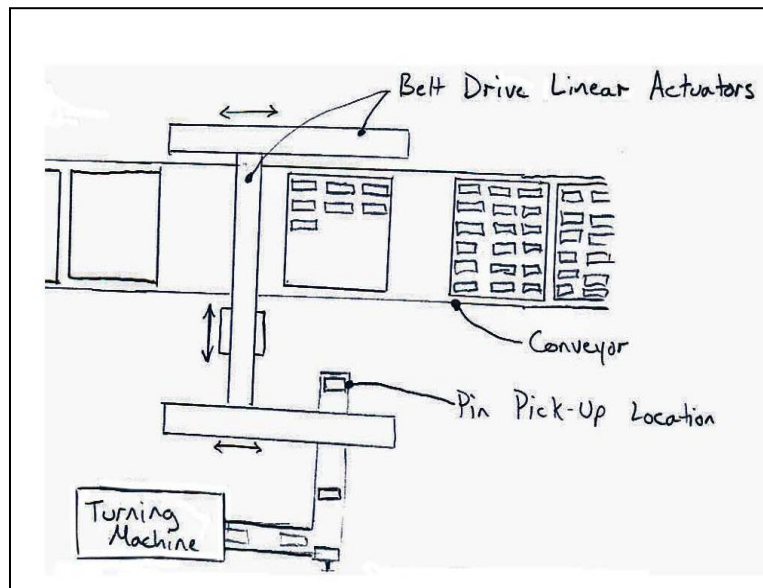

**Figure 1: Pick and Place System**

### 4.1.2 Conveyor Belt System

Another proposed system was a V constructed conveyor belt. This was proposed due to the efficiency and lean operation it provides. It entails two conveyor belts running parallel to each other -from the piston pin machining sector of the plant- on a V shape to the next manufacturing process which is heat treat. The main advantage of this system was automation without human interaction until the next step in manufacturing. The disadvantage we faced was the proper accommodation of multiple lines which is hard since there is more than one machine outputting pins. Moreover, the manufacturing plant makes many other parts and it was deemed to much of a logistical challenge to feed pins directly to the heat treat furnaces and still have all the other processes operate efficiently.

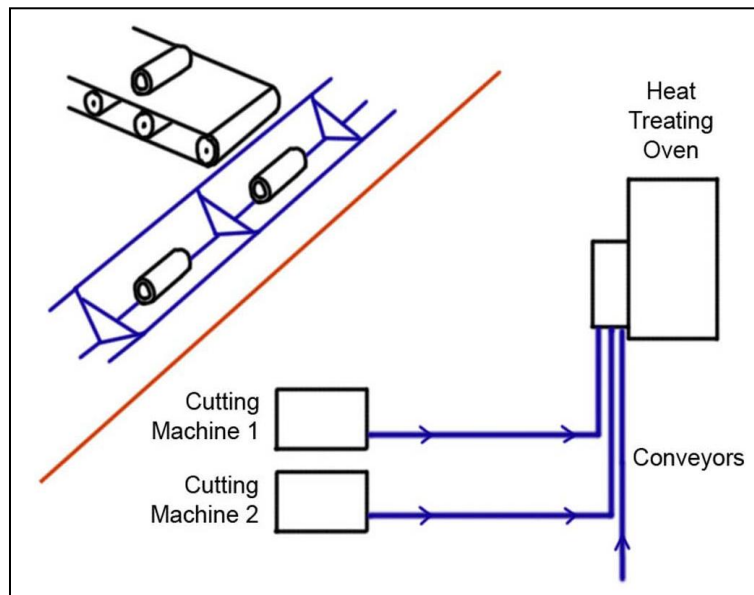

Figure 2: V-Belt Conveyor System



### 4.1.3 Ammo Box System

Another solution was to utilize a special box to semi-automatically stack the pins in a similar fashion as done in ammo boxes. This device was intended to be loaded via a small opening at one of its corners, rolling all the pins into the box one-by-one and maintaining consistent loading by pivoting the box around the opening. This design would automatic filling of the box and alignment of pins inside. Additionally, the ammo-box design allowed for semi-automated unloading by flipping the box to position the opening on the bottom, allowing pins to fall out one-by-one and be fed into the next operation by conveyor.

The obstacles that this solution faced was the need for changing all new boxes, and the limitations of pin sizes that would fit into particular box size. It was later determined that a similar concept was already utilized by the factory for one particular customer that provided such boxes - they use same concept for loading and unloading of boxes as we have proposed for our ammo-box design.

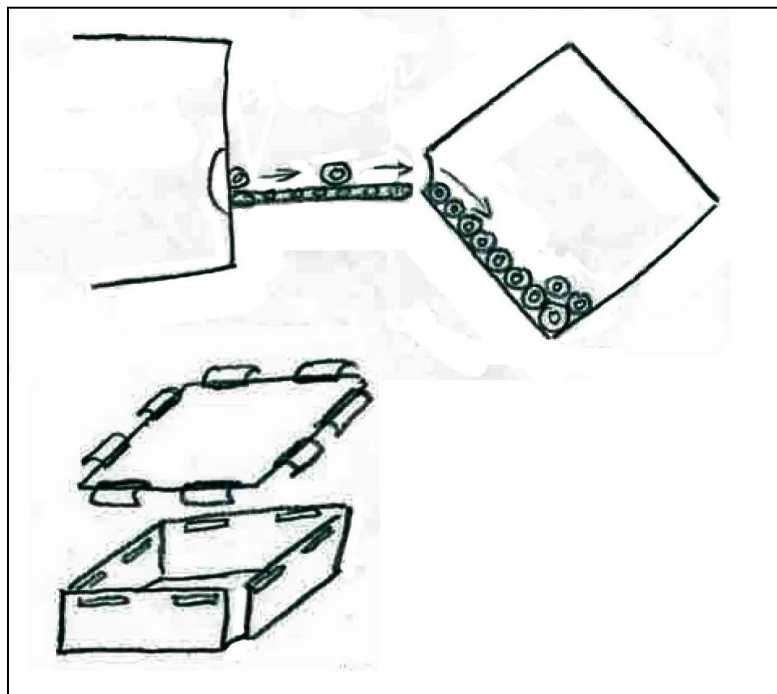

Figure 3: Ammo Box System

#### 4.1.4 Spring Box System

A final passive solution was investigated, which was dubbed the Spring Box. This box was an automatically lowering container that would reduce in height as it became filled with pins. The decrease in height was designed to lower proportionately with the amount of pins inside. This allowed the pins to fall into it at the three inch drop height and would maintain that height as the bin continued to fill. This system had another advantage in that workers who unloaded it would have an easier time pulling the pins out since it would raise to a good working level as pins were pulled out; they would never have to reach all the way to the bottom since the bottom would come to them. This design, while a great idea, was not what Burgess-Norton was looking for and thus was scrapped. It did not meet their requirement of maintaining orientation of the pins to facilitate automation in the future and consequently time was spent investigating other ideas.

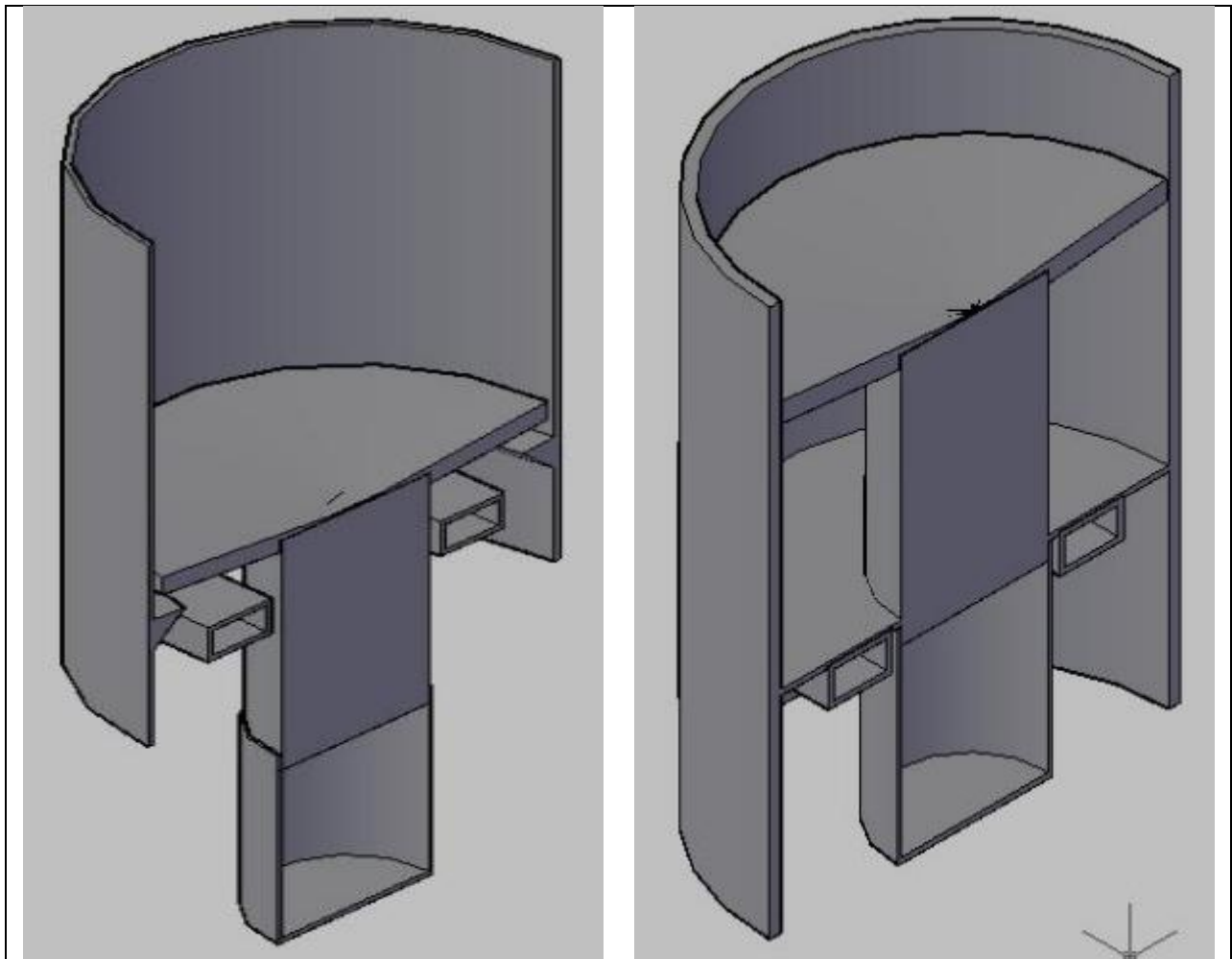

Figure 4: Spring Box System

## 4.2 Final Solution

### 4.2.1 Pin Pusher System

Finally, the pin pusher system was investigated. This system is the most efficient electric system that was investigated. This system stacks the pins up in a row the width of the pans and pushes the entire row into the pan in one motion. This is repeated as the pan is incrementally lowered until it is completely full, and then moves out of position via a conveyor belt and a empty pan moves into position to accept pins. The system only needs to have empty pans loaded and full pans unloaded at the start or end of each job. It also requires the operator to enter in the job number to allow for the varying pin dimensions and compensate the correct amount. This system is an efficient, low cost solution which maintains the orientation of the pins. Figure 5 shows a representation of the proposed solution.

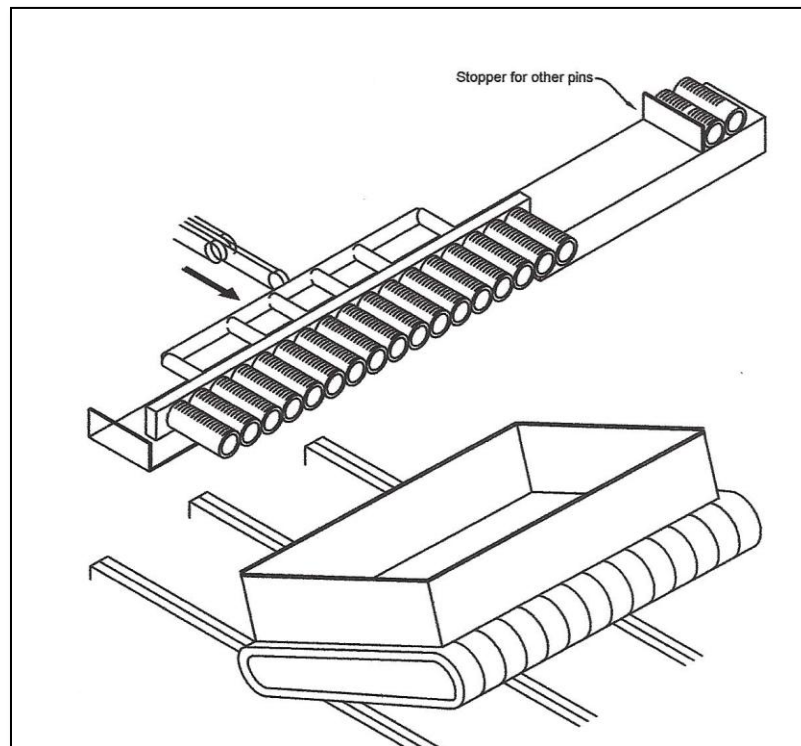

Figure 5: Pin Pusher System

## 5 Conclusions and Recommendations

After considering all the advantages and disadvantages of all the proposed solutions that would be convenient to Burgess-Norton, we conclude that the most effective system to design is the pin pusher system. In this design, all the requirements desired by Burgess-Norton are met: the pins remain oriented, it is relatively low cost, and it makes use of their existing bins. Moreover, at no point are the pins subject to potentially damaging forces or velocities which potentially eliminates any chance for a nick to occur. Additionally, all components are either commercially available or should be relatively simple to fabricate. Figure 8 shows a diagram of the pin pusher part. It makes use of a full stroke actuator to push the pins fully into the pan as well as a secondary actuator to offset the second row of pins to maximize stacking capacity. Additionally, guide rods are implemented to ensure that the pusher does not rack to one side and load the pins unevenly. Figures 6 through 9 show the proposed final solution.

The cost per unit has been estimated to be approximately \$8500 per unit and the yearly cost of electricity has been determined to be less than \$100 per year. These costs provide a low barrier to instituting this design in the plant and should provide a cheap and easy system for future expansion.

For future semesters, the IPRO team can refine the pin pusher system to eliminate any kinks or correct any flaws that have not yet been discovered. Additional semesters could also investigate creating an automated system to unload the pans and fill the heat treat racks to help increase Burgess-Norton's use of automation.

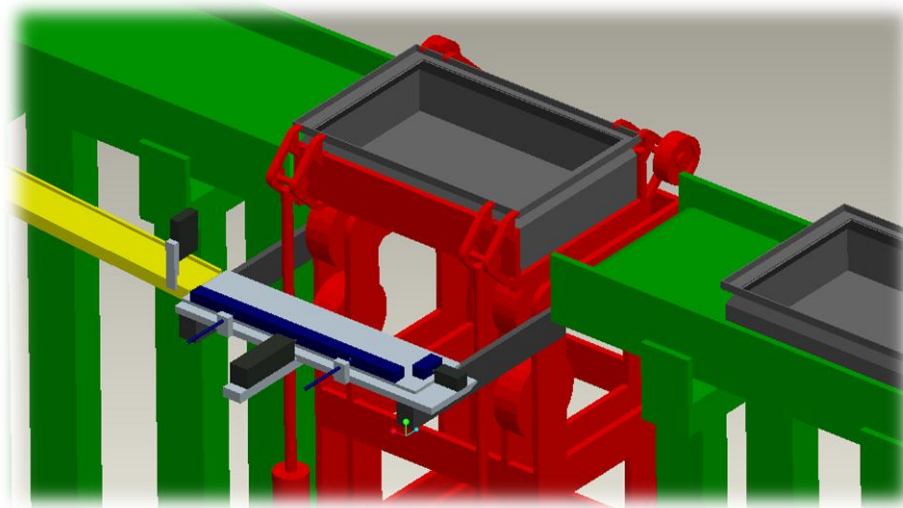

**Figure 6: Schematic of Proposed Solution**

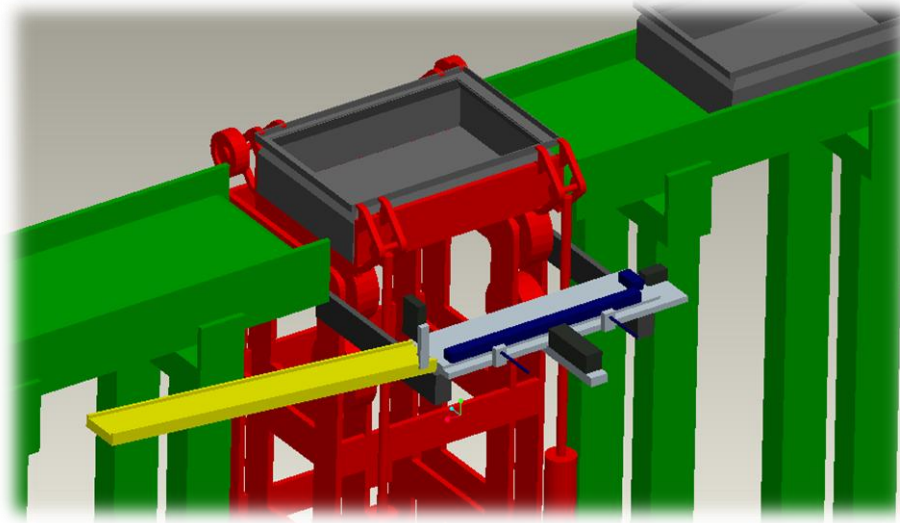

**Figure 7: Another View of Proposed Solution**

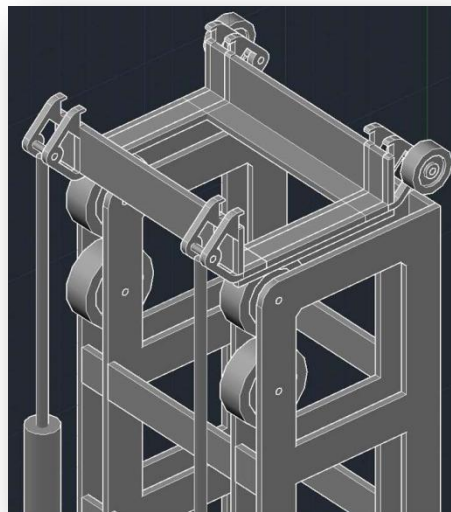

**Figure 8: Close-Up View of Tray Rotator**

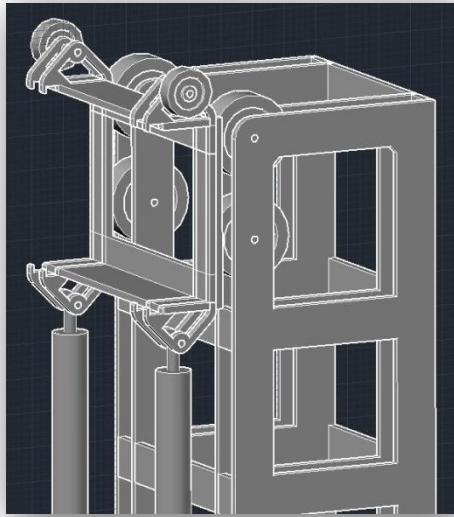

**Figure 9: Another View of the Tray Rotator**

## 6 Appendix

### 6.1 Impact Energy Test Results

	After machining	After heat treating	
		19197	22161
	D = 22.4mm, m = 102.29g	D = 20mm, m = 90.38g	D = 22 mm, m = 104.43 g
E = mgh	0.0848 J	0.1687 J	0.1386 J
Trial 1	3.00 in	7-8 in	5.00 in
Trial 2	4.00 in	7-8 in	5.00 in
Trial 3	3.00 in	7-8 in	6.00 in
Average	3.33 in	7.5 in	5.33 in

### 6.2 Hardness Test Results

After the heat treatment	
On the cylinder end	
19197's	22161
60.0 HRC	59.0 HRC
58.3 HRC	59.5 HRC
58.5 HRC	
59.0 HRC	

After machining, before heat treating	
On the cylinder end	
1	2
9.0 HRC	12 HRC
12 HRC	11 HRC
14 HRC	11 HRC
On the cylinder surface	
15 HRC	

After cold forming, and before machining	
On the cylinder end	
With chamfer	
50.5 HRC	58 HRC
54.5 HRC	57.5 HRC
57.5 HRC	57.5 HRC
57.5 HRC	
On the cylinder surface	
58 HRC	
57 HRC	

Before cold forming
On the cylinder surface
3 HRC

### 6.3 Roster

Name	E-mail	Phone
Akhambay, Assyl	assyl_akhambay@mail.ru	N/A
Barrera, Edilberto	edilbertoba@gmail.com	██████████
Binder, Dylan	dbinder1@iit.edu	██████████
Douh, Wahib	wdouh@iit.edu	██████████
Heo, Yun Seon	yheo1@iit.edu	██████████
King, Terrance	tking2@iit.edu	██████████
Ko, Hyunseok	thardaway1@gmail.com	██████████
Kolesnikov, Andrey	andreyk03@gmail.com	██████████
Simen, Sandrine	simenpeace@gmail.com	██████████
Perle, Collin	cperle@iit.edu	██████████
Truong, Guy	Gtruong@iit.edu	██████████
Ustupski, Krystian	kustupsk@iit.edu	██████████

### 6.4 Budget

Activity	Cost	Description
Testing Expenses	\$0.00	Materials and Apparatus to aid in testing
Design Expenses	\$0.00	Materials used to create final design
Transportation	\$0.00	Transportation reimbursement to and from Burgess-Norton
Poster/IPRO Day Expenses	\$0.00	Office supplies or other items
<b>Total</b>	<b>\$0.00</b>	