

IPRO 344: Improving Audio Quality and Energy Efficiency in Mobile Devices and Intercom Systems.

1. Abstract

IPRO 344 began as an investigation into the applications of Class D amplifiers for low-power and high-quality audio devices. This semester's IPRO will focus on integrating the Class D amplifier into a drive-through order system. In addition to the Class D amplifier, this semester's team will be investigating high-fidelity microphones, microphone preamplifiers, and speaker mounting.

2. Ethics Statement

Overarching Principal: The IPRO 344 team would like to provide the highest quality standards for any industry that uses a drive-through system, as well as enabling the best possible service to customers through clear two way communication.

1. Industry Standards

Cannon: IPRO 344 will work within the standards of the electronic industry, using green technology that is sustainable and renewable.

Pressure: Purchasing and using environmentally friendly parts in the circuitry and kiosk

Pressure: Creating an energy efficient system.

Risk: Creating a system that is not easily duplicated.

Measure: Compliance with the cannon will indicated by the ease of duplication and the acceptance of the system by the electronics industry and drive-through orientated business

2. Community

Cannon: IPRO 344 will hold the satisfaction of the customers using the system in the highest regard.

Pressure: Create clear two way communications between the business and the customer.

Pressure: Ensure the equipment can make the drive-through experience the best it can be.

Risk: Release equipment before it has been thoroughly tested properly in all environments.

Measure: When the system is in use it creates an environment where customers are satisfied with the experience and the drive-through business saves money.

3. Personal Relationships

Cannon: The 344 team will ensure that any communication that takes place between group members or current and potential stake holders will be handled in a respectful and professional manor.

Risk: Team members not asking for help from fellow team members when needed

Risk: Individual team members or the team as a whole communicating with outside stake holders in a non tactful manor.

Pressure: Holding all members with different backgrounds to the same standard.

Measure: Success will result in the working environment where team members feel comfortable and feel they are all being treated fairly. Also communication with outside stakeholders is clear and concise.

3. Background

A. There is commercial interest and value in improving drive-thru systems in terms of the quality of communication, which supports the need for a prototype to explore a range of possible solutions.

B. Shure Inc. provided microphones to the project. IIT ECE department provided a laboratory to the IPRO 344 team for the development of the prototype.

C. The emphasis of drive-thru system operations has been on increasing speed-of-service, which has benefits for both the customer and the service provider. However, improvement in order accuracy is now regarded as at least as important as speed-of-service in delivering value for the customer and assuring efficient operations for the service provider.

For example:

1. Environmental interference interrupts the communication between the customer and the clerk:
 - a. Heavy rain/wind.
 - b. Engine noises.

2. Customer's position relative to kiosk makes the communication difficult:
 - a. Customer parks too far from the kiosk.
 - b. Customer is not speaking into microphone.

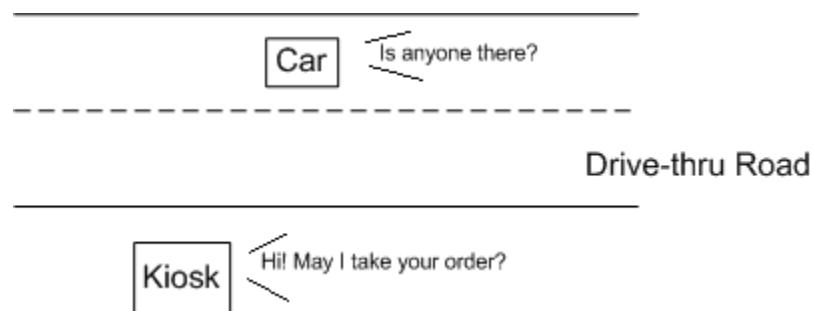

In previous semesters, IPRO 344 studied class-D amplifier audio quality as compared to Class AB and class B. The team then began the process of modeling a two-way communication system. Specialized preamplifiers were constructed for the headset and kiosk microphones. Weatherproof speakers were located and wired for the system prototype. An entire kiosk model was constructed and demonstrated on IPRO day.

4. Objectives

The IPRO 344 team has set forth the following objectives for the overall project and the 2009 spring semester, as well as the expected results for the semester:

6. Team Structure and Assignments

Name	Major, Year	Skills and Strength	Experience and Academic Interest	Team Responsible	Other Team involvements
Raza, Mohammad	BME/EE, 4th year	Fabrication, soldering, Matlab, Labview	Signal Processing, Neuroscience, Returning member of ipro 344	Tools and Media	Circuits and signal processing, research, documentation
Aigner, Jeff	CPE, 3 rd Year	Electronics design and implementation, Web Design, Programming (HTML/CSS, Javascript, C, C++, Java, Perl, Python, Assembly, SQL), system administration on FreeBSD and GNU/Linux	Signal Processing, Distributed Systems, Digital Systems, 6 years industry experience programming (mostly PHP and SQL), research work for the WiNCOM laboratory, signal processing and microelectronics courses	Web	Circuits and signal processing, research, minutes
Gullikson, Kevin	Physics, 3rd year	Fabrication, C, C++, Python, GNU/Linux	Acoustics, Returning member of ipro 344	Kiosk Modification/Testing	Documentation, Research, Minutes
Su, Yihan	Applied Mathematics, 4 th year	Some C++, Alice, and little Matlab	Probability, statistics, Alice, three months accounting assistant, 5 years hotel waiter	Economic	Purchasing and poster
Craig, Titilayo	CS/AM, 3 rd year	Programming in java, matlab, a little bit of PHP and currently working with C	Numerical analysis, Software Engineering	Purchasing	Web, Poster

Kuo, Steve	ARCH, 4 th year	Auto CAD, Adobe photoshop, Illustrator, 3d Max	Residential building design	Project Coordinator	Purchasing, Implementation-System Integration and Testing
Chiles, Jeff	EE/CPE 2 nd year	Java, Python, C, AS 3.0, Assembly, microcontrollers, fabrication	Electromagnetics, Electronic Warfare, Optics, Digital Systems, IT Internship with VOA Associates, Inc.	Implementation - Circuits and Signal Processing	Research, Tools and Media
Barnett, Alex	EE/CPE, 3 rd year	Audio Electronics design, audio equipment knowledge	Electronics, Signal Processing, Electromagnetics, Returning member of ipro 344	Research	Circuits and signal processing, research, System integration and testing
Walker, Alex	POLSC, 4 th year	Practical application of organization and leadership, non-engineering viewpoint, wood/metal fabrication experience	Constitutional law	Documentation	Tools and Media

Sub-Team 1: Circuit and Signal Processing Team

Purpose: This team will work to improve the following aspects of the intercom system for IPRO 344: Audio Signal Fidelity, Speech Intelligibility, Reliability of electronic components in extreme conditions, Filtering of unwanted ambient sound, Filtering of erroneous signal noise, Clarity of dialog, Reduction of feedback, and Upgrades to the electronic system, directed at these criteria, will ultimately improve the overall usability and quality of the project.

Team Members:

- Mohammad Raza
- Jeff Aigner
- Alex Barnett

Tasks:

*Prepare a second copy of the entire electronic system. This will allow testing to be done simultaneously with upgrades to the main circuit.

*Coordinate with the Kiosk Modification team to quickly mount the electronics in a more easily accessible position, so that the following upgrades may be performed without difficulty.

*Integrate a three-channel mixer component into the system, enabling testing for white-noise applications.

*Integrate a white-noise generator as an input to the mixer component.

*Implement a graphic equalizer that follows the mixer. This will allow frequency response testing to be conducted for improvements to speech intelligibility.

*Implement and integrate a gate-system to isolate one person's speech at a time (or a different etiquette), enabling better clarity of dialog and reducing feedback.

*Coordinate with the testing team to predict sources of distracting noise for the intercom, such as different types of car engines and high-speed winds. Isolate the characteristic audio components of these signals and develop filters to remove them from the output.

*Receive information from 343 and testing conducted in 344. Calibrate equalizer, speech gate, white noise, and filters to improve the results indicated by the test.

*Make the intercom system more easily operated by changing the control circuitry.

Sub-Team 2: Economic Team

Purpose: The objective of the Economic team is to assess the economic feasibility of implementing the project in an actual franchise.

Team Members:

- Yihan Su – Team Leader
- Jaroslaw Suwada

Tasks:

- Come up with a franchise scale cost estimate for the kiosk system.
- Working with the purchasing team to decide what price item we are going to use.
- To detail the advantage and disadvantage of different model of the same item by communicating with the research team.
- Calculate the cost of the product, and profit if put this product to the market.

Sub-Team 3: Documentation Team

Purpose: The objective of Documentation team is to create and maintain all documents related to IPRO 344 through official channels. The collected document help next IPRO team understand the purpose of IPRO 344 and identify the progress of it.

Team Members:

- Alex Walker
- Kevin Gullikson
- Raza, Mohammad

Tasks:

- Collect and maintain all documents.
- Support Poster team for offering information to make a poster.
- Support Presentation team for preparation of presentation.
- Production of project plan and final report
- Development of brochure and CD

Sub-Team 4: Kiosk Modification/Testing Team

Purpose: The purpose of the Kiosk Modification and Testing team is to make the kiosk easier to test by creating easier access to the electronics, as well as the speaker and microphone compartments, and to perform quantitative tests on both the old and new kiosks.

Team Members

- Kevin Gullikson
- Yihan Su
- Steve Kuo
- Alex Barnett

Tasks: The following are tasks for the Kiosk team to complete

1. Modify kiosk to provide easier access to the electronics, the microphone, and the speaker compartments. This was done by making a new back panel that slides off and on. In addition, it is split into a bottom half and a top half, so that the bottom can be removed to provide access to the electronics, while the top half is in place and acoustically sealing the microphone and speaker.
2. Line the acoustic chambers with a metallic substance. This is to more accurately simulate the acoustic properties of the chambers in metal kiosks being used by fast food and banking drive-through systems.
3. Perform acoustical tests of the system.

Sub Team 5: Project Coordination

Purpose: The main purpose of the Project Coordination team is to make sure each sub team follows the schedule of their tasks, and to make sure everyone finish their job on time. Project Coordination team needs to check with teams every week to let them know which task they should be on right now and how long it should take to finish it.

Team Members:

1. Steve Kuo
2. Tao Shen

Tasks:

1. Send out emails every week to remind the teams the timeline of their tasks.
2. Update the calendar on igroup website so it's easy to find out the project due dates.
3. Remind everyone the important due dates such as midterm and ipro day.

Sub-Team 6: Poster Board

Purpose: Produce a poster board for IPRO day that will provide necessary information as to what has been accomplished, what the goals of the team were, and provide conceptual information on the project itself.

Team Members:

- Jaroslaw Suwada (Team Leader)
- Titilayo Craig
- Yihan Su

Various Tasks:

- Work with presentation and documentation team to extract relevant material for displaying.
- Create a poster board for IPRO day.
- Provide clear concise information along with photographs.

Sub-Team 7: Purchasing Team

Purpose: The purchasing team is in charge of getting all equipment needed for the project. The purchasing team is responsible for sending the list of items needed to the IPRO office for purchase. In the event that the item needs to be purchased individually, the purchasing team is responsible for getting the needed item and submitting the receipts for all reimbursement to the IPRO office. Also, the purchasing team is in charge of the team's budget.

Team Members:

- Titilayo Craig
- Steve Kuo
- Yihan Su

Task:

- Acquire list of all items needed from each team.
- Prepare team budget for the semester.

- Search necessary sites in which items can be purchased and the prices of each item.
- Send request to IPRO Office for purchase and follow up on details of purchase.
- Interact constantly with all other sub-teams to ensure all items needed through out the semester is purchased.

Sub-Team 8: Research Team Responsibilities

Purpose: The research team provides information for other teams to utilize in the project implementation. The research team will utilize datasheets, web tutorials, journals, and published research to collect and convey data to the rest of the group, emphasizing the Circuit and Kiosk Testing teams.

Team Members:

- Alex Barnett
- Jeffrey Aigner
- Kevin Gullikson
- Mohammad Raza

Tasks:

- Acquire knowledge or studies of acoustic intelligibility to aid in developing kiosk standards.
- Acquire knowledge of common practice microphone and speaker mounting techniques for intercom systems.
- Acquire knowledge to supplement signal processing efforts by circuit team, i.e. the frequency response of diesel engines or male/female voice.

Designation of Roles:

Agenda Maker- Steve Kuo

Time Keeper- Kevin Gullikson

Filing and Organizing Weekly Timesheets- Alex Barnett

Weekly Task Lists- Kevin Gullikson

iGroups Coordination- Titilayo Craig

Master Schedule Maker- Steve Kuo

IPRO344 Representative/Presenter- Alex Barnett

7. Budget

Below is the submitted projected budget of IPRO 344

Category	Amount(\$)	Explanation
Supplies	94.28	Shure Microphone Preamp equipments
Equipments	48.33	Headset microphones Preamplifier equipment
System Items	327.68	Additional Items
Miscellaneous Items	259.99	Printed circuit boards
Kiosk Material	136.01	Kiosk materials quantity
Signal Processing Expenses	92.04	Materials needed for the signal process system.
Additional Materials	42.46	Items from Digikey
USB Microphone Preamp	189.94	For testing part descriptions
TOTAL	1190.73	

However, the total amount budgeted was not fully spent. The total amount spent this semester by IPRO 344 was **\$923.65**.

Below is the total number of orders placed and reimbursement issued by the IPRO office:

1) 6pc set of 24"x24" 2" wedges (Sonitec) \$57.75

2) Mouser Order Description:

Shure Microphone Preamp				
Part	Description	Price	Quantity	P*Q
71-CMF551K0000BHEB	1/8W .1% 1k resistor	\$0.36	8	\$2.88
71-RN60C-B-20K/R	1/8W .1% 20k resistor	\$0.34	8	\$2.72
71-CMF5510K000BEEB	1/8W .1% 10k resistor	\$0.52	12	\$6.24
660-MF1/4DCT52R1500F	1/4 1% 150 resistor	\$0.05	12	\$0.60
594-5073NW200R0J	200 ohm 5%	\$0.16	4	\$0.64
594-5073NW820R0J	820 ohm 5%	\$0.16	4	\$0.64
660-MF1/4LCT52R222J	2.2k 5%	\$0.05	4	\$0.20
71-	5k 5%	\$0.18	2	\$0.36

CMF075K0000JNEK				
594-5073NW20K00J	20k 5%	\$0.16	4	\$0.64
71-CCF02100KJKE36	100k 5%	\$0.19	4	\$0.76
863-LM833NG	dual LM833 opamp	\$0.91	6	\$5.46
523-AC3FDZ	xlr female connector	\$3.96	2	\$7.92
502-BPJF02X	rca female connector	\$1.70	2	\$3.40
270-6.81K-RC	6.81k .5% phantom resistor	\$0.15	8	\$1.20
647-UPM1J680MPD6	68uF 63v Polar Electrolytic Capacitor	\$0.49	3	\$1.47
108-0038-EVX	spst switch toggle 5a	\$2.83	4	\$11.32
647-UVP1E100MDD	10uf bipolar electrolytic	\$0.19	4	\$0.76
647-UVP1C101MPD	100uf bipolar electrolytic	\$0.27	10	\$2.70
313-1520F-10K	10k Audio Pot Solder lugs	\$1.50	4	\$6.00
647-UVP1V220MED	22uf bipolar electrolytic	\$0.26	10	\$2.60
575-343308	IC socket 8P dip	\$1.03	6	\$6.18
647-UKT1V470MDD	35 V, 47 uF, Audio Electrolytic Cap	\$0.15	12	\$1.80
81-RPER71H104K2P1A03	Monolithic Multilayer 0.1uF	\$0.13	12	\$1.56
647-UVP1H010MDD	Bi-Polar Electrolytic Capcitors	\$0.19	4	\$0.76
81-DEA1X3A270JC1B	27pf Ceramic caps	\$0.11	4	\$0.44
313-2000F-25K	25k Linear Pots	\$1.68	8	\$13.44
80-C315C220J5G	22pf ceramic caps	\$0.23	4	\$0.92
571-1825093-3	14 dip IC socket	\$0.53	2	\$1.06
610-1N4627	0.25 W 5% Zener Diodes	\$0.23	8	\$1.84
			Subtotal	\$86.51
			Shipping	\$7.77
			Total	\$94.28
Headset mic Preamp				
Part	Description	Price	Quantity	P*Q
512-NE5532N	5532 dip op amp	\$0.51	4	\$2.04
291-10K-RC	10k 5% 1/4 w resistor	\$0.10	30	\$3.00
291-1.5K-RC	1.5k 5% 1/4 w resistor	\$0.10	4	\$0.40
291-27K-RC	27k 5% 1/4 w resistor	\$0.10	12	\$1.20
291-33K-RC	33k 5% 1/4 w resistor	\$0.10	8	\$0.80
291-100-RC	100 5% 1/4 w resistor	\$0.10	4	\$0.40
313-1520F-10K	10k Audio Pot Solder lugs	\$1.50	14	\$21.00
647-UST1H2R2MDD	2.2uf polar electrolytic	\$0.18	8	\$1.44
625-1N5617	1amp 400v diode	\$0.40	4	\$1.60
647-UPM1J470MPD	50uF Capacitor	\$0.45	4	\$1.80
598-SK100M035ST	10uf electrolytic polar cap	\$0.13	4	\$0.52
16PJ108-EX	3.5mm jack	\$1.59	4	\$6.36
			Subtotal	\$40.56
			Shipping	\$7.77

			Total	\$48.33
Additional System items				
595-TPA3101D2EVM	Eval board with class D	\$169.68	1	\$169.68
			Grand Total	\$312.29

3) Digikey Order

Index	Quantity	Part Number	Description	Customer Reference	Backorder Quantity	Unit Price USD	Extended Price USD
1	10	P3P5103-ND	POT 10K OHM 9MM HORZ NO BUSHING		0	0.84900	\$8.49
2	10	1N752A-ND	DIODE ZENER 5.6V 500MW 5% DO-35		0	0.05900	\$0.59
3	3	LM837N-ND	IC OP AMP QUAD LOW NOISE 14-DIP		0	1.71000	\$5.13
4	4	CT2159-ND	POT 10K OHM 5W WIREWOUND W/HRDWA		0	3.61000	\$14.44
5	12	CT2257-ND	POT 100K OHM 1/8W CARB HORIZ		0	1.26000	\$15.12
6	4	ATMEGA168- 20PU-ND	IC AVR MCU 16K 20MHZ 28DIP		0	4.11000	\$16.44
7	4	X116-ND	OSC 16.000 MHZ 5.0V FULL SIZE		0	1.88000	\$7.52
8	10	P3471-ND	.00047 UFD POLYPROPYLENE CAP		0	0.19900	\$1.99
9	10	P4725-ND	CAP .1UF 100V STACK METAL FILM		0	0.12500	\$1.25
10	10	P833-ND	100UF 16V MINI ALUM ELECT (KA)		0	0.10200	\$1.02
11	10	P807-ND	10UF 16V MINI ALUM ELECT (KA)		0	0.09100	\$0.91
12	4	P3102-ND	.001 UFD POLYPROPYLENE CAP		0	0.46000	\$1.84
13	10	P3271-ND	.00027 UFD POLYPROPYLENE		0	0.19900	\$1.99

			CAP				
14	10	P4556-ND	CAP .0027UF 50V POLYESTER		0	0.07200	\$0.72
15	5	P3821-ND	.00082 UFD POLYPROPYLENE CAP		0	0.23000	\$1.15
16	10	P4719-ND	CAP.033UF 100V STACK METAL FILM		0	0.15100	\$1.51
17	10	P4713-ND	CAP .01UF 100V STACK METAL FILM		0	0.12800	\$1.28
18	10	P4518-ND	CAP .027UF 50V STACK METAL FILM		0	0.12800	\$1.28
19	10	P4731-ND	CAP .33UF 100V STACK METAL FILM		0	0.17900	\$1.79
20	3	P3822-ND	.0082 UFD POLYPROPYLENE CAP		0	0.49000	\$1.47
21	3	PF2105-ND	CAP 1.0UF 250V METAL POLYPRO		3 Lead Time	0.79000	\$2.37
22	10	1.0KH-ND	RES 1.0K OHM 1/2W 5% CARBON FILM		0	0.05800	\$0.58
23	4	CD4066BCN- ND	IC SWITCH BILATERAL QUAD 14-DIP		0	0.45000	\$1.80
24	12	A31120-ND	CONN RECEPT 2POS 22AWG MTA100		0	0.22000	\$2.64
25	12	A1911-ND	CONN HEADER VERT 2POS .100 TIN		0	0.21000	\$2.52
26	10	A31089-ND	CONN RECEPT 3POS 22AWG MTA100		0	0.22000	\$2.20
27	10	A31113-ND	CONN HEADER VERT 3POS .100 TIN		0	0.22000	\$2.20
28	3	P3C3103-ND	POT 10K OHM 9MM VERT NO BUSHING		0	0.99000	\$2.97
Total							\$103.21

4) Reimbursements

Item	Amount
½” Birch Plywood 5x5	\$42.50
60” x 49”x ¼ “MDF	\$12.25
Total	\$54.75

5) Power supply:

Part	Description	Price	Quantity	P*Q	Supplier
PS65-15	15V 65W power supply	\$36.00	1	\$36.00	Astrodyne
PT45-C	15,5,-15 45W power supply	\$40.00	2	\$80.00	Astrodyne
	Total Price			\$116.00	

6) Microphones

Part	Description	Price	Quantity	P*Q	Shipping	Supplier
MXLUSBMICMATE	USB Mic Preamp	49.95	1	49.95	4.99	ZZOUNDS
SM4006	Measurement microphone and preamp	\$125.00	1	\$125.00	\$10	Scantek Inc
ZZounds total	\$54.94					
Scantek Inc total	\$135.00					

7) Mouser Chassis Order Description:

Item	No	Price	QTY	Price*qty
Mixer Chassis	546-1456KK4WHBU	35.67	1	35.67
Kiosk Chassis	546-1458G3B	49.04	1	49.04
			Total	84.71

This order did not take shipping into account.

8. Results

Progress towards goals:

Kiosk

Figure 2 below shows a layout of the new kiosk. The height, width, and depth of the kiosk were chosen to be the same as the kiosk made last semester, which was itself based on measurements of an actual McDonalds kiosk. We decided to keep the physical dimensions the same in this kiosk as they were in the old one, so the two systems would be directly comparable. Different physical dimensions could give different acoustical properties, which would be a poorly controlled variable in testing. This kiosk contains four separate compartments. First, a microphone compartment. This is where the microphone goes, as well as any foam insulation. Second is a compartment for the lcd screen that most kiosks have for the customer to check their order. We will not actually be using an lcd screen, but we left space for it to make the kiosk physically similar to one found in use. The third compartment is the speaker compartment, which contains the speaker and any foam insulation used. Finally, the bottom of the kiosk is reserved for electronics. The size and location of each of these compartments can be varied, as will be discussed below. The current set-up for the new kiosk is with the microphone on top, followed by the lcd screen area, then the speaker, and finally the electronics.

The new kiosk has the following features that allow it to be highly customizable and easy to use.

1. Fully removable front and back panels. Last semester's kiosk had front and back panels that were screwed on, which made them difficult to remove for access to the components inside. This semester, the front and back panels were designed to slide off to provide easier access to the components.
2. This semester, we made two back panels of roughly half the total height instead of one full height back panel. Since the electronics are on bottom, it is desirable to have the bottom completely accessible while the top, which contains the microphone and speaker, are acoustically sealed. Using only one of the two back panels accomplishes this.
3. Adjustable shelf heights. We designed this kiosk with removable shelves, so that the dimensions of each compartment can be varied. This can change the acoustical properties of the compartments, potentially leading to a set of dimensions that give the best results. These could go into a standard that we set for kiosks, which is one of the ultimate goals of IPRO 344.

In order to make the kiosk similar to one being used today, we purchased aluminum to be placed on the inside of the microphone compartment. Metal has different acoustical properties to wood, and we wanted to replicate these properties in our kiosk. We purchased acoustical foam to place in the microphone compartment, in order to reduce any reverberation of sound that would lower the intelligibility of the system. We also purchased r-19 insulation for the speaker compartment to acoustically separate it from the microphone compartment and to enhance the low frequency response of the speaker.

Testing

The research team had a significant impact on the development of the testing procedure. They found two speech intelligibility standards: The Speech Intelligibility Index (SII) and the Speech Transfer Index (STI). We chose to use the STI because it is an international standard rather than a US standard, and because we found a user-friendly program that does most of the testing called LexSTI. The procedure for testing is shown below. Figure 2 illustrates how the system should be set up for testing.

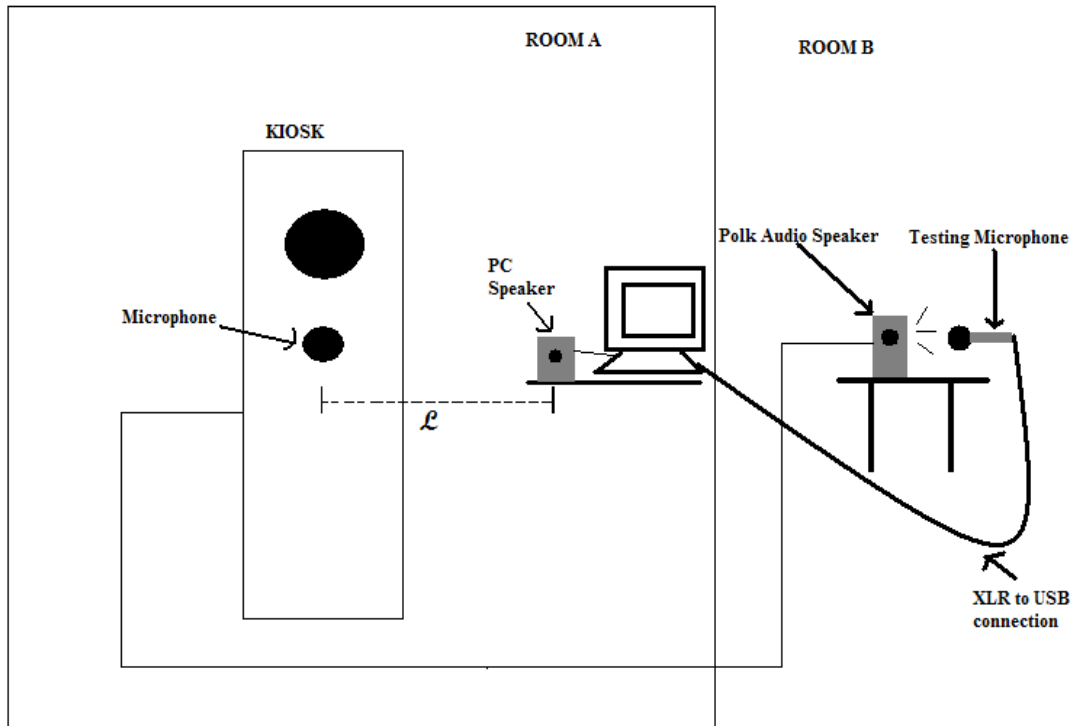

Figure 1: Testing Diagram

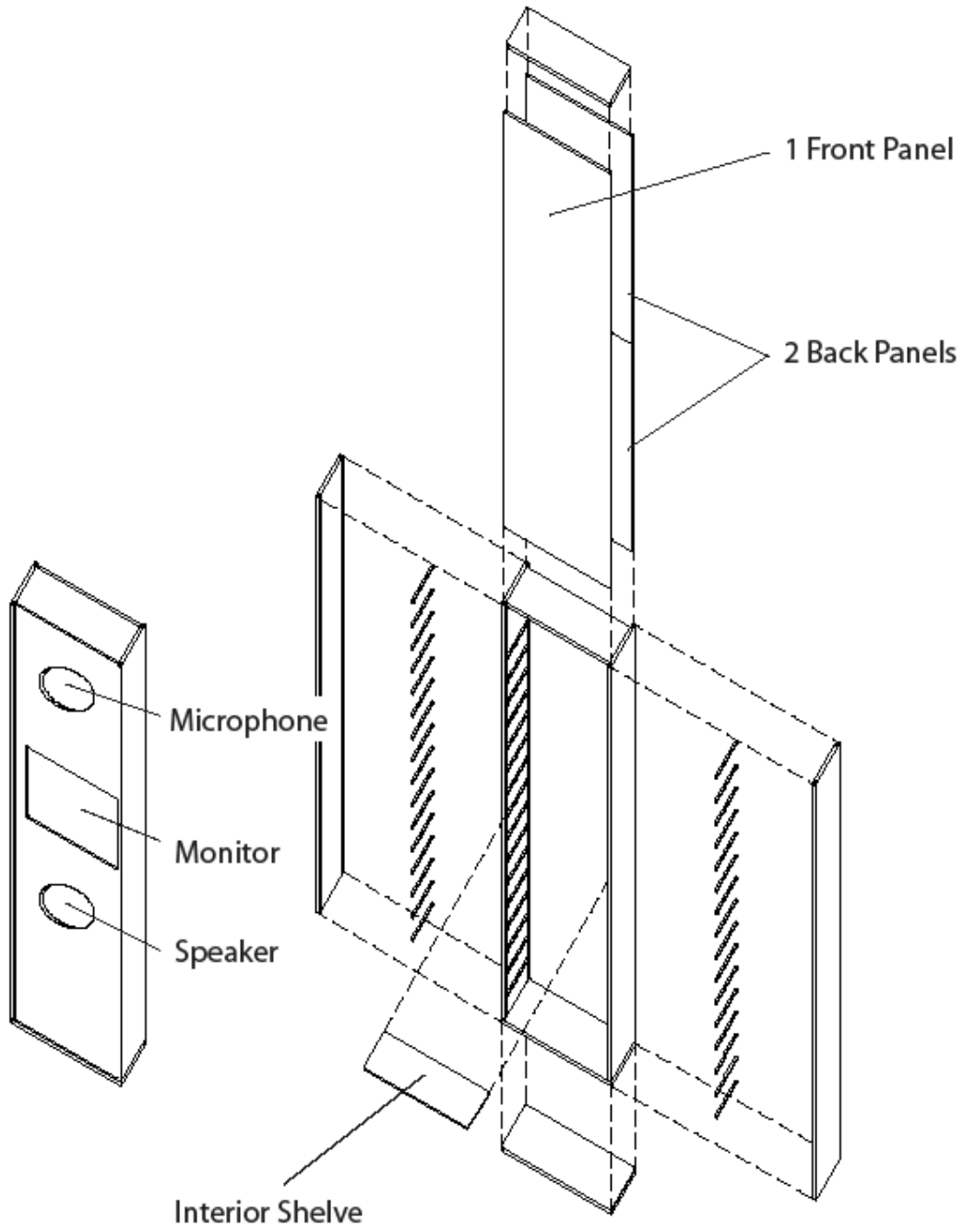

Figure 2: New Kiosk Design

<u>Hardware</u>	<u>Software</u>
Kiosk to be Tested	LexSTI
PC/Laptop w/ Windows OS	TruRTA
Polk Audio Speakers w/ cables	Audacity
Testing Microphone w/ xlr-usb connector	Windows Media Player
Sound Calibrator	Windows Sound Recorder
PC speaker	
Meter Stick	

Methodology

1. Connect Test Microphone to PC
2. Wait for driver to install
3. Set sound playback as the default sound device and sound recording for the USB testing Microphone.
This can be done using Windows Sound Recorder --->Edit --->sound properties.
4. Set up system as seen in testing diagram.
 - I. The Kiosk should be in the room with the computer/pc speaker
 - II. The Polk Audio Speakers should be in another room with the test microphone.
 - III. Measure the distance from the PC speaker and the center of the opening for the Kiosk Mic.
 - IV. Make sure testing microphone is in a level position in front of Polk Audio Speaker.
5. Obtain level.wav file from the LexSTI program.
6. Loop this file in Windows Media Player or other Audio playing device.
7. Launch Audacity and observe whether sound is clipping.
8. If sound is clipping decrease sound level from PC speaker until sound is just below clipping level.
9. Close Media Player and Audacity.
10. Launch LexSTI.
11. Begin Measuring with 2-4 trials.
12. Specify file name and test parameters.
13. After measuring procedure is over press analyze.
14. Specify file to be analyzed eg:(response.wav).
15. The STI report will appear in analysis.log by default; this can be changed in the analyze dialog box.
 - V. Post processing of response file. (if response file does not get analyzed)
16. Download folder for lexSTItool.
17. Make sure folder contains front.mat and end.mat.
18. Set path to folder in Matlab command prompt ex: path(path, 'c:\containing folder')
19. Type lexSTItool.
20. It will ask for file name to be analyzed, enter in the following format: 'respons34.wav'.
21. Make sure wav file is in directory or else set path to it.
22. The program will save the output as the same name as the input.
23. Proceed with analyzing the file in lexSTI.

Preliminary Testing Results

The new kiosk took much longer to construct than we anticipated, and so we were not able to complete as much testing as we would have liked. However, here are the results of what testing we were able to perform.

Old Kiosk

Test	Mic (O/C)	Speaker-Kiosk Distance (normal)	Speaker Distance Off axis Horizontal	Speaker Distance off Normal (Vertical)	Diesel Source Distance (Normal)	Diesel Source Distance off Axis Horizontal	Diesel Source Distance off Axis to vertical
1	C	49.0cm	0	26.9cm	NA	NA	NA
2	C	49.0cm	0	26.9cm	NA	NA	NA
3	O	35.5cm	0	22.5cm	NA	NA	NA
4	C	35.5cm	0	22.5cm	NA	NA	NA
5	C	35.5cm	0	22.5cm	NA	NA	NA
6	O	35.5cm	0	22.5cm	NA	NA	NA
7	O	35.5cm	0	22.5cm	NA	NA	NA
8	C	35.5cm	0	22.5cm	NA	NA	NA
9	C	35.5cm	0	22.5cm			
10	O	35.5cm	0	22.5cm			
11	O	35.5cm	0	22.5cm			
12	C	35.5cm	0	22.5cm			
13	C	35.5cm	0	22.5cm			
14	O	35.5cm	0	22.5cm			
15	O	35.5cm	0	22.5cm			
16	C	35.5cm	0	22.5cm			

Test	Mic To Front Panel Distance	Damping Material	Eq	STI	Notes
1	4.5cm	Auralex Foam	NA		MXL MicMate High
2	4.5cm	Auralex Foam	NA		MXL MicMate Low
3	4.5cm	Auralex Foam	NA		MXL MicMate Low
4	4.5cm	Auralex Foam	NA		MXL MicMate Low
5	3.5cm	Auralex Foam	NA		MXL MicMate Low

6	3.5cm	Auralex Foam	NA		MXL MicMate Low
7	6cm	Auralex Foam	NA		MXL MicMate Low
8	6cm	Auralex Foam	NA		MXL MicMate Low
9	9cm	Auralex Foam	NA		MXL MicMate Low
10	9cm	Auralex Foam	NA		MXL MicMate Low
11	9cm	No Insulation	NA		MXL MicMate Low
12	9cm	No Insulation	NA		MXL MicMate Low
13	6cm	No Insulation	NA		MXL MicMate Low
14	6cm	No Insulation	NA		MXL MicMate Low
15	3.5cm	No Insulation	NA		MXL MicMate Low
16	3.5cm	No Insulation	NA		MXL MicMate Low

Effect of Foam Insulation for Cardioid Microphone

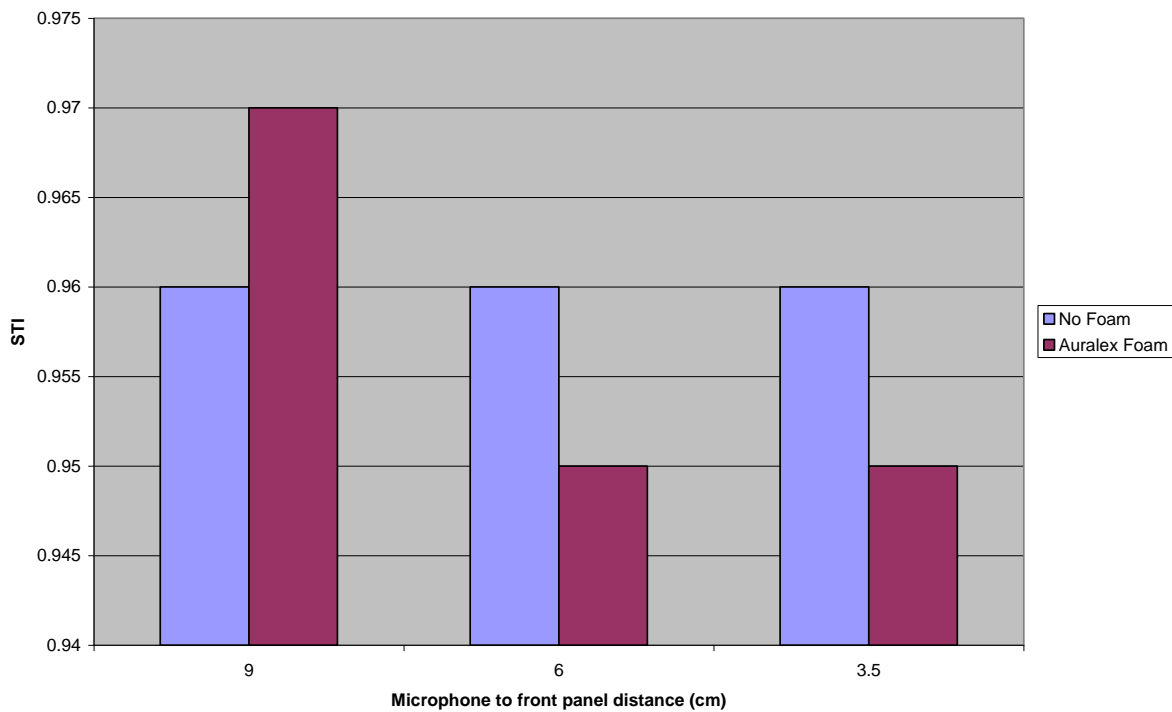

Effect of Foam Insulation for Omnidirectional Microphone

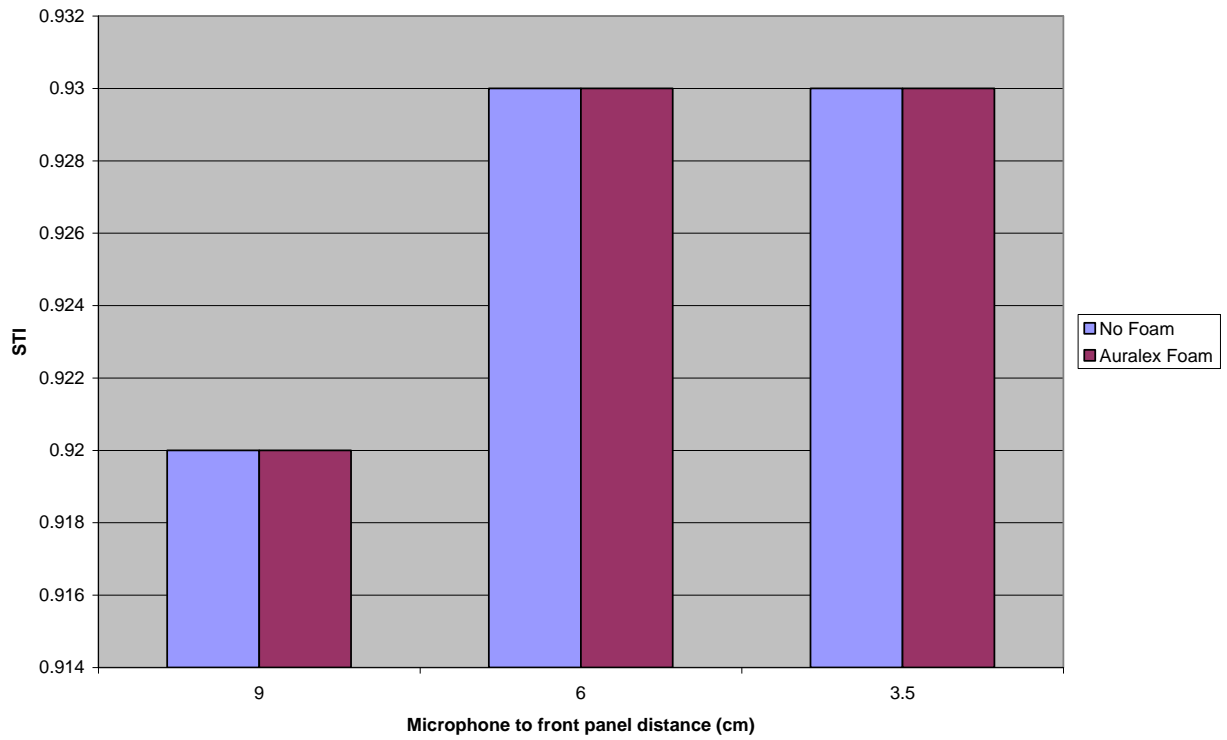

STI for Cardioid and Omnidirectional Microphones

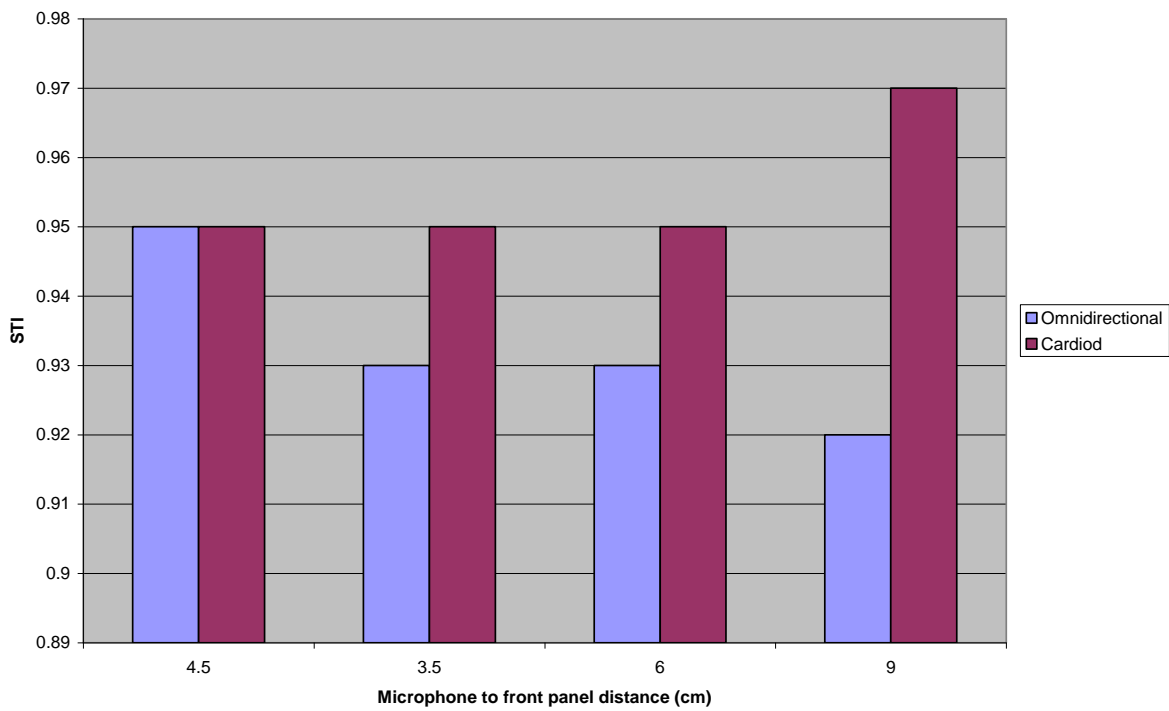

New Kiosk

Test	Mic (O/C)	Speaker-Kiosk Distance (normal)	Speaker Distance Off axis Horizontal	Speaker Distance off Normal (Vertical)	Diesel Source Distance (Normal)	Diesel Source Distance off Axis Horizontal	Diesel Source Distance off Axis to vertical
1	C	49.5cm	0	13cm	NA	NA	NA
2	C	49.5cm	0	13cm	NA	NA	NA
3	C	49.5cm	0	13cm	NA	NA	NA
4	O	49.5cm	0	13cm	NA	NA	NA
5	O	49.5cm	0	13cm	NA	NA	NA
6	O	49.5cm	0	13cm	NA	NA	NA
7	O	49.5cm	0	13cm	NA	NA	NA
8	O	49.5cm	0	13cm	NA	NA	NA
9	C	49.5cm	0	13cm	NA	NA	NA
10	C	49.5cm	0	13cm	NA	NA	NA

Test	Mic To Front Panel Distance	Damping Material	Eq	STI	Notes
1	5.5	Auralex Foam	NA	0.87	NA
2	3.5	Auralex Foam	NA	0.86	
3	9	Auralex Foam	NA	0.88	
4	3.5	Auralex Foam	NA	0.77	
5	5.5	Auralex Foam	NA	0.76	
6	9	Auralex Foam	NA	0.76	
7	9	Metal (None)	NA	0.74	
8	3.5	Metal (None)	NA	0.77	
9	9	Metal (None)	NA	0.87	
10	3.5	Metal (None)	NA	0.83	

Effect of Foam Insulation for Omnidirectional Microphone

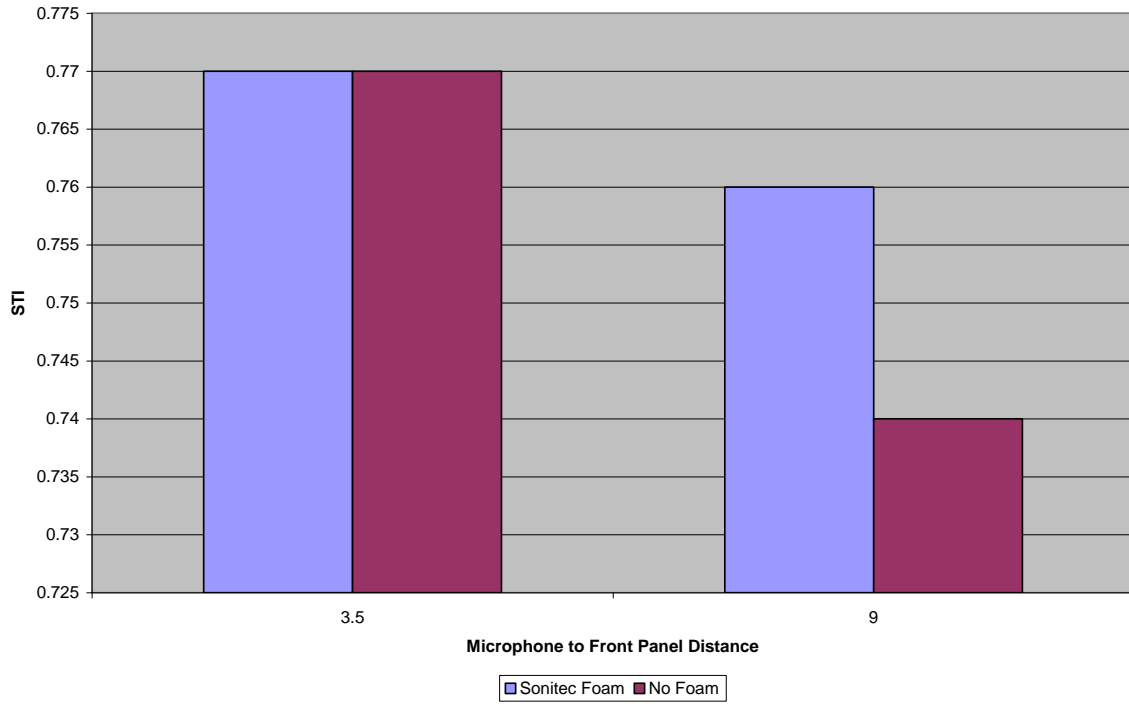

Effect of Foam Insulation of Cardioid Microphone

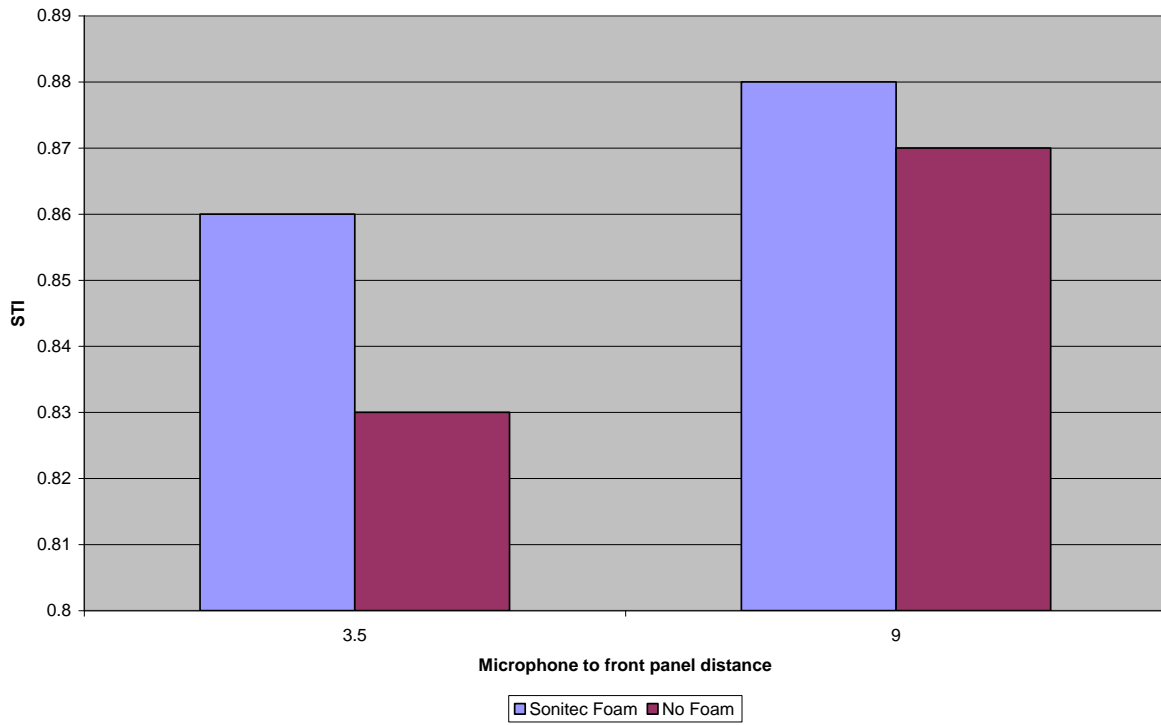

STI for Cardioid and Omnidirectional Microphones

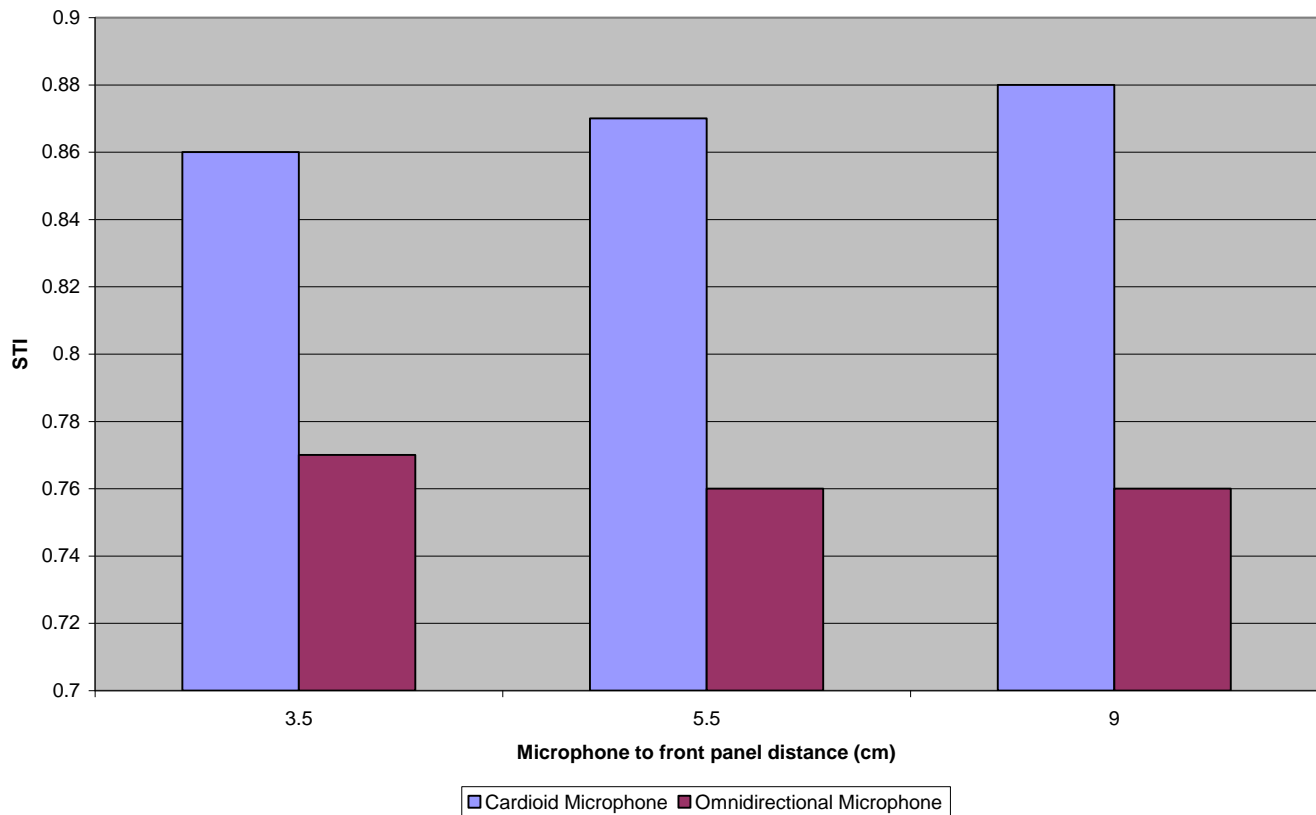

Circuit/Signal Overview

The Circuits and Signal Processing team's primary purpose was to produce a new version of the electronic intercom with improved accessibility, reliability, and tone control. After the implementation of the stereo mixer, graphic equalizer, and speech-gate controller, redesign of the circuits, and construction of the final modules, this purpose was well-fulfilled through the semester's work.

Redesign of system layout

The initial configuration of the intercom system placed all the electronic modules in the kiosk (the enclosure that is placed outside), primarily for the purposes simplifying the system to the user. Assuming the device runs flawlessly for most of its operational lifetime, this is a logical and simple arrangement.

However, any electronic failure requires a complete disassembly of the entire system, and any physical damage to the kiosk could result in unnecessary damage to additional components.

A new design was developed to alleviate these issues. A facility employing this intercom would place one module, known as the Server-Side Module (SSM), inside the building. This contains a Class-D amplifier for the indoor loudspeaker, a preamp, and any other audio-processing modules implemented. It is connected by an audio signal cable to the second module, the Client-Side Module (CSM), that is stored in the kiosk outside the building. The CSM includes a specialty preamp for the microphone and another Class-D amplifier to power the intercom loudspeaker. The result of this configuration is a clean separation of the system functionality. Various adjustments to system parameters can be made from within the building without having to tamper with the SSM, allowing the company to optimize the sound quality for maximum intelligibility.

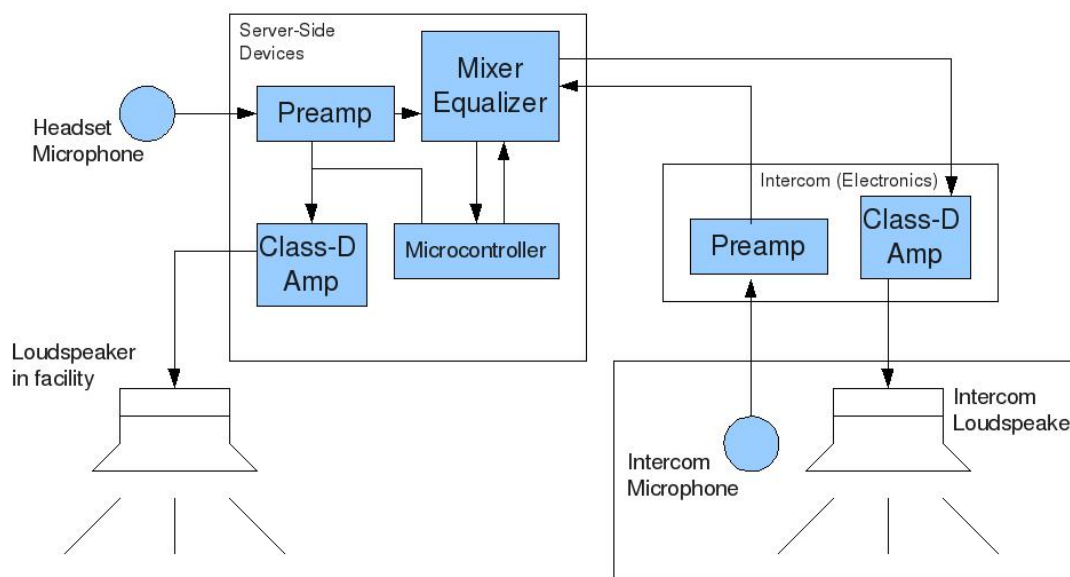

System-level Block Diagram

Evaluation of electronic upgrades

The intercom system inherited from the previous semester succeeded in the basic responsibilities expected of such a system: sound is cleanly transmitted in two directions over a distance using a Class-D amplifier. Although the layout used was effective and sufficiently reliable for basic testing, the only variable that could be controlled by an employee utilizing the device (herein referred to as simply the employee) was the volume of the customer's voice. To make the intercom system more robust, various electronic upgrades were considered:

5. White Noise Generator: Research received from the IPRO 343 team in the previous semester indicated that white noise injected into the “mix” heard by the employee could improve the intelligibility of the signal. Better intelligibility enables better order capture. However, it was decided that the testing conducted at our level of development should concern only discrete tests such as the STI, described in the Research portion of this document.

6. Stereo Mixer: The motivation for including a mixer initially stemmed from the interest in adding white noise to the mix. A mixer adds significant expandability to the system, allowing multiple signals to be mixed together or panned to different stereo channels.
7. Graphic Equalizer: This device enables simple control over the tone quality of incoming sound. Various designs were researched, including one that used a single chip to control the equalizer. Despite that configuration's simplicity and greater control, it was not chosen due to poor availability of the chip. An alternate and also simple design was chosen that gave control over three frequency bands.

The stereo mixer and the graphic equalizer were chosen to be included in the current design for the purposes of making the system more robust and easily controlled.

The Speech Gate Controller

A major environmental factor that was considered in the development of the new system is the ambient noise of the facility, such as kitchen noise in a drive-through restaurant. Although the previous system used a headset microphone to reduce the amount of ambient noise picked up, there was still a substantial level of unwanted noise transmitted to the customer. In the interest of reducing feedback and allowing the customer to talk naturally, an etiquette was developed for the intercom. When the customer is talking:

- -There should be no noise transmitted from the speaker next to the customer. This allows the customer to talk naturally, without being interrupted by loud noises. This also reduces feedback to the employee.
- -The employee should be listening, not talking.

To enforce this protocol, an electronic system known as the Speech Gate Controller (SGC) was designed. To save on costs, an inexpensive and highly capable AVR microcontroller was selected. It can be programmed very rapidly and easily. This small computer is used to control an analog switch, which mutes the server's voice (and any ambient sound) when it detects that the customer outside is talking. The algorithm used by the computer is capable of adapting over time to different noise environments, such as nearby car traffic, wind, or low-volume music coming out of a customer's car. Also included is an override switch to disable speech gating if it is needed. This could be useful when a customer is playing very loud music that is indistinguishable (by the system) from acceptable sound.

The microcontroller module is intended to be expandable, and is configured to be readily reprogrammed if needed. It is also capable of controlling multiple devices, such as a white noise generator in the future, if it is pursued.

Component Selection

The scope of this semester's work included creating an entirely new kiosk. The preamplifier designs from last semester were modified, so different parts were selected. Many basic electronic components such as resistors and capacitors were bought in bulk to save money, and also to keep replacement parts available in case of a hardware failure. After all the device schematics were finalized, the necessary components were put into a list, and finally budgeted for in a spreadsheet.

Table 1 presents an excerpt from one stage of the electronic component ordering process.

Shure Microphone Preamp					
Part	Description	Price	Quantity	P*Q	Supplier
71-CMF551K0000BHEB	1/8W .1% 1k resistor	\$0.36	8	\$2.88	Mouser
71-RN60C-B-20K/R	1/8W .1% 20k resistor	\$0.34	8	\$2.72	Mouser
71-CMF5510K000BEEB	1/8W .1% 10k resistor	\$0.52	12	\$6.24	Mouser
660-MF1/4DCT52R1500F	¼ 1% 150 resistor	\$0.05	12	\$0.60	Mouser
594-5073NW200R0J	200 ohm 5%	\$0.16	4	\$0.64	Mouser
594-5073NW820R0J	820 ohm 5%	\$0.16	4	\$0.64	Mouser
660-MF1/4LCT52R222J	2.2k 5%	\$0.05	4	\$0.20	Mouser
71-CMF075K0000JNEK	5k 5%	\$0.18	2	\$0.36	Mouser

Table 1: Excerpt from Preamplifier Budgeting Spreadsheet.

After the prices were obtained for the components from Digi-Key and Mouser, the budget was sent to the Purchasing team for processing and ordering. Next, power requirements by the devices were considered. There are two main differences in the power requirements from last semester. One is that we were informed by Shure the phantom power supply (standard 48V) did not require more than 15V. The other difference is that power had to be provided for all components including the class D amplifiers. After reading datasheets and speaking with a representative from Astrodyne, it was decided best to use two power supplies for each chassis. There PS-45C was chosen for bipolar low current and the PS 65-15 was chosen for the higher current requirements of the class D. This may have been unnecessary. During lab testing of the system, the class D was never seen to draw more than 25mA. However, it is good practice in research to follow the recommendations of the datasheet.

Circuit Prototyping

The only new devices integrated into the intercom system were the stereo mixer and the graphic equalizer. Before developing a printed circuit board (PCB) layout, the schematic designs needed to be physically verified. The stereo mixer was constructed on a breadboard in a manner identical to the design. When connected to the pre-existing intercom system, there was no signal distortion noticed. It also demonstrated correct functionality in “panning” the sound from the left channel to the right channel.

The graphic equalizer originally used a BA3812L Tone Balancing chip to modify the signal, shown in Figure 1. However, when the circuit was built on a breadboard and tested, it produced significant distortion in the output signal, making it unusable. It was discarded in favor of a simpler design, Fig. 2, that used widely available operational amplifiers and basic electronic components to achieve three-band equalization. In testing, it succeeded in providing highly effective adjustment of frequency response.

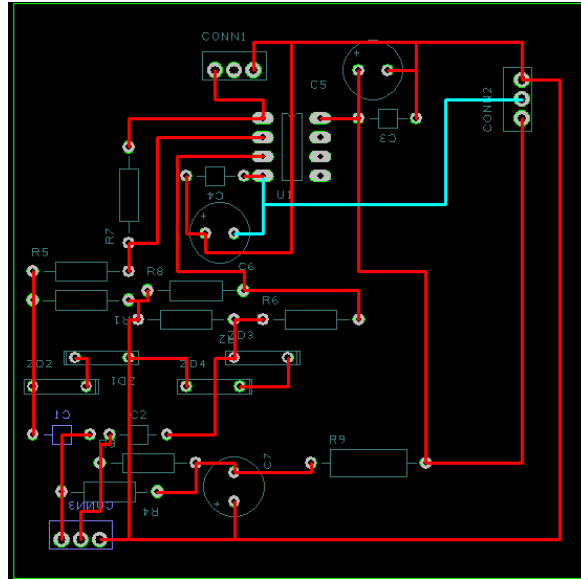

Figure 5: 2nd Revision of Shure Preamplifier PCB

Circuit Board Assembly

After the arrival of the circuit boards from Advanced Circuits, the Circuits and Signal Processing Team was organized to populate the boards. This involved soldering the previously purchased components to the board and verifying that no physical damage was incurred in the process. The placed components were also verified against both the original schematics and the PCB layouts. Over two sessions, the preamplifiers, the mixer, and the equalizer were successfully constructed.

Module-Level Assembly

Further improvements to the appearance and accessibility of the electronic devices was achieved by mounting them with stand-offs inside specialized enclosures. There were two enclosures purchased and used: one for the SSM, and the second for the CSM. The enclosures were perforated on the sides to promote heat dissipation and improve the longevity of the components. The SSM benefited greatly from this enclosure. It is very simple to operate, using labeled knobs for volume and tone adjustment. Circuit-level modifications can be made by removing the top of each enclosure and unscrewing each board. The internal connections have been simplified to facilitate maintenance on separate modules.

9. Obstacles

There were many obstacles that the members of IPRO 344 had to overcome during the course of the semester. Time was always a factor in the completion of the group's goals. The creation and design of a new kiosk was a major obstacle early in the semester but the kiosk modification team with the help of other group members designed a built a brand new kiosk quickly and in time for the new electronics to be installed. The circuit and signal processing team had to deal with the creation of a new budget because of the new electronic hardware that was being created and duplicated. Again time was an issue for this team and the long distance parts were shipped posed a hurdle they had to deal with. Because the team wanted to improve the testing methods for the equipment brand new testing methods had to be developed and implemented into qualitative and quantitative results, as well as finding proper equipment, software and acoustically viable lab space proved to be problematic.

10. Conclusions

IPRO 344 was able to complete a large amount of work this semester. We built a new kiosk that is more modular and easier to test. In addition, we replicated all of the existing electronics, making improvements as we went, and added a client priority gate, a mixer circuit, and an equalizer. Finally, we developed a testing protocol, and performed some preliminary tests on both the old and the new systems. Here are some preliminary conclusions that can be drawn from the testing data we were able to take.

- Cardioid Microphones tend to perform better than Omnidirectional Microphones
- Placing the microphone deeper within the cavity produces a higher intelligibility
- Acoustic foam increases the intelligibility of the system

11. Recommendations

The IPRO 344 team would like to expand the Drive-Through Audio Analysis to include more robust time frequency plots, the ability to perform all calibration steps for testing, and the ability to output SII measurements.

1. Perform extensive testing of the old and new systems. Use the testing methods we developed, with several trials, to obtain more accurate values for the speech transmission index. Perform statistical tests on all the variables to determine if there was a statistically significant change in intelligibility.
2. Investigate noise filters to eliminate or at least lessen the effect of external audible noise. Use the frequency analysis software we developed to determine the frequency bands which should be eliminated.
3. Perform intelligibility tests with human subjects to validate the mechanical results. This may have to wait until next spring at least.
4. Investigate speech detection and recognition software.
5. Coordinate with a McDonalds or other fast food franchise to use our testing protocol on their system. If we can get this, we will have quantitative data on existing systems and can directly compare our system to existing ones.

12. References

- [1] ANSI S 3.5 1997 *Methods for Calculation of the Speech Intelligibility Index* Acoustical Society of America 1997 American National Standards Institute
- [2] True RTA Software *True Audio, INC*
www.trueaudio.com
LexSTI Software by Matt Bakke
<http://www.hearingresearch.org/STIinfo2.htm>
- [3] “Voice frequency” Wikipedia contributors. *Wikipedia, The Free Encyclopedia*.
24 April 2009 03:46 UTC
http://en.wikipedia.org/w/index.php?title=Voice_frequency&oldid=275547941
- [4] *SPP2 Speaker Post Installation Instructions* HME, Inc et al. © 2003 HM Electronics, Inc
- [5] “Hold The Pickle I and II” Markowitz, Judith. *Speech Technology* © 2007–2009 - Speech Technology Media
www.speechtechnologymag.com

13. Acknowledgements

The IPRO 344 team would like to thank Dr Ralph Muehleisen for his advice and guidance on acoustical testing as well as the loaning of testing equipment. The 344 team would also like to acknowledge and thank Shure Inc, for the generous donation of microphones for the project.

