

# IPRO 335

## Alumni Memorial Hall Renovation

### Architecture Team

Bradley Ford	Architect of Record
Youjoung Kim	Architect
Hyunjoo Oh	Architect
Rebekah Reid	Project Funding Coordinator
Nathaniel Woods	Architect

### Civil Engineer Team

Alek Babel	Structural Engineer of Record
Dan Dow	Structural Engineer
Syed Kazi	Structural Engineer
Matt Helland	Structural Engineer
Jared Szajkowski	Structural Engineer
Prince Tambah	Structural Engineer

### Architectural Engineer Team

Matt Gibbs	Architectural Engineer of Record
Tamakia Edwards	Architectural Engineer
Jeffrey Uecke	Architectural Engineer
Steve Uecke	Architectural Engineer
Celeste Wegrzyn	Mechanical Engineer
Tania Atanassova	Architectural Engineer

# Historic Status

- The entire campus is a National Historic Landmark, as listed by the National Park Service
- University wants to treat every building as an individual National Landmark
- Follow STANDARDS set by the city of Chicago and guidelines set by the NPS
- University is eligible for funding from federal and local governments and multiple corporations
- Renovations can occur but can not effect the overall look or interior of the building - any changes must be clearly discernable

# Current Design

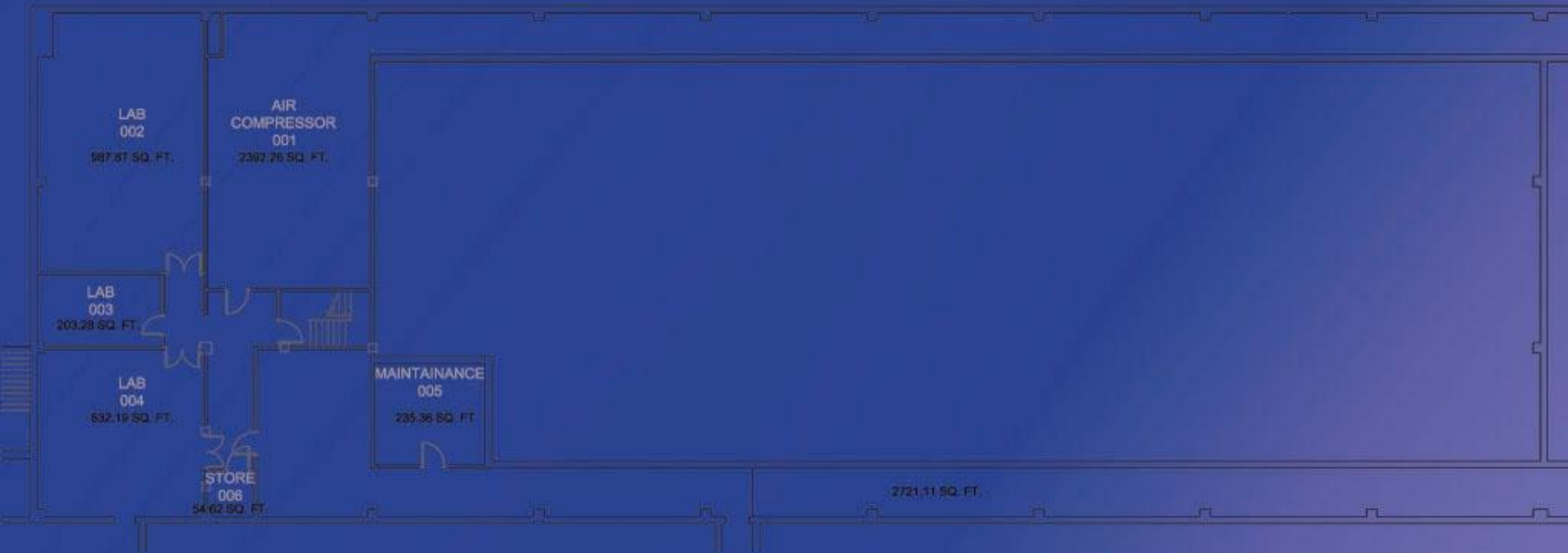

Basement Floor

# Current Design

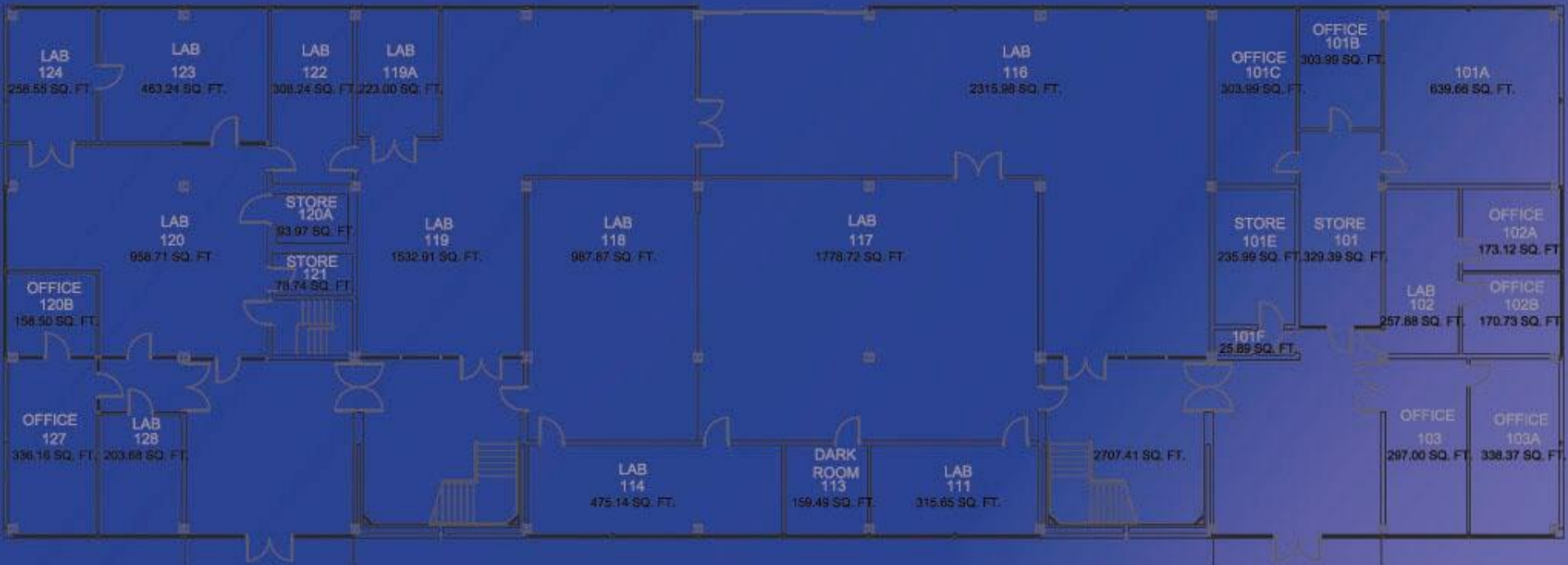

First Floor

# Current Design

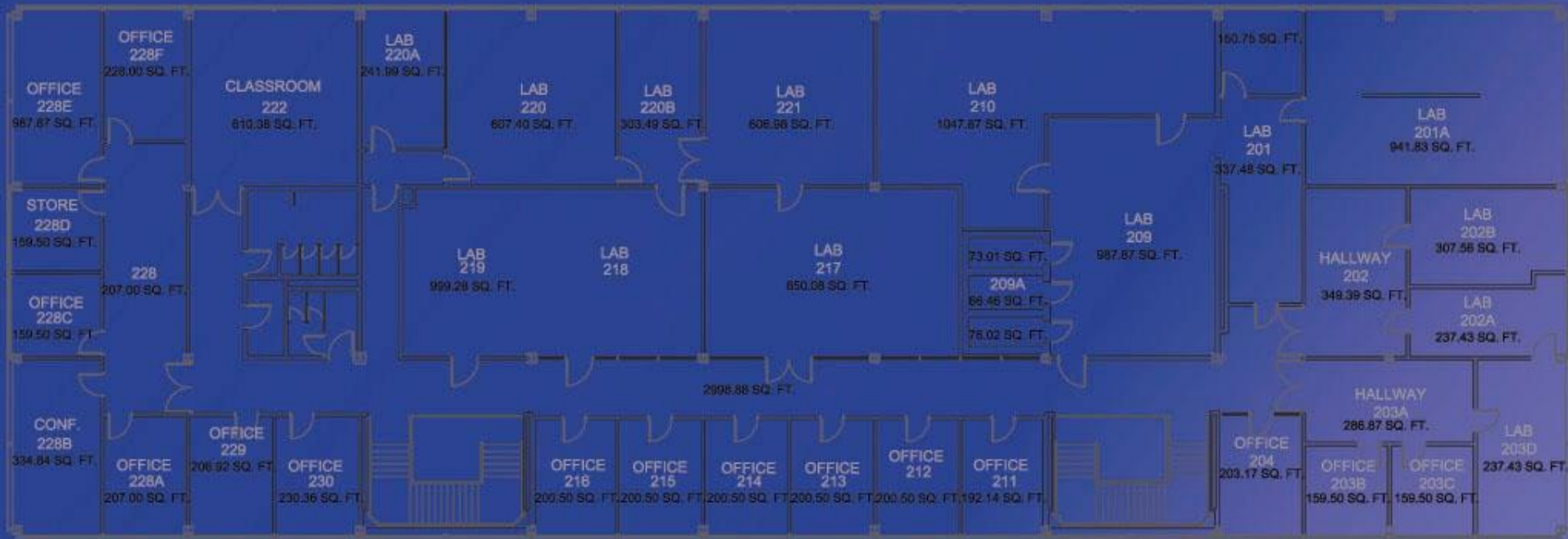

Second Floor

# Current Design



Longitudinal Section (looking south)

# Current Design

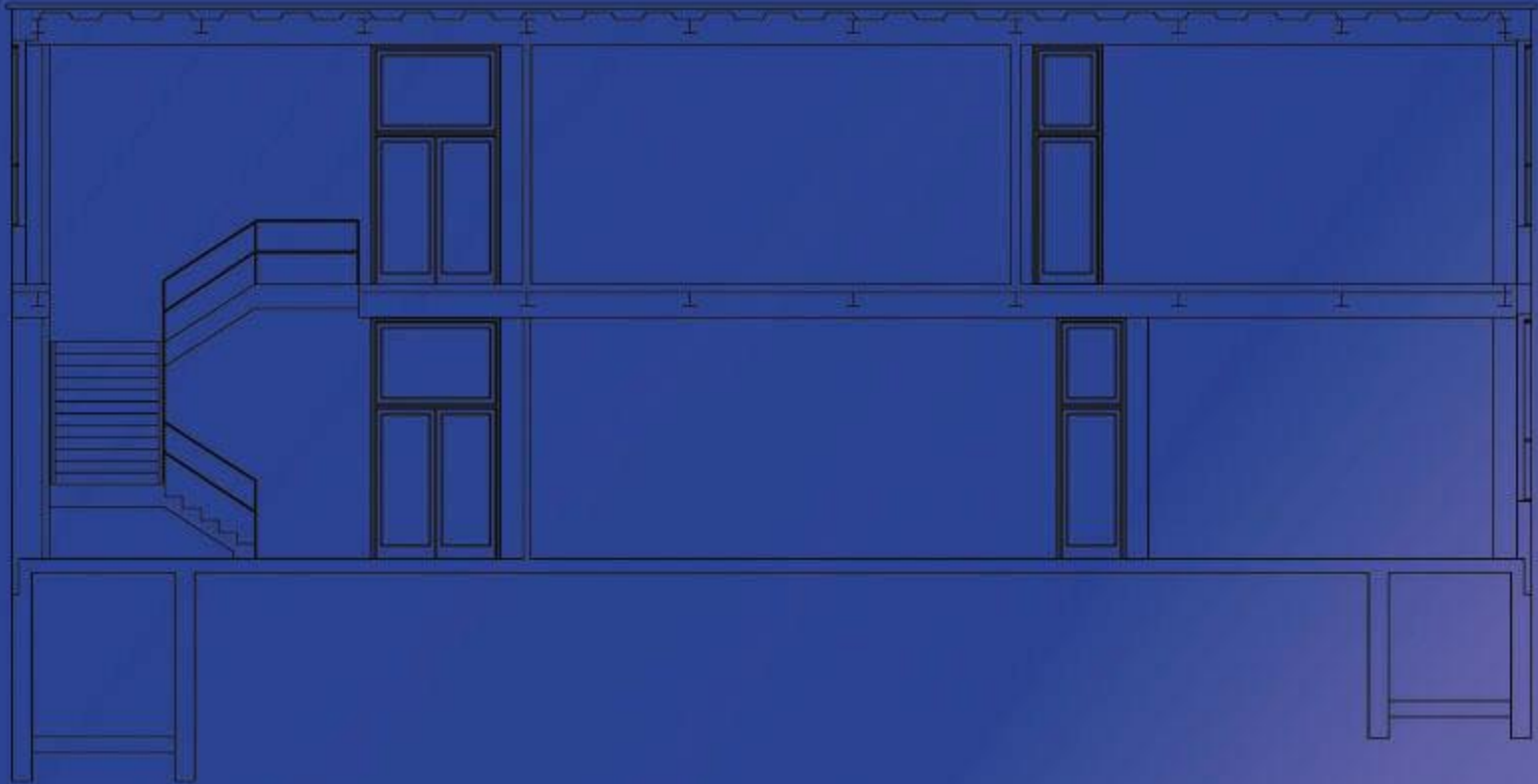

Transverse Section (looking west)



# Energy Model

- Used Revit MEP 2008 to create 3D model of Alumni Hall by drawing in 3D over the floor plans of the current layout.
- This program came out on April 13, 2007. This newest technology is mostly focused on new buildings to determine their energy usage and modify it before plans are finalized.

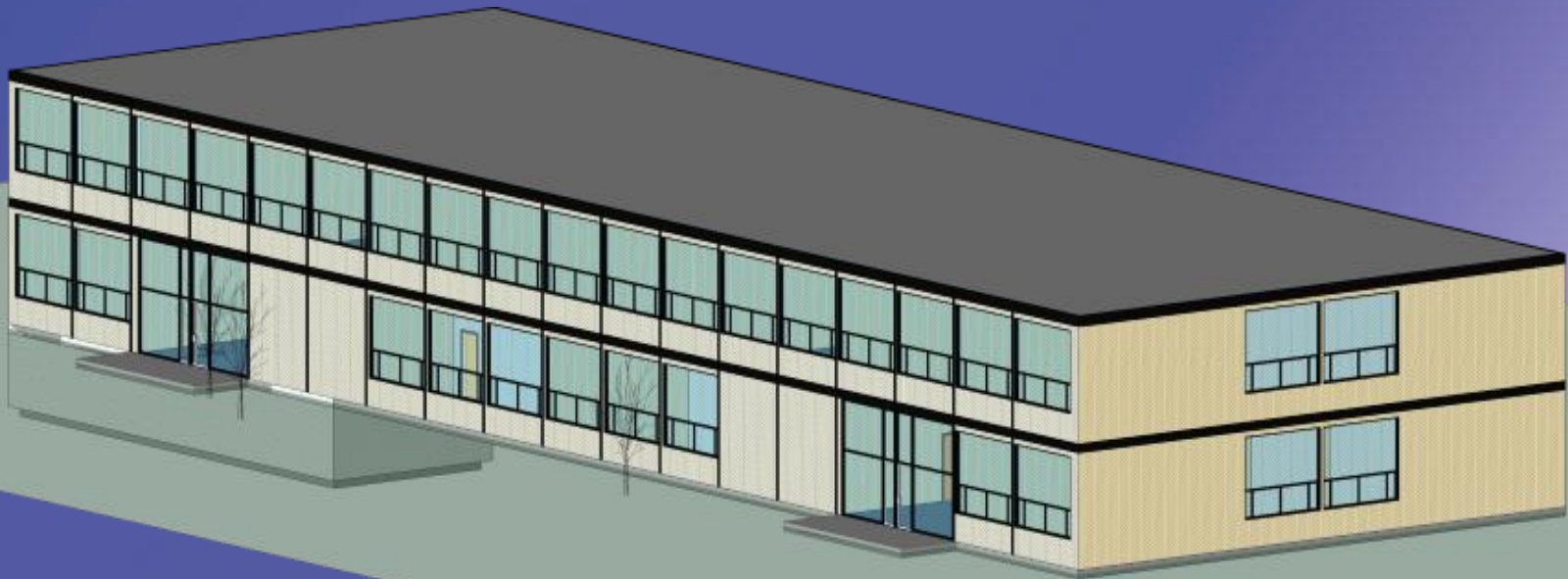



# Energy Model

- Used Revit MEP 2008 energy analysis package (by IES) to calculate energy usage through their virtual environment. This analysis run is based on an average year from weather data gathered at O'Hare Airport.
- This was done and the input numbers adjusted to come out to values similar in magnitude to the actual energy usage recorded by facilities.



- The following are charts based on the actual conditions in Alumni Hall, the Model created in Revit MEP 2008, and the proposed improvement of simply upgrading the windows to thermal pane.

# Current Energy Usage

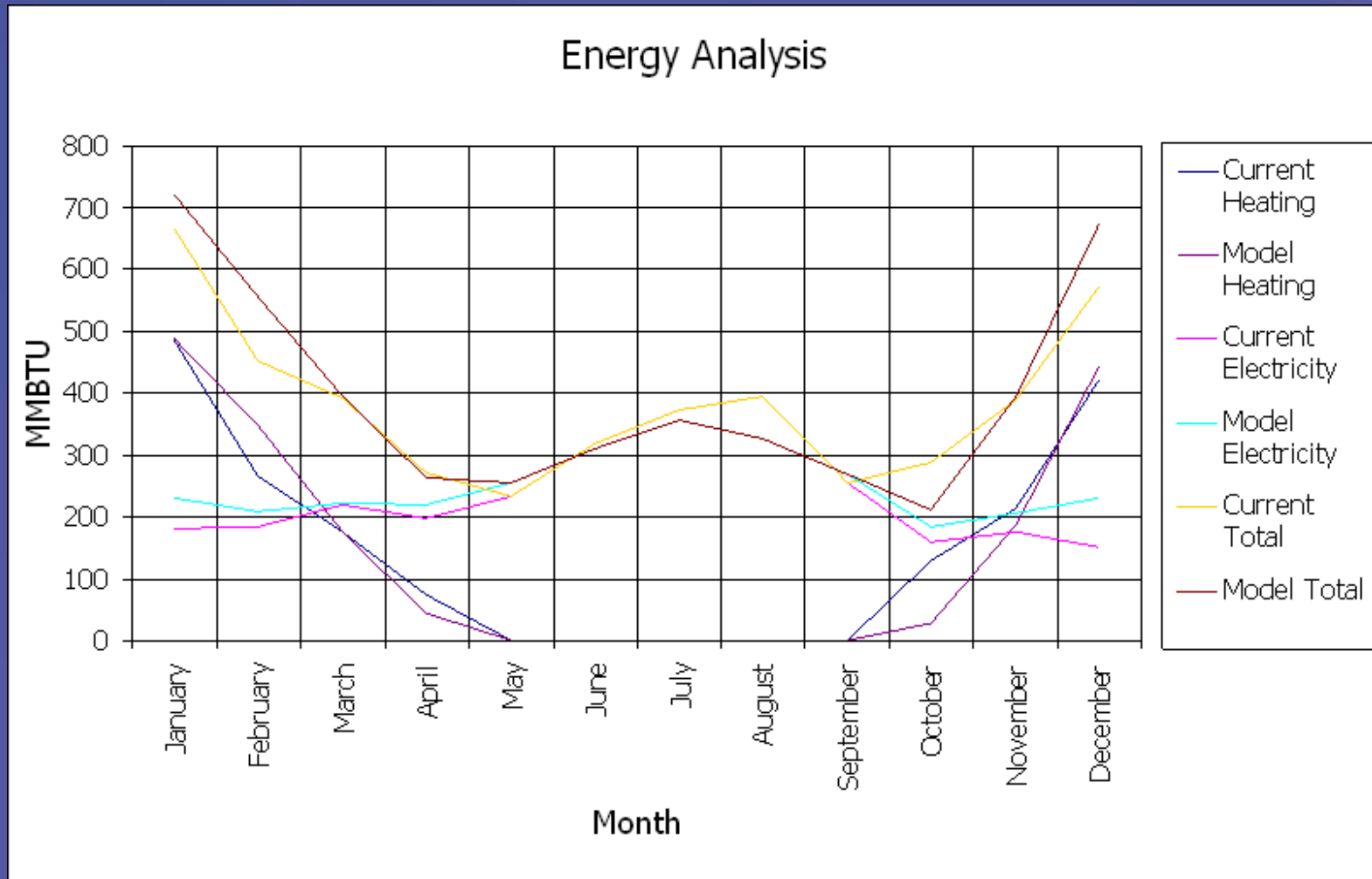

# Proposed Energy Usage

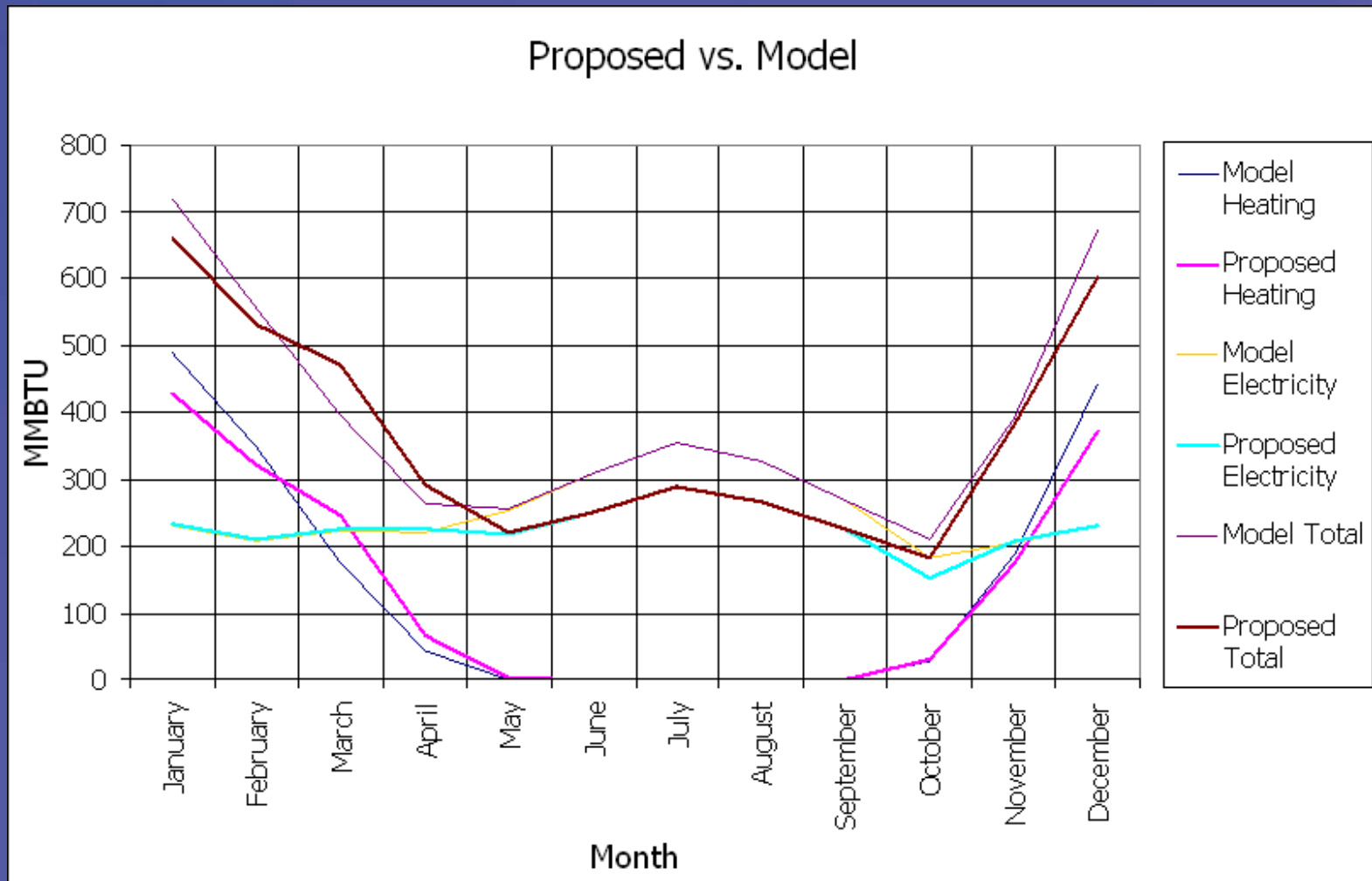

# Energy Usage

- Model is reasonably close to actual conditions (within 2.7%)
- Found that thermal glass might lower energy usage by nearly 7.5%
- Other suggestions:
  - Add more roof insulation
  - Install an efficient HVAC system for the entire building
  - Seal/fix rusting window frames to reduce infiltration
  - Coat the roof with a light color of rubberized roofing material
  - Insulate Steam pipes that run through the basement.

# Some Problems and Solutions Involving Current HVAC System

- Problem A: Poor indoor air quality symptoms which could result without proper ventilation system include the following: irritated eyes, nose and throat, upper respiratory infections, nausea, dizziness, headaches and fatigue, or sleepiness—have collectively been referred to as “sick building syndrome”.
- Solution A: Fit environment with air handling systems and controls that deliver more adequate supplies of fresh air but also help dilute or remove contaminants

# Some Problems and Solutions Involving Current HVAC System

- Problem B: Temperature and humidity affect occupants, due to the lack of a controlled system the current Alumni Building is inconsistent in regard to temperature. This is a problem because of the possibility of the presence of mold and bacteria when humidity levels are greater than 72%. When this is the case studies found more complaints of allergy symptoms associated with sick building syndrome. OVERALL student performance at mental tasks is affected by UNCOMFORTABLE changes in temperature.
- Solution B: Per OSHA, regulations require that between fifteen and twenty cubic feet of air per minute per person is circulated. There are enhancements in ventilation systems that allow system to switch into a low energy mode when room is unoccupied . The system can also be controlled centrally therefore the entire building can be easily and quickly switched into a “vacation mode” to save energy during holidays and vacations. The system can interface with lights and other devices to optimize energy use as well.



# HVAC System – Existing

- Current system delivers steam to each room for heating
  - Radiators are very hot – potential safety hazard
  - Controls are very minimal – if it's too hot the windows are opened



# HVAC System – Existing

- Central air conditioning is piecemeal
  - Only available in parts of building
  - Several systems
  - Controls are primitive
- Other rooms may be air conditioned by ugly, noisy, and inefficient window units
- No way to control or condition fresh air supply to rooms



# HVAC System – Proposed

- Combine all current systems into a centralized variable air volume system
  - Efficient
  - Quiet
  - Provides a method of conditioning and distributing fresh air
  - Cooling can be provided by campus chilled water plant

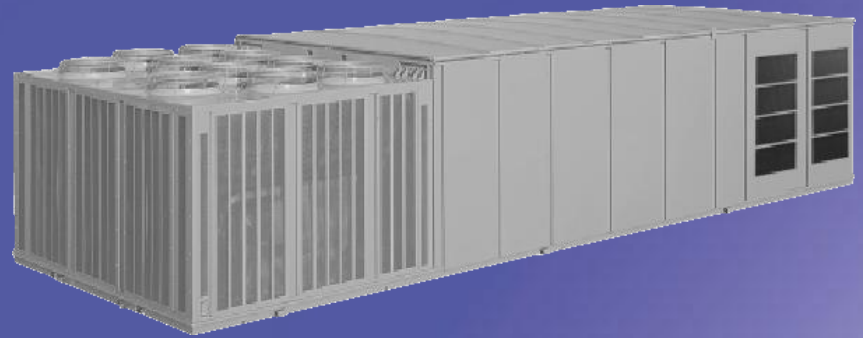

# HVAC System – Proposed

- Integrate control system into a building management system
  - Switches into a low energy mode when room is unoccupied
  - Can be controlled centrally – entire building can be easily and quickly switched into a “vacation mode” to save energy during holidays and vacations
  - Can interface with lights and other devices to optimize energy use



# Lighting

- Existing system was recently upgraded with new energy efficient fixtures
- Fixtures should be re-usable
- New control system
  - Will detect occupancy and natural light and adjust accordingly
  - Will integrate into building control system to provide central control
  - Can also control window shades if desired

# Lighting

- Illumination measurements taken in typical labs, offices, and classrooms during a typical afternoon.
- Horizontal illuminance at book level.
- IESNA recommended level of illumination for reading is 50 – 75fc therefore lighting is sufficient.
- Labs 218 and 220B are computer labs hence lower illuminance levels are acceptable. The measurement of 26fc is based only on daylight so true illuminance values may vary.

First Floor		
Room	Rm #	Ave. Illuminance [fc]
Lab	119A	78
Lab	119	129
Stairway	22	60
Office	101B	76
Lobby	1000	206
Second Floor		
Room	Rm #	Ave. Illuminance [fc]
Office	228E	78
Room	228B	71
Classroom	222	80
Main Hallway	2000	92
Stairway East	158	103
Stairway West	166	73
Lab	220B	26
Lab	218	49



# Electrical

- **Current system is a combination of original system and upgrades**
  - Everything works; appears to meet codes
  - Has been upgraded as needed
  - Some components don't work well with modern equipment
  - Components in random places all over building
  - Did not contemplate computers and audio/visual equipment
- **Upgraded system**
  - Panels will be centrally located in small closets that open into the hallways for more convenient servicing
  - Will be designed to handle modern equipment and provide more receptacles in rooms

# Plumbing

- **Current system is mostly original**
  - Does not feature water saving fixtures
  - Heat exchangers are old and not designed to be very efficient
  - Some pipes have been clogged with corrosion
  - Not ADA compliant
- **New system**
  - Refurbish original fixtures and install water saving devices when possible
  - Replace pipes and heat exchangers
  - Add ADA compliant fixtures



# Structural Tasks

- Investigate existing structural systems
- Investigate current loads and load combinations
- Structural analysis of existing main structural system
- Design of retrofits, if necessary

# Existing Structural System

- Alumni Memorial is a steel structure, with cast in place concrete floors. There is a basement under part of the structure, and the steel framing rests on the foundation walls and spread footings.
- It was difficult to accurately determine the extent to which beam to column connections transfer moment, and how much shear the brick walls in the building resist. To be conservative, it was assumed that the connections transfer no moment, and the walls resist no shear.
- Steel yield strength is 36ksi, and compressive strength of concrete is 3ksi. Reinforcing steel was assumed to have 40ksi yield strength.

# Current Loads and Combinations

- It was determined that should Alumni Memorial have a third floor added, that the current Chicago Building Code would govern the entire structure.
- Current minimum loads:
  - Classrooms: 40psf
  - Offices: 40psf
  - Labs: 100psf

# Structural Analysis

- Steel Framing
- Soil Bearing
- Footing Strength
- Floor capacity



# Steel Framing

- A model of the steel framing was constructed in SAP2000.
- Current CBC loads were applied to the existing structure, and a load simulating a possible third floor was added.
- Critical members in the framing were columns, as their loads would increase under an additional floor load.
- Preliminary analysis shows that framing is adequate for extra load in terms of strength. Additional analysis of the structure, mainly connections, is required to check for buckling.

Z  
Y X

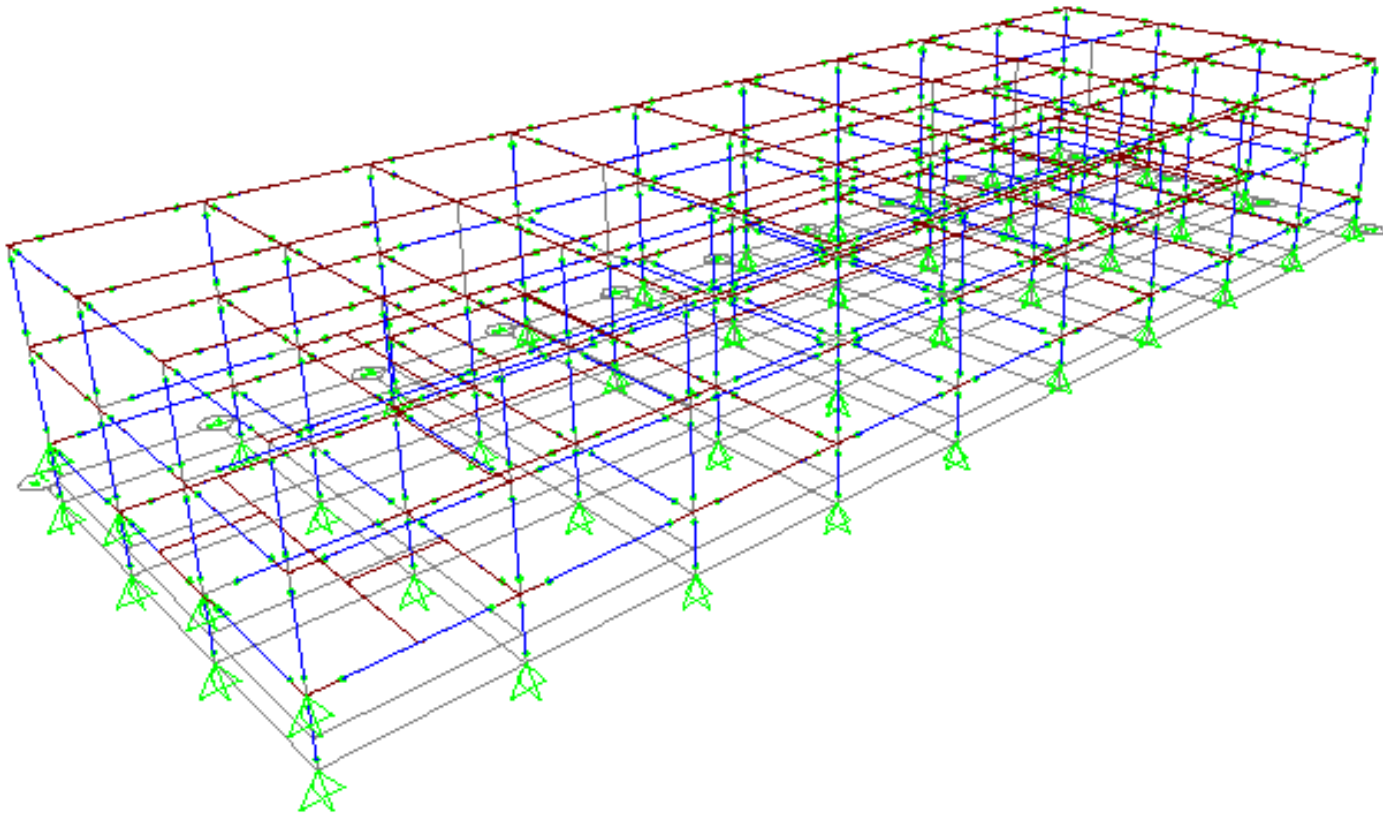

Z  
Y X

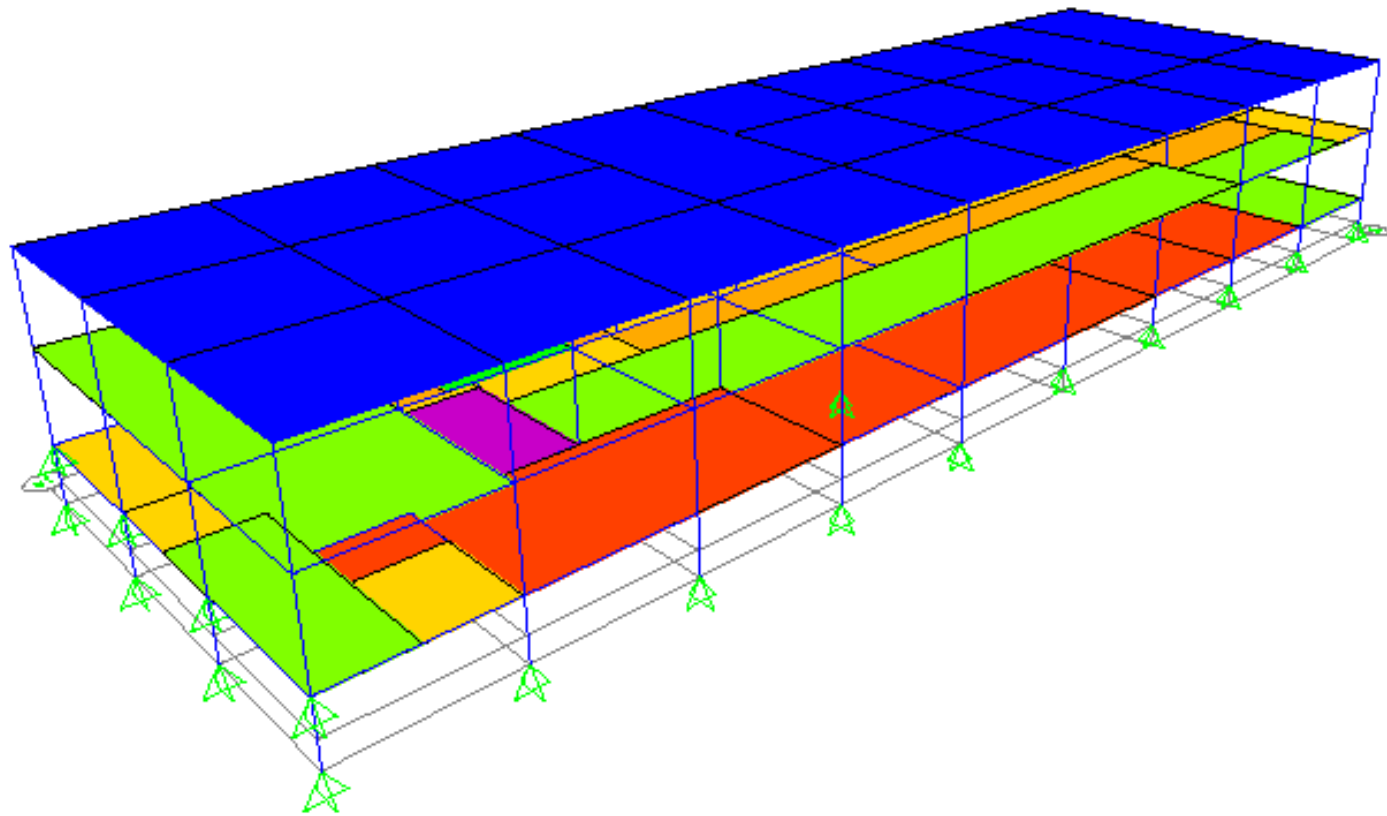

-125. -115. -106. -96. -87. -77. -67. -58. -48. -38. -29. -19. -10. 0.

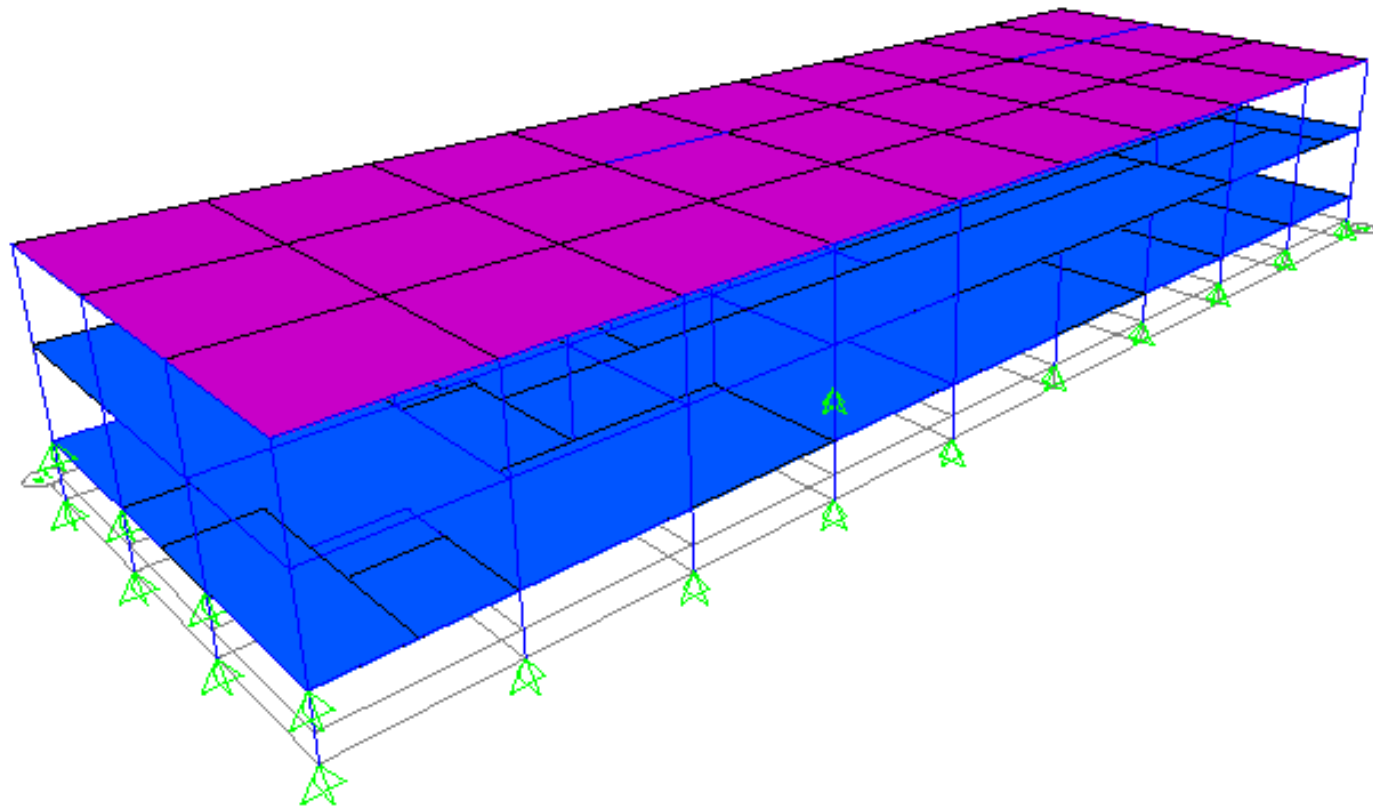

-25.0 -23.1 -21.2 -19.2 -17.3 -15.4 -13.5 -11.5 -9.6 -7.7 -5.8 -3.8 -1.9 0.0



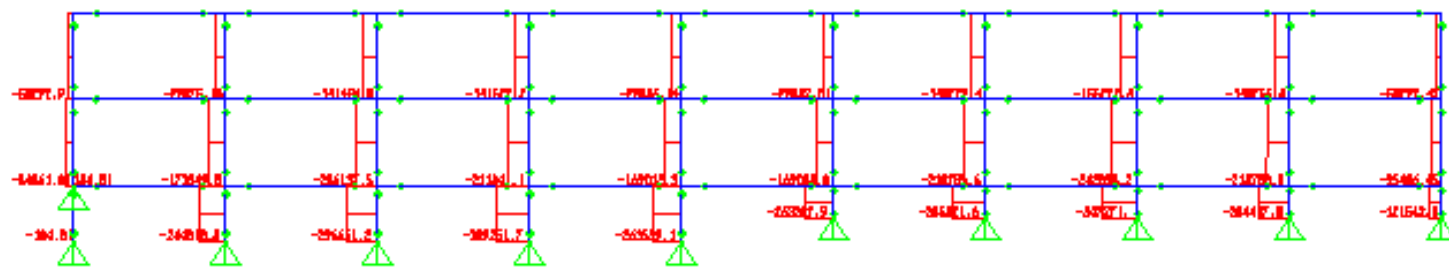

# Soil Bearing

- There is no soil report for the area surrounding Alumni Memorial Hall. The team used a report from the construction of MTCC to estimate the allowable stress. The geotechnical report for MTCC suggested an allowable bearing stress of 3000psi.
- Based on analysis, the soil is strong enough for bearing for the current loading, and an additional floor of load.

Syed Kazi						
I PRO 335						
<b>Soil Strength Verification</b>						
	Design Bearing Pressure:	3000	psf			
	Concrete Unit Weight:	150	pcf			
Foundation	Side Length	Area	Depth	P-load-allow	P-actual-max	% Free
	Feet	Feet <sup>2</sup>	Feet	Kips	Kips	Kips
A	3.00	9.00	1.50	24.98		100.00
B	4.00	16.00	1.67	44.00		100.00
C	6.00	36.00	1.50	99.90		100.00
D	7.00	49.00	1.50	135.98		100.00
E	7.50	56.25	1.50	156.09		100.00
F	8.00	64.00	1.67	176.00		100.00
G	9.00	81.00	1.83	220.73		100.00
H	10.00	100.00	2.00	270.00		100.00
*All footings have square dimensions for length/width						
*Use service loadings when comparing with column F, allowable load						
*Concrete self-weight was accounted for in allowable loading						
*No fill was calculated for since foundations are placed right below basement slab						
* "P-actual-max" column to be filled in with values from sap analysis						
* "% Free" column will calculate left over remaining strength with respect to allowable strength						
<b>Load Breakdown Chart</b>						
Foundation	DL	LL	Total			
	Kips	Kips	Kips			
A	0.00	0.00	0.00			
B	0.00	0.00	0.00			
C	0.00	0.00	0.00			
D	0.00	0.00	0.00			
E	0.00	0.00	0.00			
F	0.00	0.00	0.00			
G	0.00	0.00	0.00			
H	0.00	0.00	0.00			

# Footing Strength

- In addition to soil bearing, the footings were checked for their ultimate strength.
- Factored loads are used for footing strength, as opposed to service loads for soil bearing.
- Checking the largest footings showed that the footings are adequate for strength, however, they do not meet current ACI requirements for minimum steel area.



0.0) Mathcad Unit Definition Declarations

$$\text{kip} := 1000\text{lb} \quad \text{ksi} := 1000 \frac{\text{lb}}{\text{in}^2} \quad \text{psi} := \frac{\text{lb}}{\text{in}^2} \quad \text{psf} := \frac{\text{lb}}{\text{ft}^2} \quad \text{pcf} := \frac{\text{lb}}{\text{ft}^3} \quad \text{ksf} := 1000 \frac{\text{lb}}{\text{ft}^2}$$

0.1) Explanation

In order to check the foundations in a timely and efficient manner, the checks will start with the largest foundation sizes. These will be carrying the larger loadings the the structure transmits to the the foundation and will be more susceptible to failure due to increased loading of planned renovation.

1.0) Check Footing "H"1.1) Footing Specifications

$$L := 10\text{ft} \quad W := 10\text{ft} \quad D := 2\text{ft} \quad w_c := 150\text{pcf} \quad f_c := 3\text{ksi} \quad f_y := 40\text{ksi}$$

$$A := L \cdot W \quad A = 100 \text{ft}^2$$

$$s_{\text{cover}} := 3\text{in} \quad \text{concrete cover spacing}$$

$$d_{\text{bar}} := \frac{5}{8}\text{in} \quad \#5 \text{ bar is used}$$

$$n_{\text{bars}} := 27 \quad A_{\text{bar}} := d_{\text{bar}}^2 \cdot \frac{1}{4} \pi \quad A_{\text{bar}} = 0.307 \text{in}^2$$

$$d_t := D - s_{\text{cover}} - d_{\text{bar}} \cdot \frac{1}{2} \quad d_t = 20.688 \text{in}$$

$$A_s := n_{\text{bars}} \cdot A_{\text{bar}} \quad A_s = 8.283 \text{in}^2$$

Reinforcement bar spacing that runs in both directions [perpendicular to eachother]

$$s_{\text{bars}} := \frac{L - 2 \cdot s_{\text{cover}}}{n_{\text{bars}}} \quad s_{\text{bars}} = 4.222 \text{in}$$

1.2) Column Specifications & Transferred Loading

$$L_c := 20\text{in} \quad W_c := 20\text{in} \quad A_c := L_c \cdot W_c$$

$$DL := 75\text{kip} \quad LL := 75\text{kip}$$

$$q_{\text{ult}} := \frac{1.2 \cdot DL + 1.6 \cdot LL}{A} \quad q_{\text{ult}} = 2.1 \text{ksf}$$

# Floor Capacity

- To check for new building configurations, the maximum live load allowed on the first and second floors was checked.
- On the first floor, the allowable live load is about 100psf, and 90psf on the second.
- Lab space would need to remain on the first floor, while most any configuration would be acceptable on the second floor.

Slab "B"

8' x 24'

-4 1/2" slab  
-3/8" @ 7" o.c.

$$d = 4.5 - 1 - \frac{1}{2} \left( \frac{3}{8} \right) = 3.3125$$

$$A_s = \rho \cdot l \left( \frac{l}{7} \right) = \underline{0.189 \text{ in}^2/\text{ft}}$$

$$\rho = \frac{A_s}{bd} = \frac{0.189}{(12)(3.3125)} = \underline{0.00475}$$

$$m = 15.69$$

$$\rho = 0.00475 = \frac{1}{15.69} \left( 1 - \sqrt{1 - \frac{2(15.69)R}{40,000}} \right)$$

$$R \Rightarrow 8565 = 1 - \frac{2(15.69)R}{40,000} = \underline{182.9 \text{ psi}} = R$$

$$M_n = Rbd^2 = (182.9)(12)(3.3125^2) \left( \frac{1}{(12)(1000)} \right) = \underline{2.0 \text{ k-ft/ft}}$$

$$M_u = (M_n) \phi = (2.0)(0.9) = \underline{1.8 \text{ k-ft/ft}}$$

$$\text{Worst Case: } M_u = \frac{w_u l_n^2}{10} \quad l_n \approx 8'3''$$

$$w_u = \frac{10(1.8 \text{ k-ft/ft})}{(8.25')^2} = \underline{265 \text{ psf}}$$

$$\text{Slab DL} = \left( \frac{4.5}{12} \right) (150 \text{ pcf}) = 56.25 \text{ psf}$$

$$\text{Assume total DL} = \underline{100 \text{ psf}}$$

$$265 = w_u = 1.2(100) + 1.6 w_{LL}$$

$$\underline{w_{LL} = 91 \text{ psf}}$$

# Design of Retrofits

- Currently, it is not necessary to design retrofits for the structural system.
- We found the current structure adequate for today's CBC loads.
- Should a third floor be added, and column buckling becomes an issue, bracing columns at the top and bottom may be an appropriate solution, as this retrofit can be hidden within walls, not taking away from the character of Alumni Hall

# Summary

- After investigation of the structure, we believe Alumni Memorial would be able to support a third floor. However, some minor modifications may be necessary to strengthen columns.
- If in the future, a third story is built, we would suggest a more thorough analysis of the structure. We suggest material testing, taking a better look at the beam to column connections, and investigating the interaction of the brick walls with the steel structure. These would require destructive exploration, something with which the team is not familiar.

# Architecture Analysis

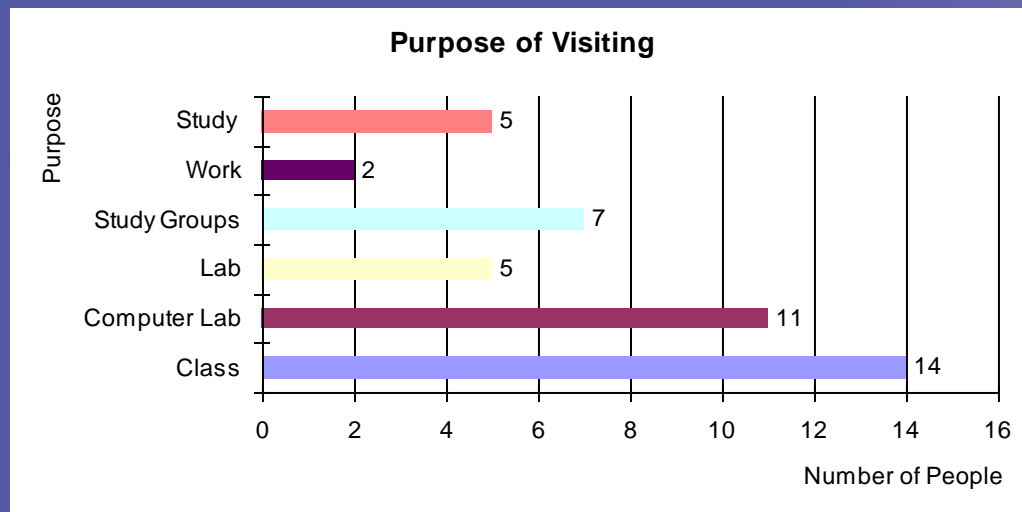
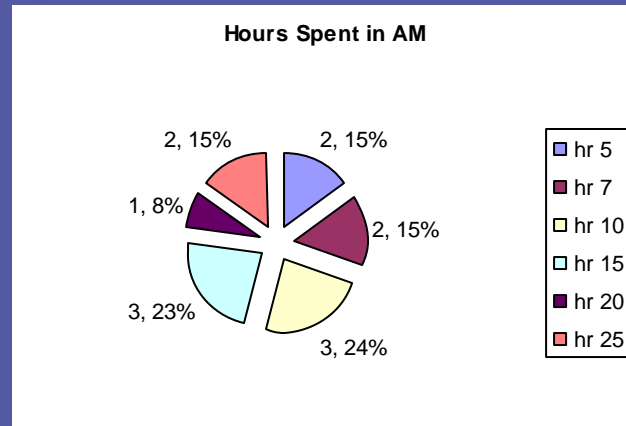
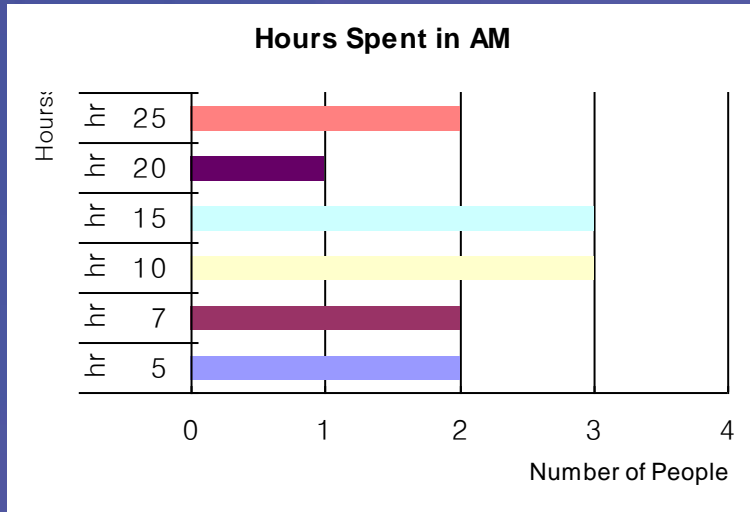

# Architecture Analysis

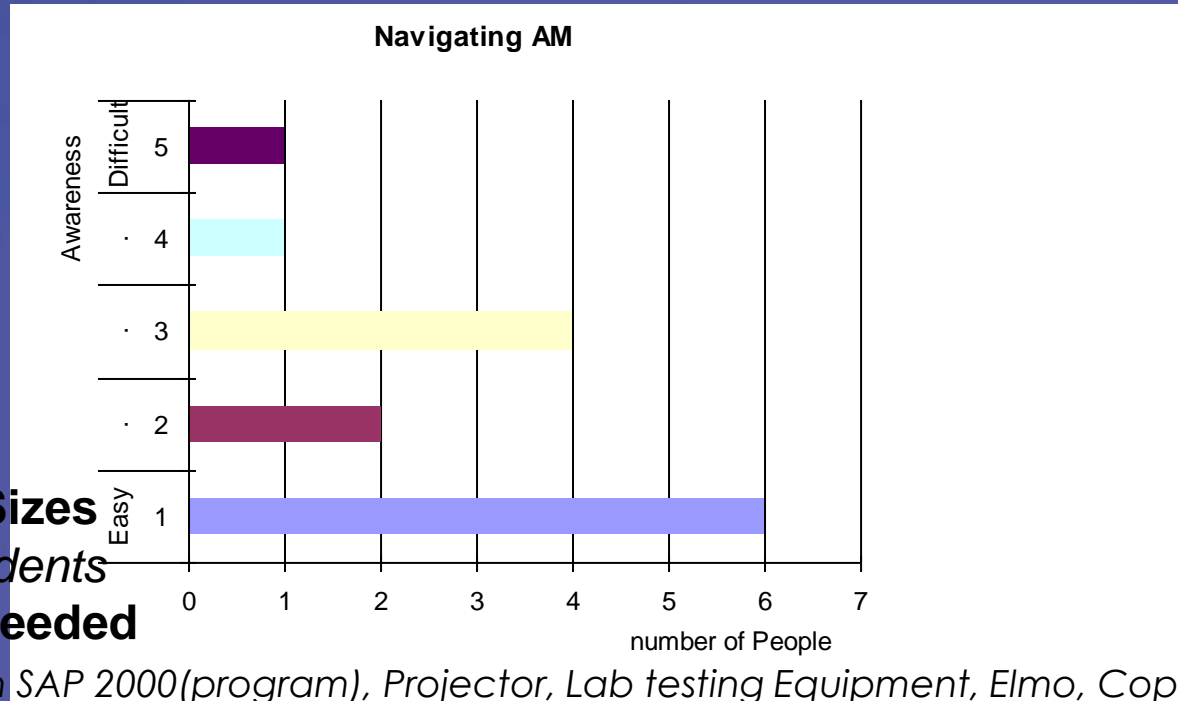

## Most Class Sizes

*20,30-40 students*

## Equipment needed

*Computers with SAP 2000(program), Projector, Lab testing Equipment, Elmo, Copy Machine*

## Students need

*Lab space, Computer lab space, Reference Library, Bigger Classrooms, hydrology lab, good heating and cooling system, another computer lab where has no classes, women's bathroom downstairs, Study Area, Student Study Room, Renovate 221, Student Lounge,*

## Lacking Facility

*Table Space, Work/study area, Tables, Chairs, Hall way on first floor connecting east and west, Bathrooms*

# Architecture Analysis

## **Most Class Sizes**

*20,30-40 students*

## **Equipment needed**

*Computers with SAP 2000(program), Projector, Lab testing Equipment, Elmo, Copy Machine*

## **Students need**

*Lab space, Computer lab space, Reference Library, Bigger Classrooms, hydrology lab, good heating and cooling system, another computer lab where has no classes, women's bathroom downstairs, Study Area, Student Study Room, Renovate 221, Student Lounge,*

## **Lacking Facility**

*Table Space, Work/study area, Tables, Chairs, Hall way on first floor connecting east and west, Bathrooms*



# Proposed Design



Basement Floor

# Proposed Design

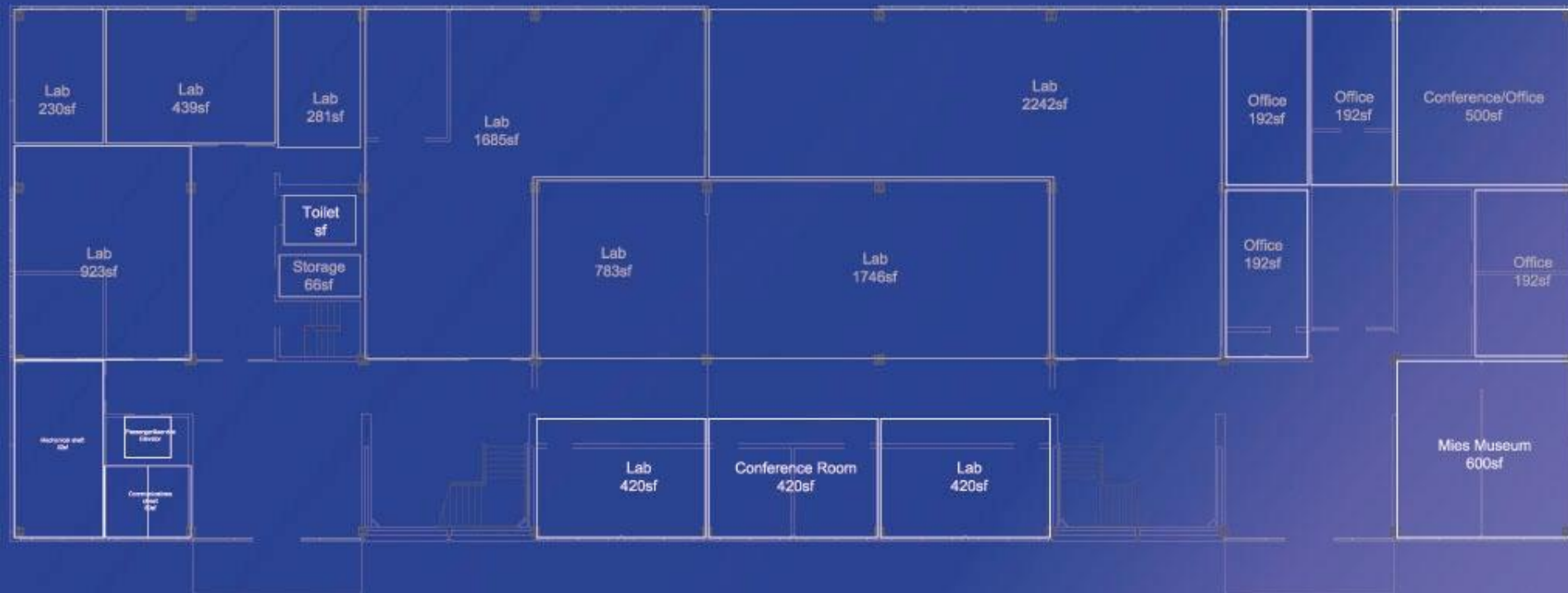

First Floor

# Proposed Design

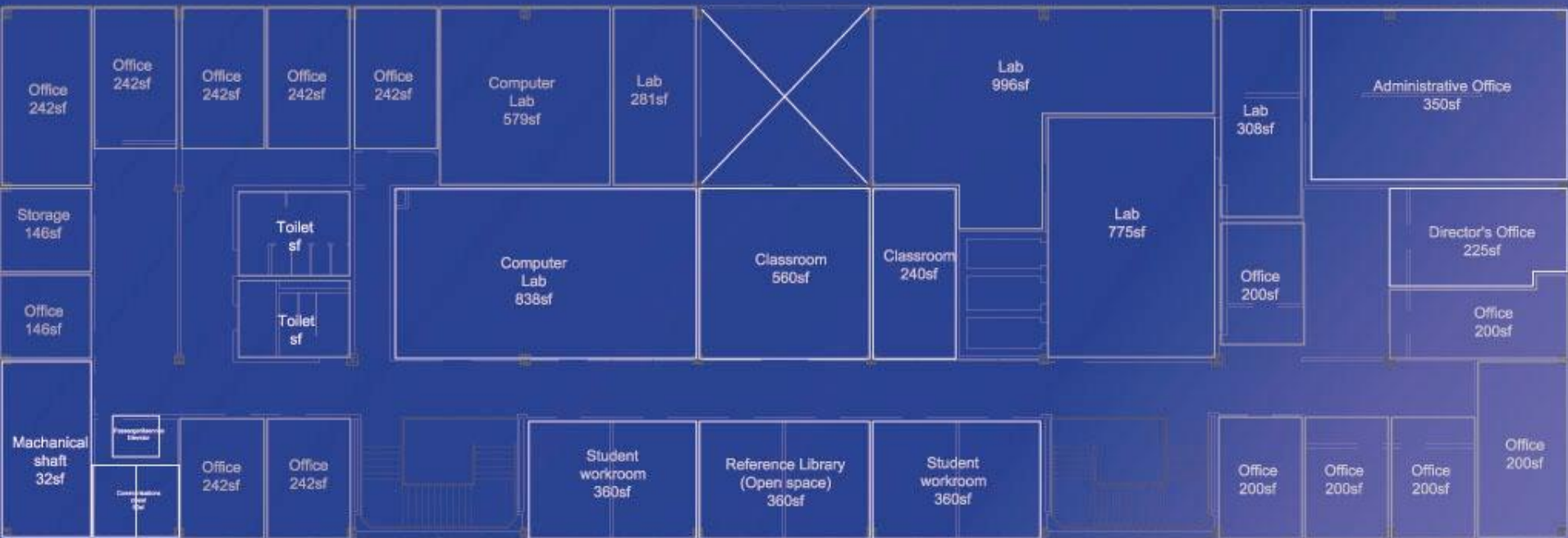

Second Floor

# Cost

## PARAMETRIC ESTIMATE-RENOVATION OF ALUMNI MEMORIAL HALL

Quantity	CSI Number	Description	Crew	Daily Out	Labor Hou	Unit	Bare Mat.	Bare Labor	Bare Equip.	Total	Total Incl. O&P	ZIP Code	Notes
16302	22003401020	Selective	B-16	250	0.128	SF Flr		\$ 58,687.20	\$ 31,136.82	\$ 89,824.02	\$ 125,525.40	606	FIRST FLOOR DEMO
16302	22003401020	Selective	B-16	250	0.128	SF Flr		\$ 58,687.20	\$ 31,136.82	\$ 89,824.02	\$ 125,525.40	606	SECOND FLOOR DEMO
16302	5017210010	SQ FT Cost of Colleges-Science, Enginee				SQ FT	274				\$ 4,466,748.00	606	FIRST FLOOR LAB SPACE
16302	5017190010	SQ FT Cost of Colleges-Classrooms & Ad				SQ FT	184				\$ 2,999,568.00		SECOND FLOOR CLASS AND ADMIN
									<b>TOTAL</b>		\$ 7,717,366.80		
									<b>CONTINGENCY-20% for REN</b>		\$ 1,543,473.36		
									<b>GRAND TOTAL</b>		\$ 9,260,840.16		

# Cost

## PARAMETRIC ESTIMATE-RENOVATION OF ALUMNI MEMORIAL HALL WITH ADDITION OF 3RD FLOOR

Quantity	CSI Number	Description	Crew	Daily Output	Labor Hours	Unit	Bare Mat.	Bare Labor	Bare Equip.	Total	Total Incl. O&P	ZIP Code	Notes
16302	2.2003E+10	Selective B-16		250	0.128	SF Flr		\$ 58,687.20	\$ 31,136.82	\$ 89,824.02	\$ 125,525.40	606	FIRST FLOOR DEMO
16302	2.2003E+10	Selective B-16		250	0.128	SF Flr		\$ 58,687.20	\$ 31,136.82	\$ 89,824.02	\$ 125,525.40	606	SECOND FLOOR DEMO
16302	5017210010	SQ FT Cost of Colleges-Science, Engineer				SQ FT	274				\$ 4,466,748.00	606	FIRST FLOOR LAB SPACE
16302	5017190010	SQ FT Cost of Colleges-Classrooms & Adm				SQ FT	184				\$ 2,999,568.00		SECOND FLOOR CLASS AND ADMIN
16302	5017190010	SQ FT Cost of Colleges-Classrooms & Adm				SQ FT	184				\$ 2,999,568.00		THIRD FLOOR CLASS AND ADMIN
											\$ 10,716,934.80		TOTAL
											\$ 2,143,386.96		CONTINGENCY-20% for REM
											\$ 12,860,321.76		GRAND TOTAL

# Cost

PARAMETRIC ESTIMATE-CONSTRUCTION OF A NEW 3 STORY ALUMNI MEMORIAL HALL													
Quantity	CSI Number	Description	Crew	Daily Output	Labor Hours	Unit	Bare Mat.	Bare Labor	Bare Equip.	Total	Total Incl. O&P	ZIP Code	Notes
16302	5017210010	SQ FT Cost of Colleges-Science, Engineer				SQ FT	274				\$ 7,466,316.00		FIRST FLOOR LAB SPACE
16302	5017190010	SQ FT Cost of Colleges-Classrooms & Administratio					184				\$ 2,999,568.00		SECOND FLOOR CLASS AND ADMIN
16302	5017190010	SQ FT Cost of Colleges-Classrooms & Adr				SQ FT	184				\$ 2,999,568.00		THIRD FLOOR CLASS AND ADMIN
		Size Modifier Factor: 1.1					1.1				\$ 14,811,997.20		
		Location Modifier 606 (CHICAGO)					1.117				\$ 16,545,000.87		
										<b>TOTAL</b>	\$ 16,545,000.87		
										<b>CONTINGENCY-10% for NE</b>	\$ 1,654,500.09		
										<b>GRAND TOTAL</b>	\$ 18,199,500.96		

# Available Funding

- **Alumni Memorial will be treated as a Historic Structure**
- **Can receive Federal Funding and Grant Money**
- **Research thus far conducted through the Community of Science**
- **Many grants available from private corporations**

# Closing

**Thank you for your time today.**

**The IPRO 335 Team**

**Questions, Comments, or Concerns**