

# IPRO 321

Spring  
2008

## Product Development and Testing of Paper Shredder Innovations



THE  
**MANHATTAN**  
— GROUP —

# The Team

## Mechanical

- Stephen Flicek M.E
- Aseem Pandey M.E
- Zachary Capps A.E
- Patrick Bauer A.E

## Electrical

- Vesna Pesik E.E
- Jason Howard E.E
- Sebin Lee E.E
- Matt Anderson C.P.E

## Innovation

- Michael Hatch C.S

# Sponsor Requirements

Paper shredders are:

- Noisy
- Cost sensitive
- Unreliable

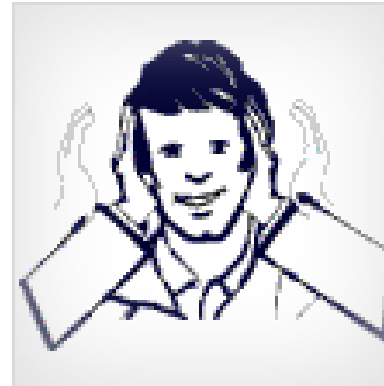

# Three Leading Competitors

- Staples Paper Shredder (\$100)
  - Microcut Shredder Head
  - DC Motor
- Royal Brand Shredder (\$45)
  - Cross Cut
  - AC Motor
- Ativa Paper Shredder (\$120)
  - Diamond Cut
  - DC Motor

# Mechanical

## Objectives

- DETERMINE TORQUE
- OPTIMIZE GEAR TRAIN
- CREATE PROTOTYPE SHREDDER

# Mechanical Testing

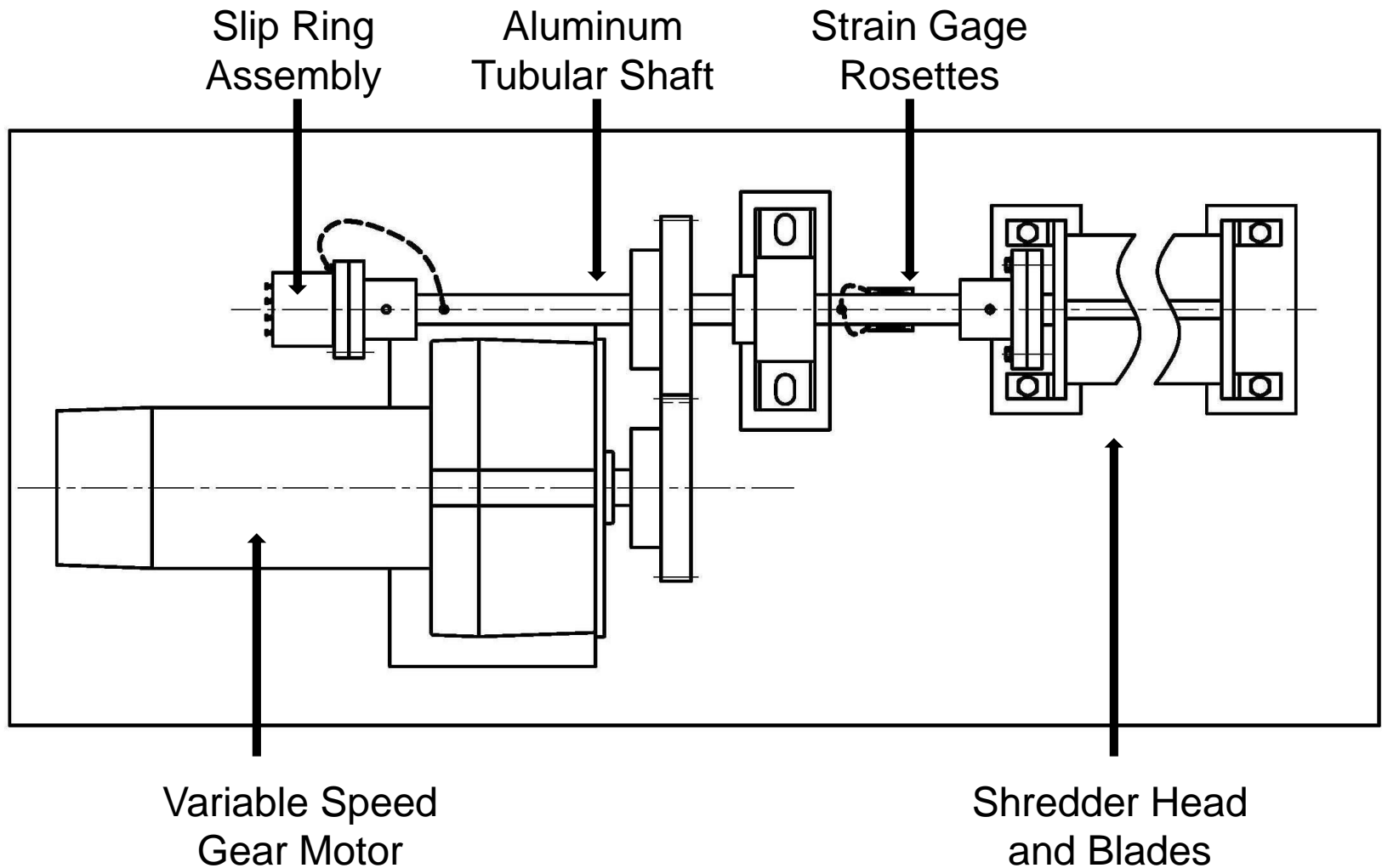

# Torque Data

Torque vs. # of Sheets Shredded

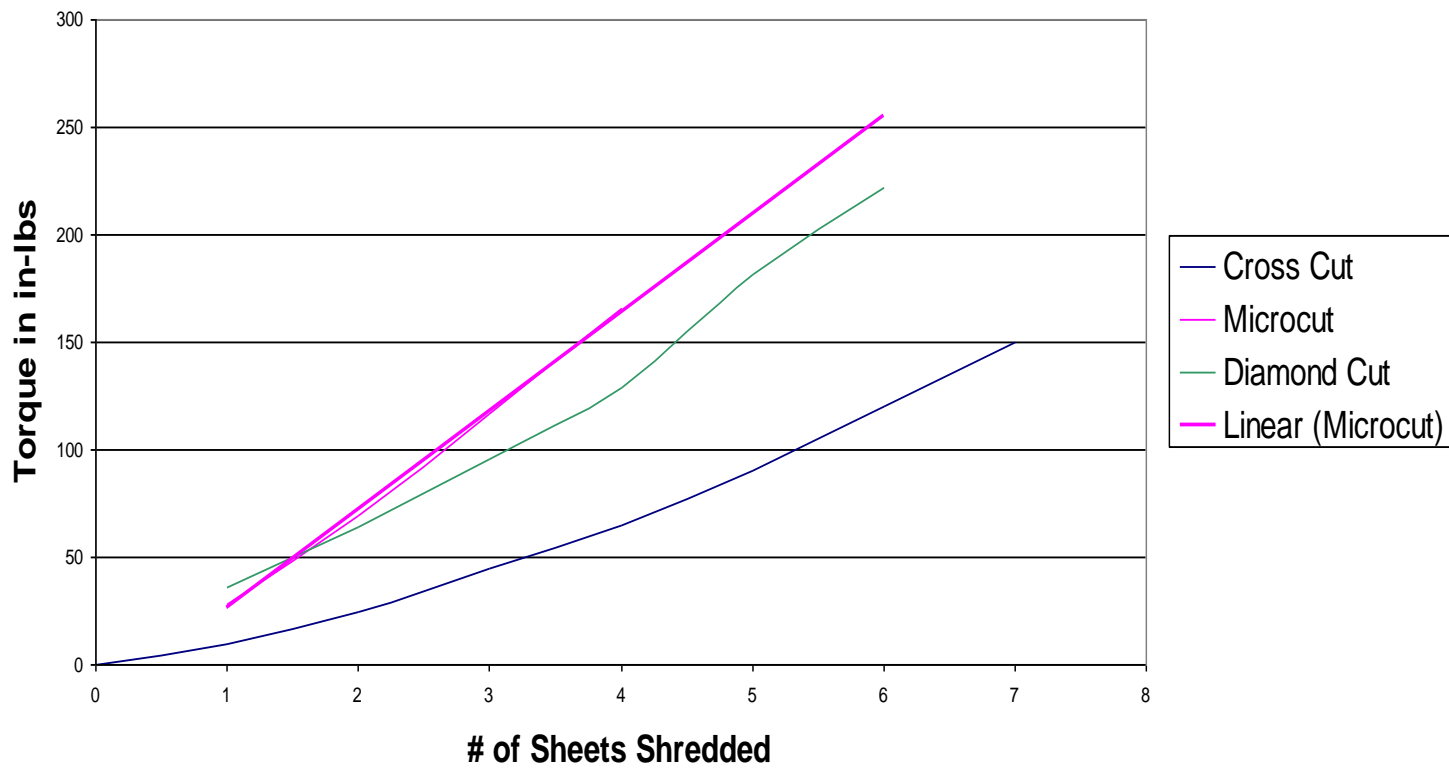

# Application of Torque Data

- Motor and gear sizing
- Creation of new models
- Comparison with competing manufacturers



# Electrical Objectives

- To determine which motor best suits the application and cost requirements
- To determine the horsepower and speed of various motors

# Finding the Best Motor

Tested motors:



DC Motor



Universal Motor

Procedure

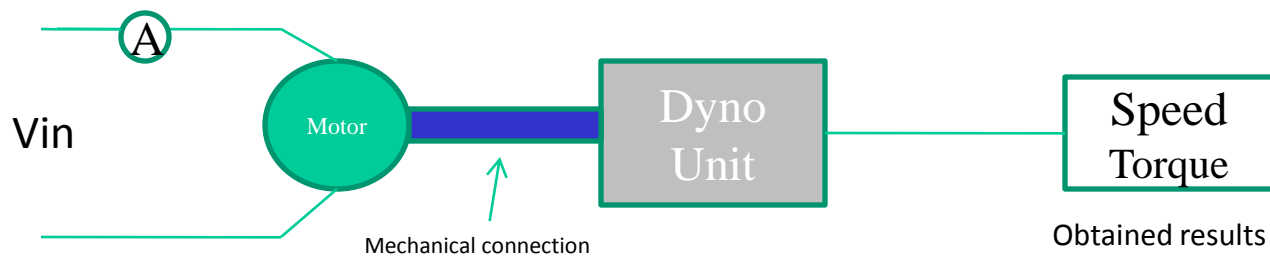

# Motor Test Results



- The DC Motor outperformed the universal motor

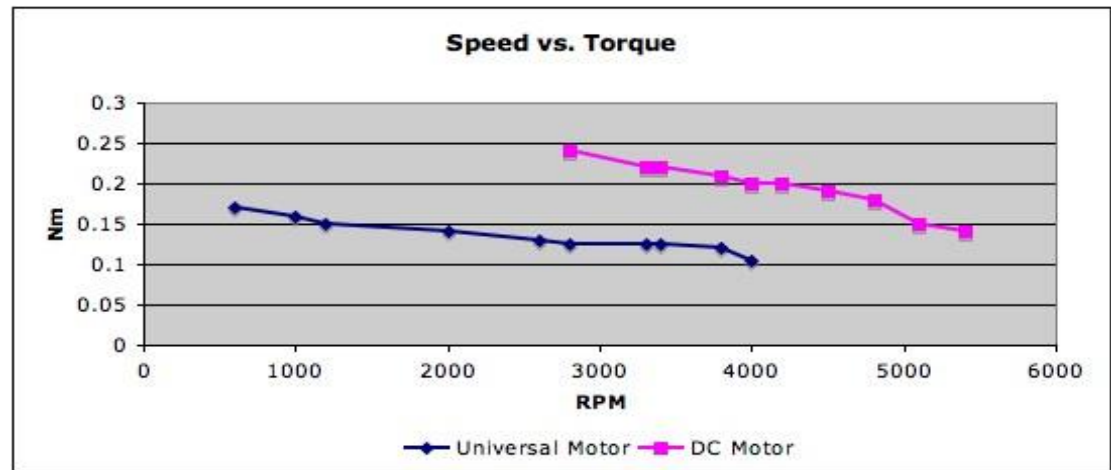

- More horsepower
- More torque
- Higher Speed

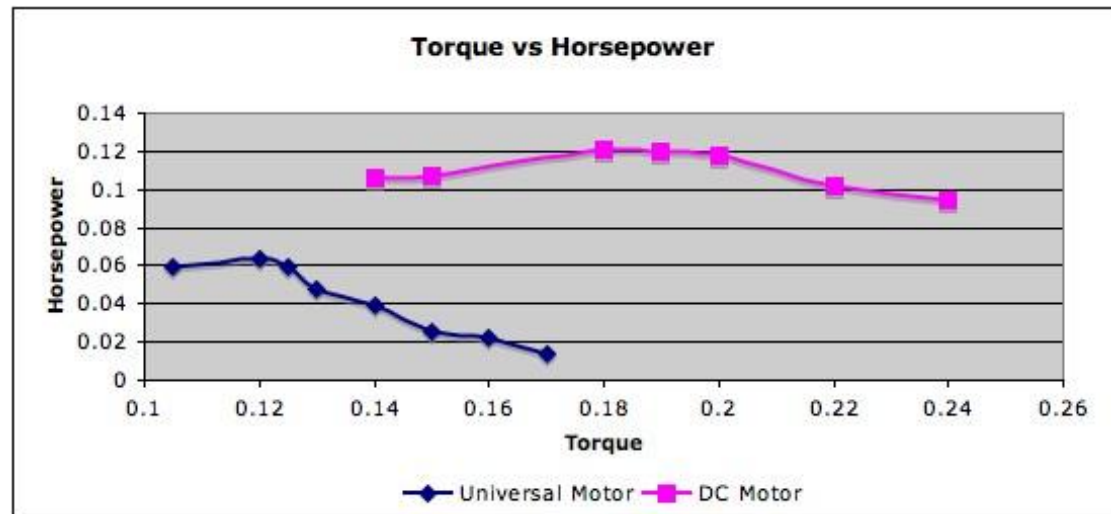

# DC Power is the Solution

- Overall 30% more torque
- DC Motor lasted 25% longer
- AC 120V
- DC 80V
- The motors were run until they stopped

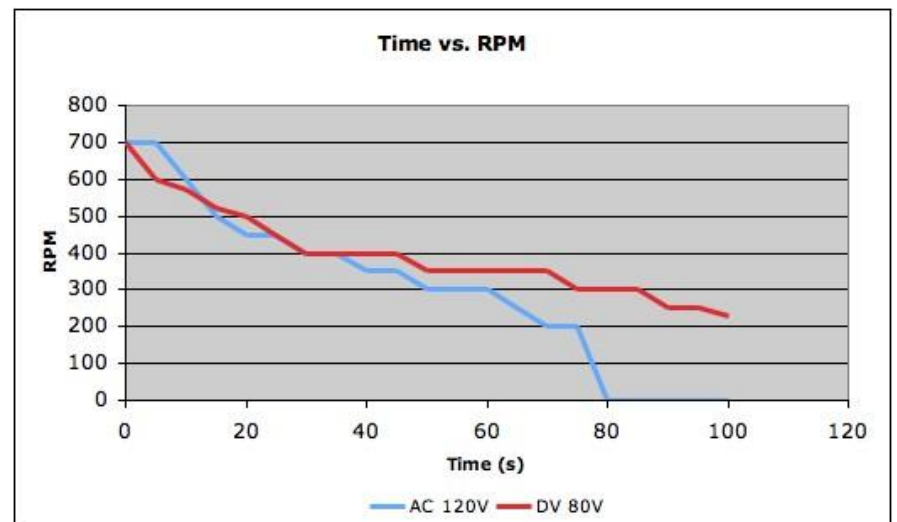
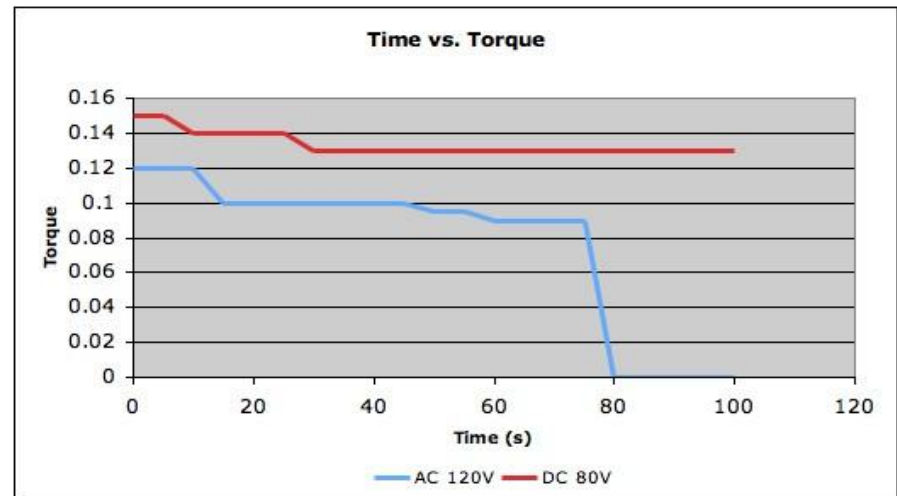

# Prototype Shredder

- Speed Reduction = Torque Increase

- Gear Ratio

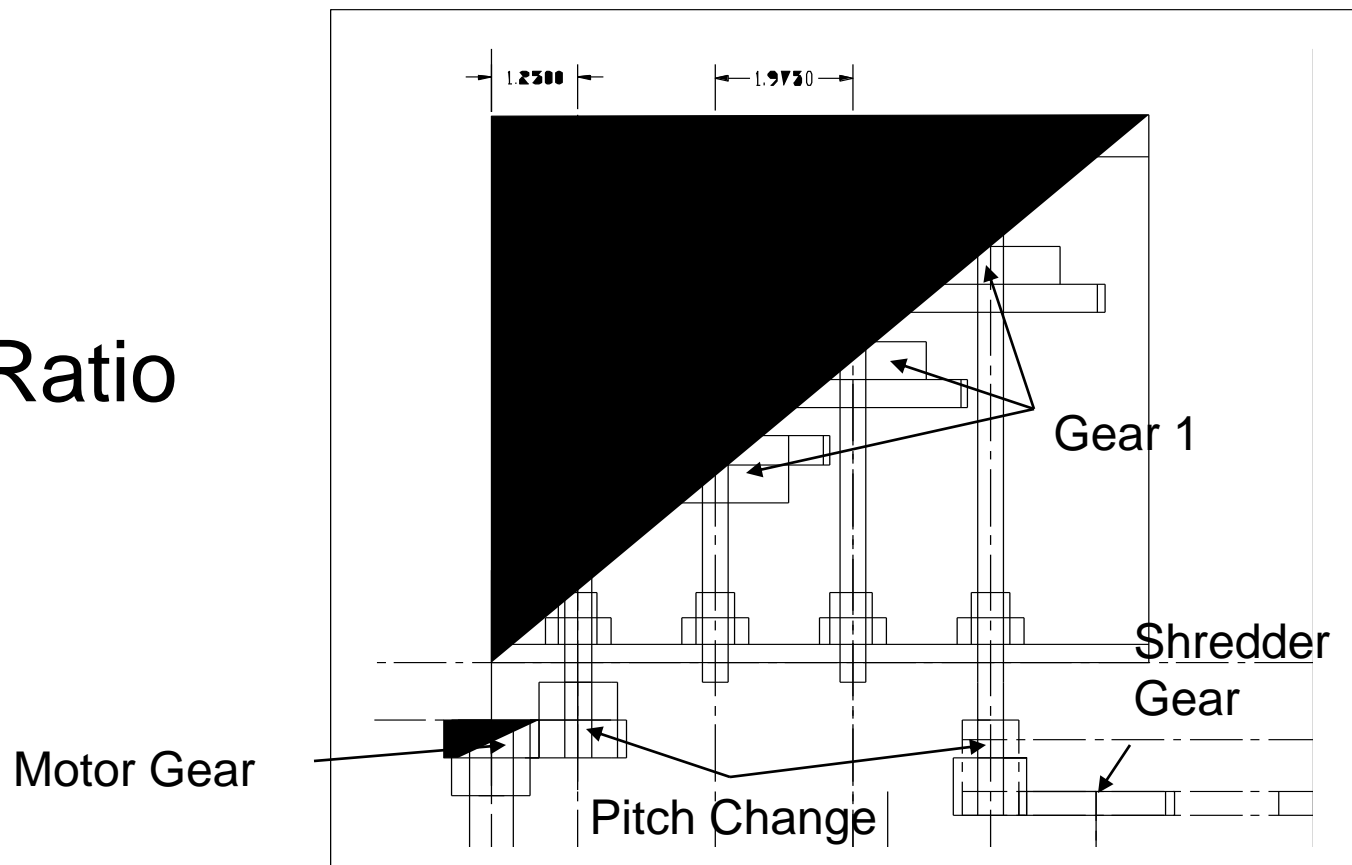

# Alternative Option

## Paper Feeder + Shredder Mechanism

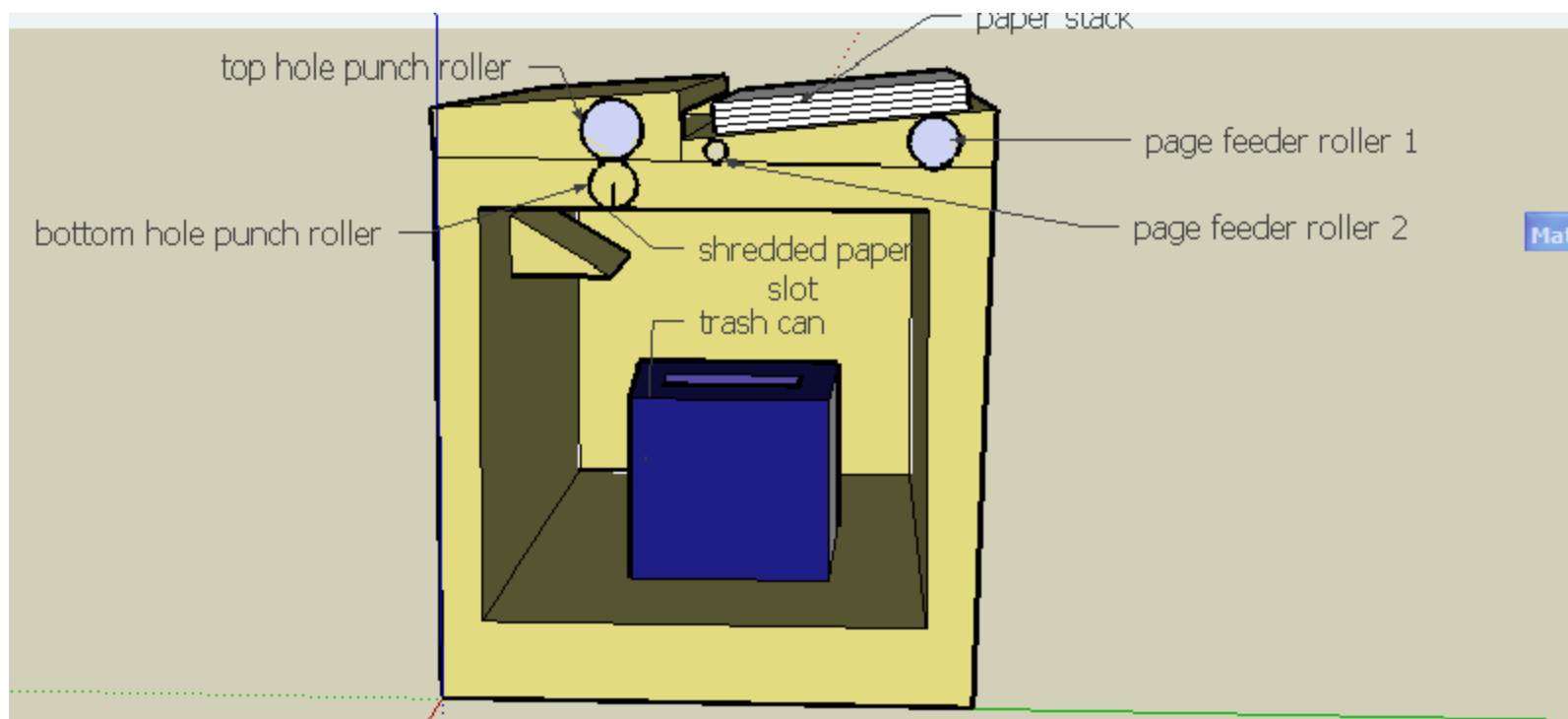

# Concept: Marketability

- Reliability/Durability
- Noise
- Energy Usage
- Speed
- Safety
- Security
- Cost



# Innovate. Rethink. Design.

## Automatic Paper Feeder

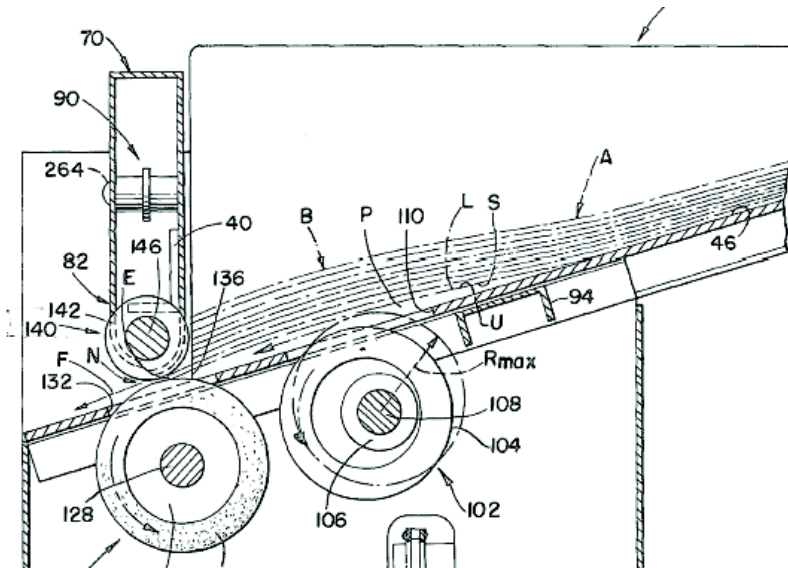

- Self-contained
- Safe
- Fast
- Inexpensive



# Shred vs. Punch

## Shredding Method

- Paper is shred into strip or micro cuts
- Encapsulation

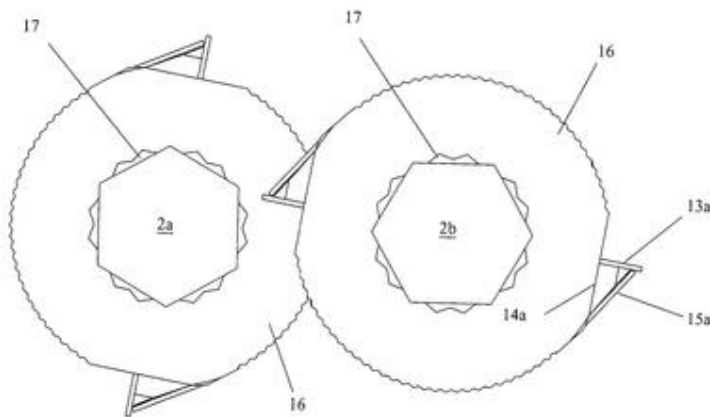

## Punching Method

- Paper is pierced in staggered squares

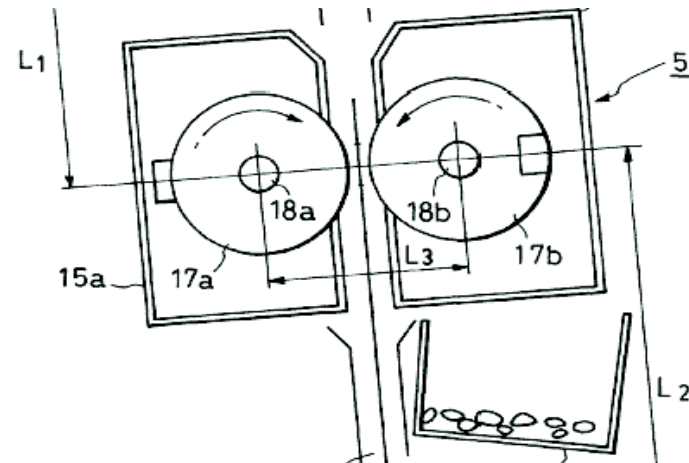

# Recommendations/Res ults

- DC motors are a better value than Universal motors.
- The prototype paper shredder will allow different motors and shredder heads to be tested.
- Coupling a feeder with a simple hole-punching apparatus is new, different, and highly profitable.
- Use non-metallic gears to decrease noise.

# Acknowledgements

- Mr. Seth Lewis, President, The Manhattan Group
- Professor Sheldon Mostovoy
- Mr. Russell Janota, Director, MMAE Laboratories
- IIT Machine Shop
- IPRO Department

# Thank You

