

I PRO 314 - INTERACTIVE URBAN LANDMARK MEMORIAL KIOSKS FOR EQUAL HOUSING RIGHTS



marching for equal housing rights



marquette park 08/05/66

dr. marthin luther king jr. marched through the gage park neighborhood in 1966 to raise awareness about equal housing rights in chicago.

the gage park community is however unaware of the significance of the historical event;

students of gage park high school thus, decided to memorialize this march by designing an interactive memorial for the community.

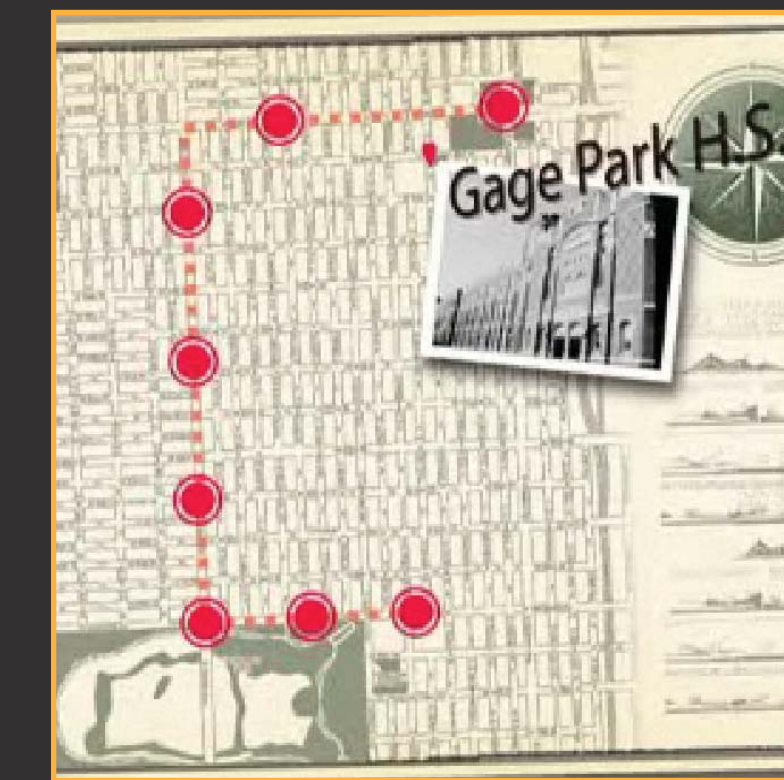

memorial kiosk proposed location



proposed prototype



students proposing their idea @ gage park high school

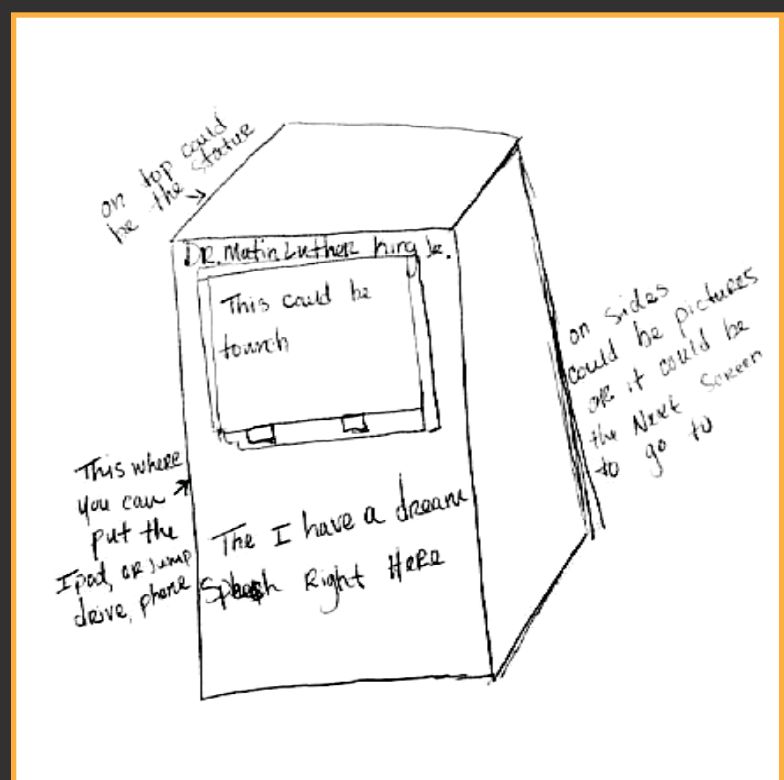

martin luther king booth submitted by danielle

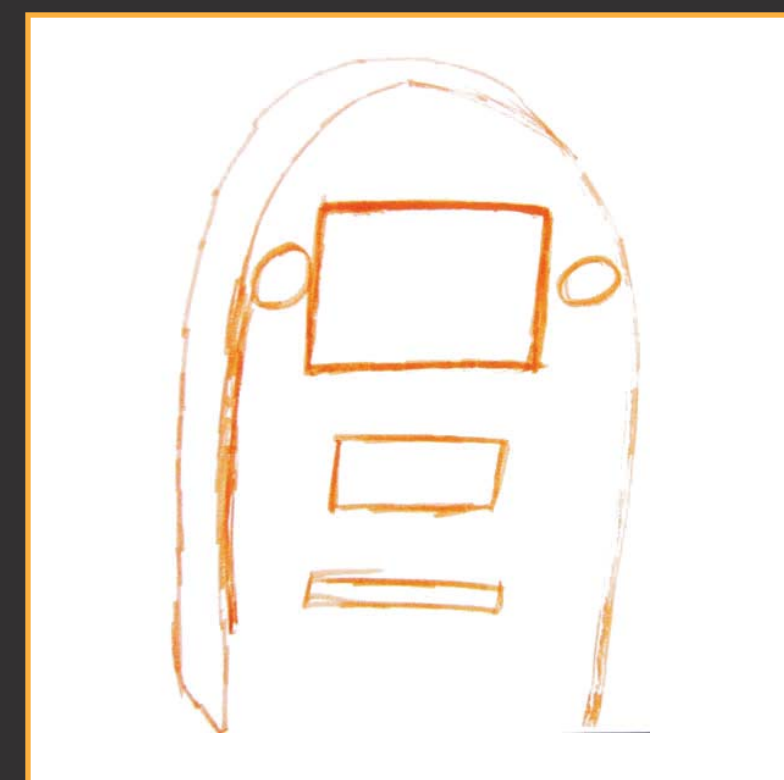

multimedia kiosk submitted by latricia

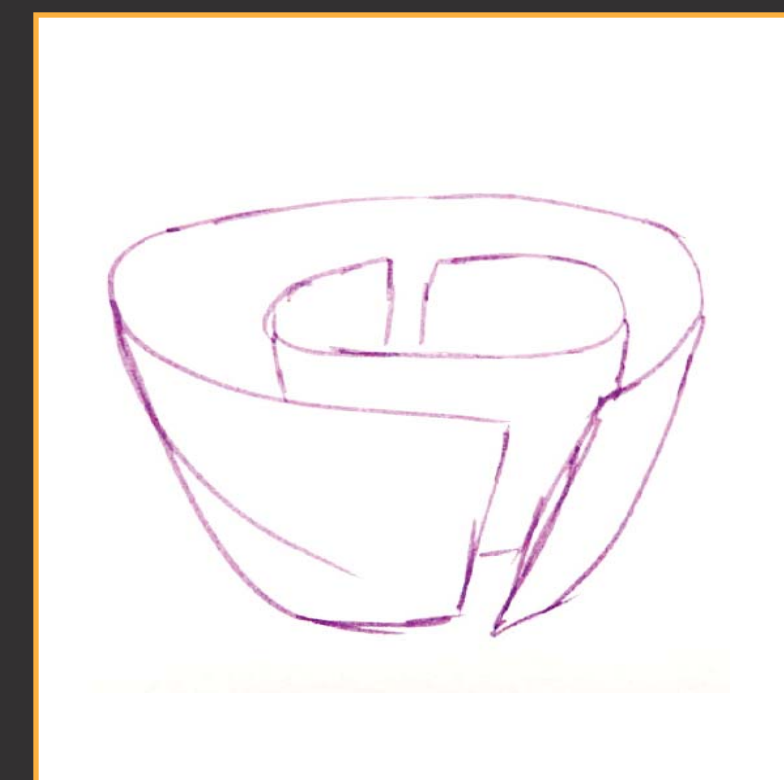

martin luther king maze submitted by carlo



informative workshop @ iit 09/21/09

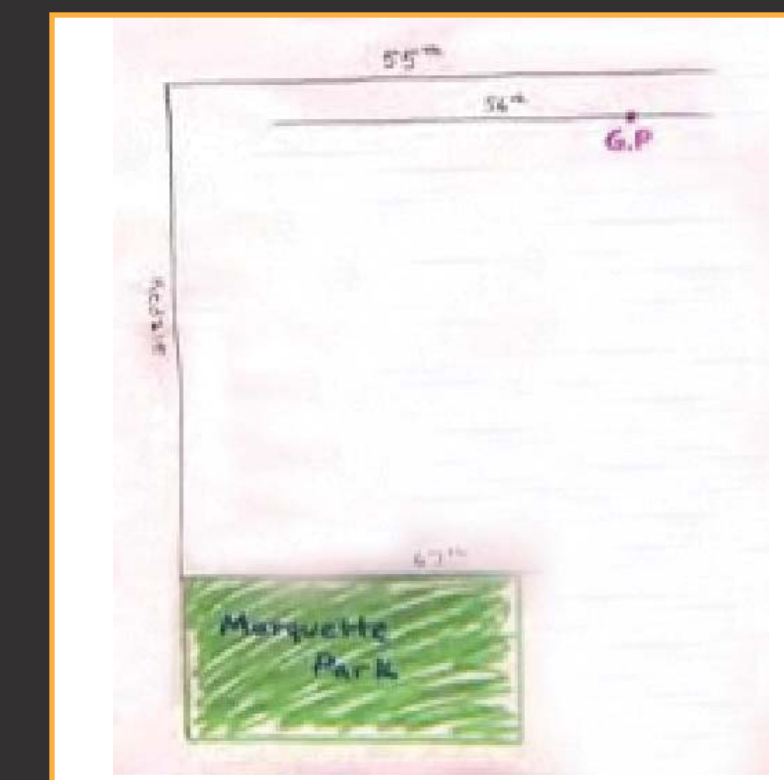

site sketch

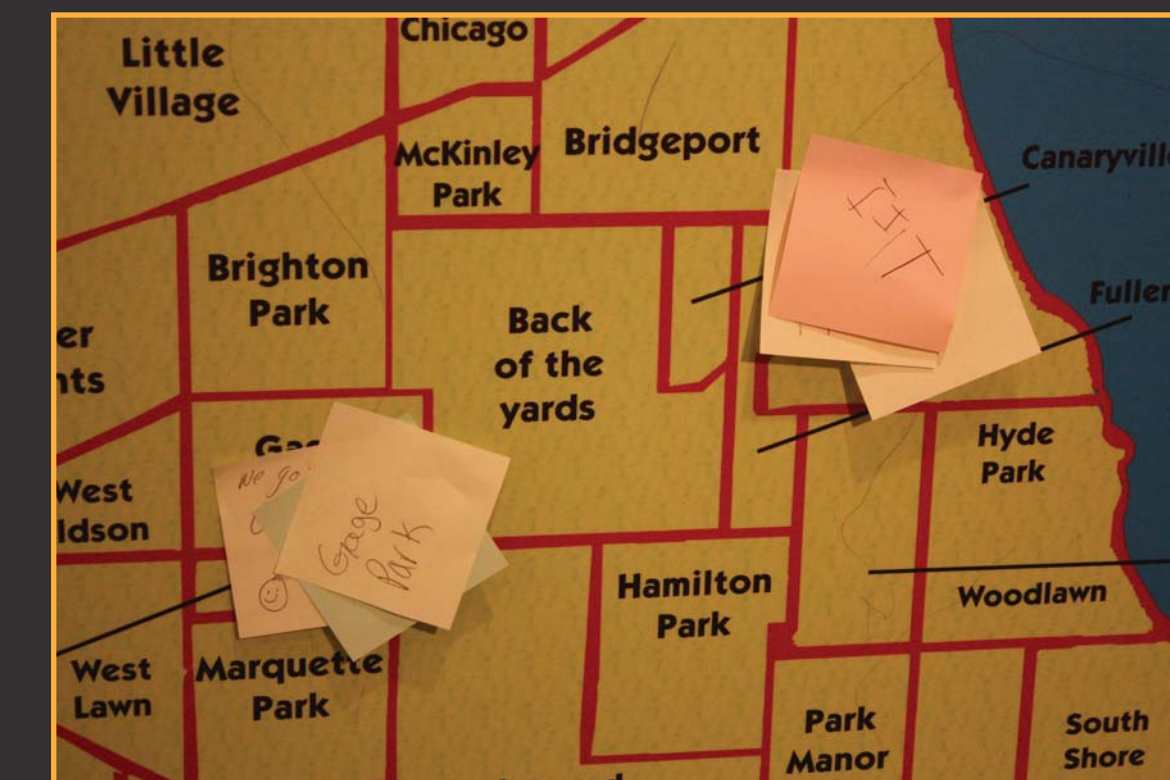

chicago history museum field trip 11/23/09

objective

- keeping student ideas and concerns prevalent
- broadening student visions to develop initial concepts
- developing a prototype based on student ideas

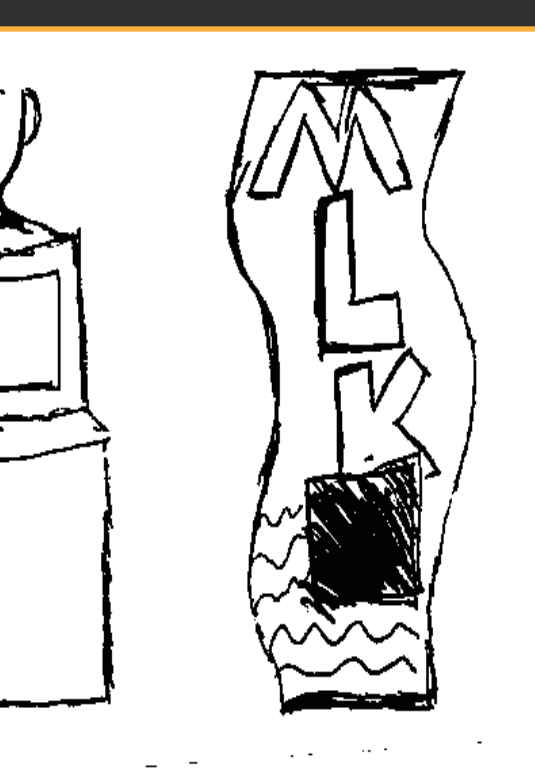

statue kiosk submitted by brandyn



second design workshop @ iit 11/24/09

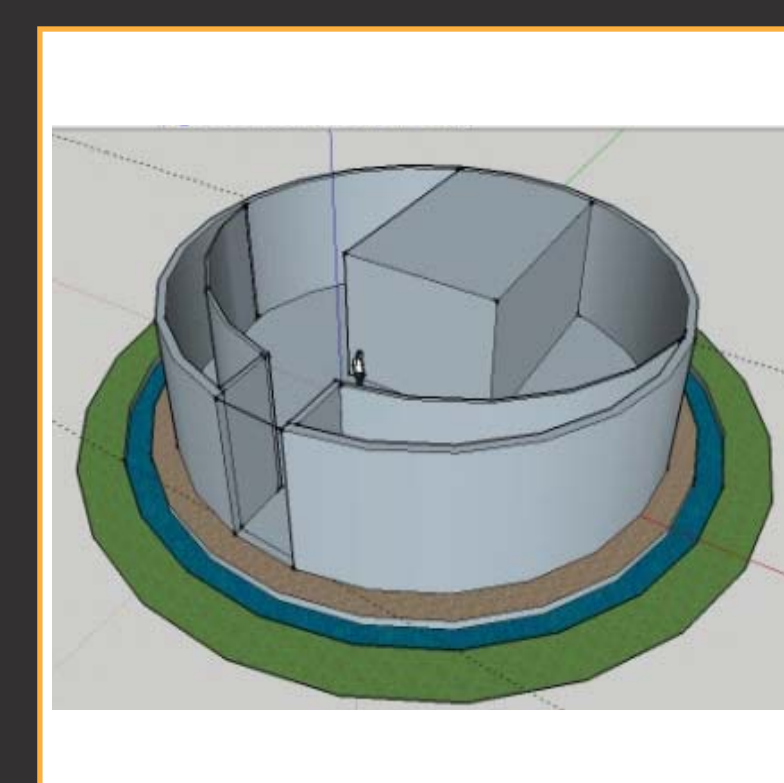

martin luther king pavilion submitted by james

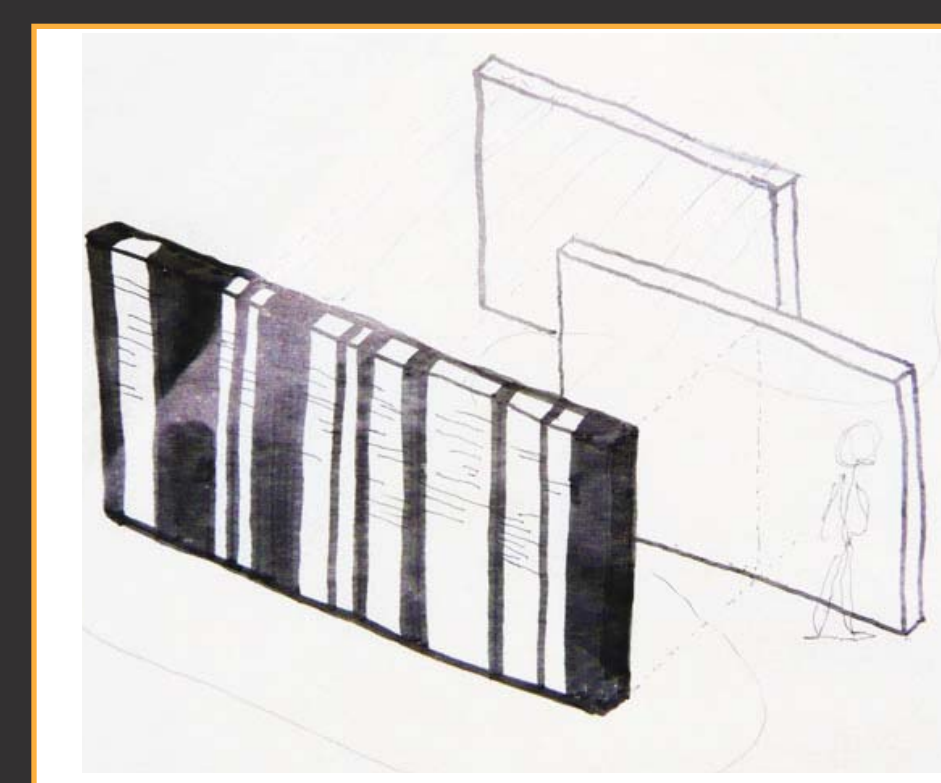

walls of march submitted by eric

methodology

- set up workshops as a tool to interpret student thoughts
- expose students to precedent studies to broaden their ideas
- organize design-based workshops to incorporate the new skills into developing a prototype

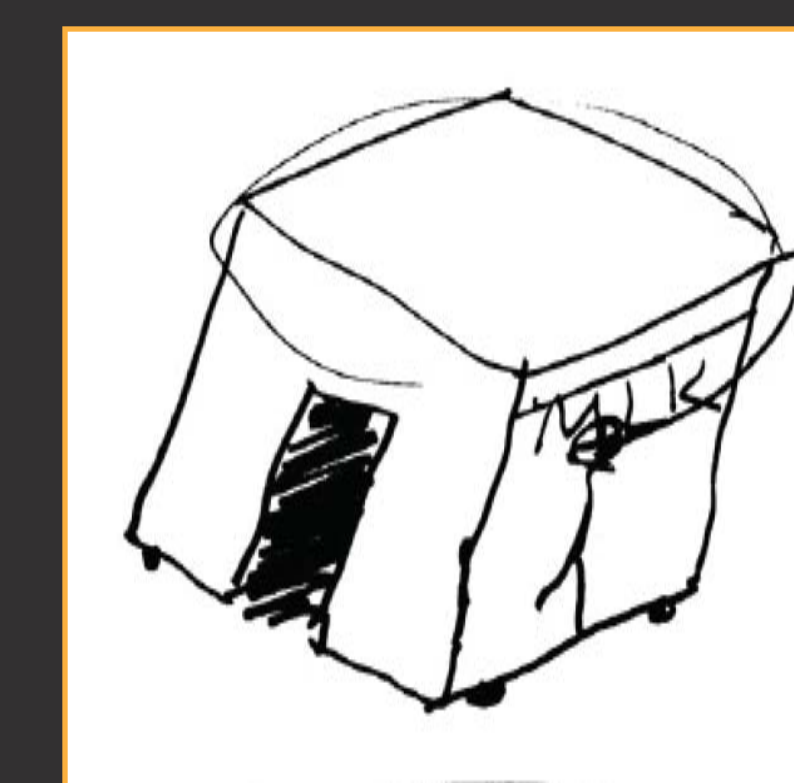

portable memorial station submitted by ayesha

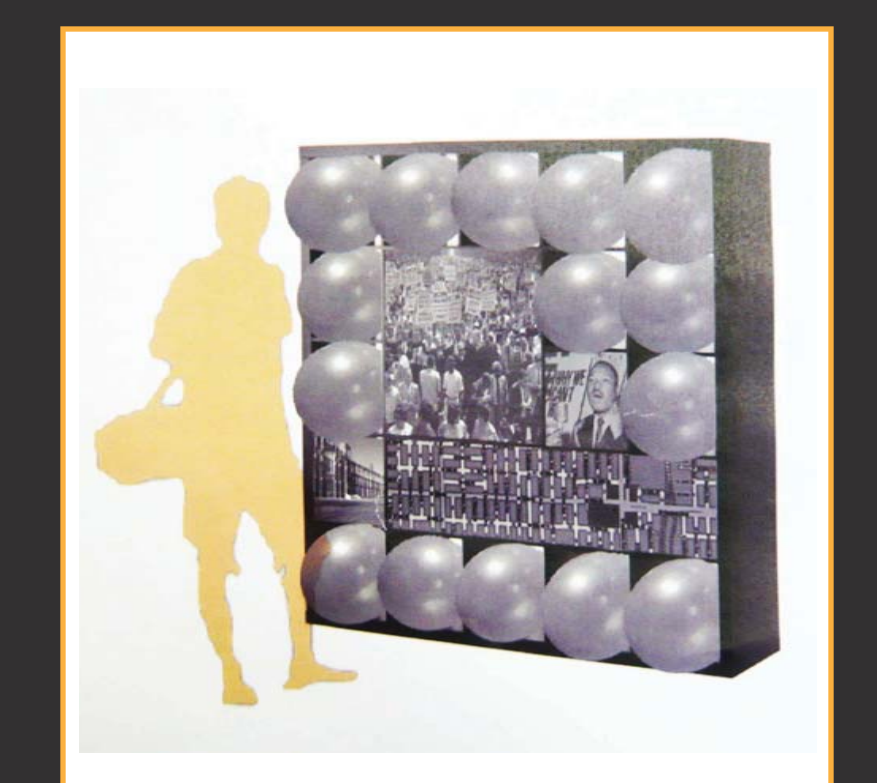

martin luther king balloon memorial submitted by eric

conclusion

workshops helped students to think outside their initial design of an atm machine for the memorial

interactive digital media is the most desired element for the memorial

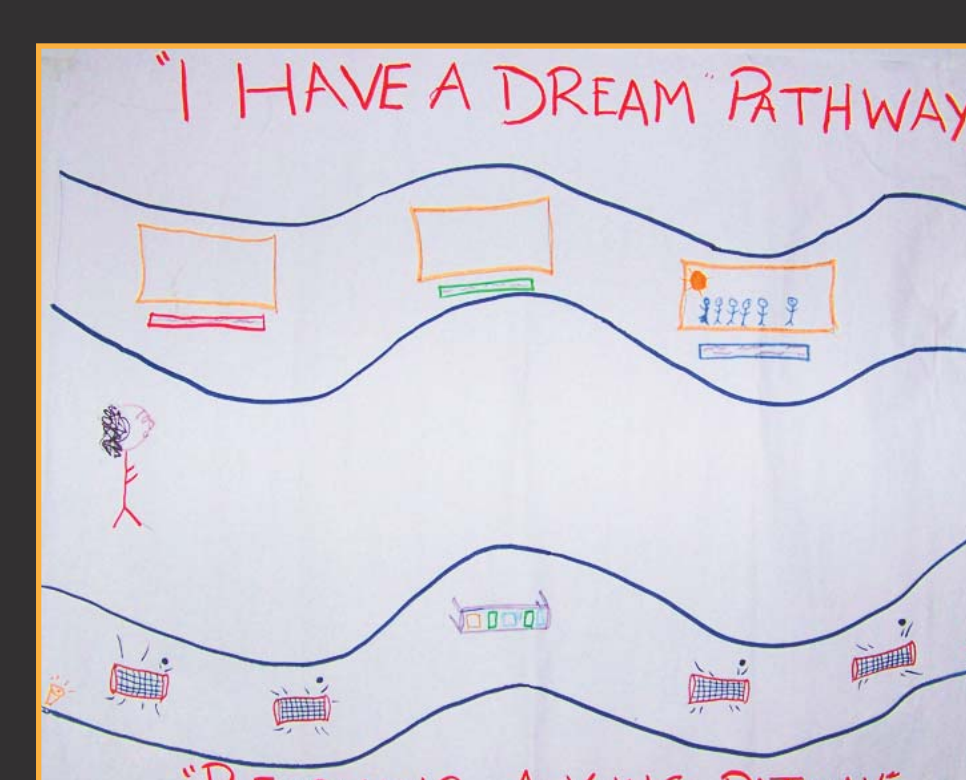

"I have a dream pathway"



first design workshop @ iit 11/23/09

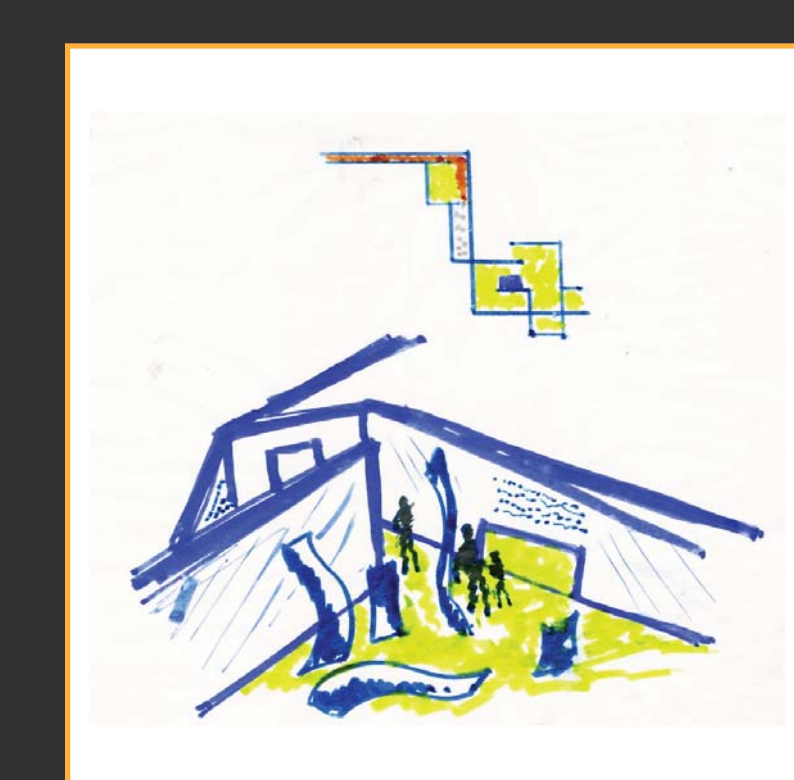

equal housing rights maze submitted by nashrah



second design workshop @ iit 11/24/09



second design workshop @ iit 11/24/09

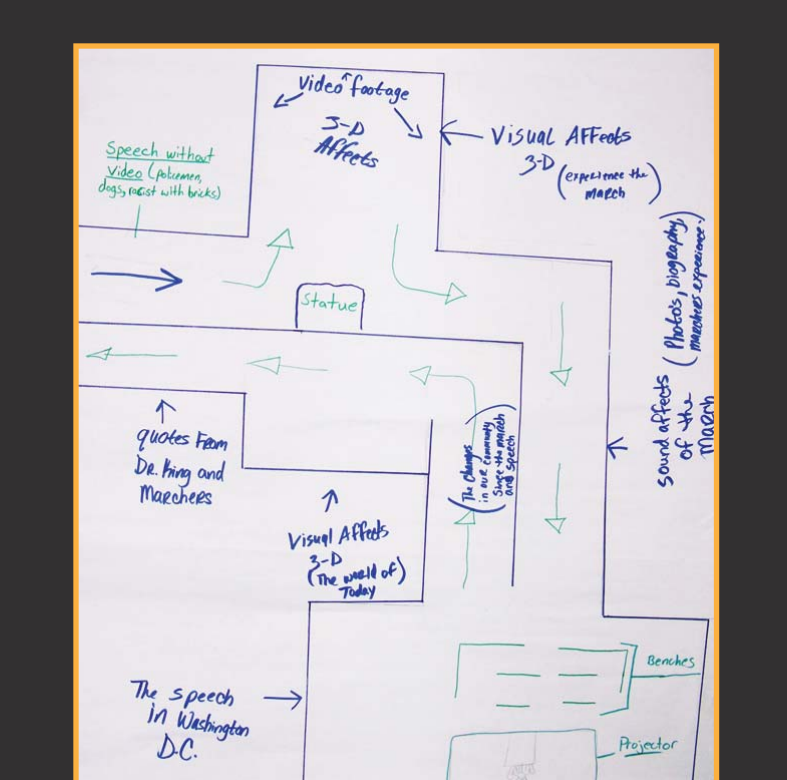

exhibition space design

"OUR LIVES BEGIN TO END THE DAY WE BECOME SILENT ABOUT THINGS THAT MATTER"
- DR. MARTIN LUTHER KING