

I PRO 326 Project Plan

Fall 2008

Steel Bridge Competition Design and Business Planning

Advisor: Chad Fischer

1.0. Abstract

The focus of this IPRO is to design and build a steel bridge to the specifications given by the AISC and by using teamwork. One of the goals of this IPRO is to win this year's ASCE/AISC Regional Steel Bridge Competition, and to place in the top ten in the National Steel Bridge Competition.

2.0. Background

- A. The ASCE Steel Bridge Competition is co-sponsored by ASCE (American Society of Civil Engineers) and AISC (American Institute of Steel Construction). ASCE is an organization that is over 150 years old with a history in engineering and problem solving. The rules for the steel bridge competition are written by AISC and updated yearly.
- B. The students are to design, fabricate and construct a scaled down steel bridge. The rules are based on real life build scenarios. Examples of said problems include: cost of the project, management, design, analysis, fabrication techniques, construction time, efficiency, and safety.
- C. IIT has participated in this competition for many years. Our greatest success is the 2004 competition where the team went to nationals and placed in several events. Scientific issues that will be investigated are different design methods and use of analysis to find the best overall design. Cultural problems arise in communication between the group members who come from different cultures. Ethical problems may arise in scoring of the competition.
- D. All costs are absorbed by the organization involved in solving the problem. There are no costs on society. Any costs arising to businesses are by their own choice through sponsorship.
- E. The solution will be implemented by splitting off tasks into sub groups. There is a

group for designing of the bridge, and to handle the business aspect. The business tasks include fundraising for expenses, keeping track of finances, marketing of the bridge to the IIT campus and the other businesses, and to complete any other administrative tasks.

- F. Students will research past year experiences. Research includes the successes and failures of real life superstructure bridges, and rules of competition.
- G. Attached are the bridge layout rules set by AISC and the introduction and summary of the competition provided by AISC.

3.0. Objectives

A. Marketing

The first objective of the project is twofold. The first part of this is the selling of the bridge to students and faculty and the second is the garnering of support from the local community. By gaining more student and faculty support a larger pool of resources both academic and monetary will be available. This can be done through the encouragement of school pride and something that IIT students can be proud of. Also teachers can greatly help the project by providing the valuable knowledge of marketing and design. In this way they can also actively teach students how to use the things that they are learning inside of the classroom. The bridge could also help to bring pride to the community. Local businesses that contributed to the project will be able to advertise that their materials are of a high quality and are among the best in the nation. The community can also be proud that it has such bright students who are capable of designing the future. This can be done through calling and asking companies for support and donations that will contribute greatly to the building of the bridge. This objective will involve mostly business majors but is able to include everyone in the project due to the fact that everyone can help to market the bridge regardless of their major.

B. Design

The second objective of the project is to design a bridge that meets the requirements specified in the ASCE rule book. Nevertheless it is an unspoken goal that the bridge should perform above and beyond the specifications in the rule book. The design of this bridge will involve architects, civil engineers, mechanical engineers, and material engineers. They will use their specialties to help meet the goals of efficiency, strength, and beauty. This is going to be done by designing a bridge that can be assembled in a quick and efficient manner. Proper materials and the dimensions of the beam that can be used to meet specifications will be strong factors of the design.

4.0. Methodology

Business

1. Contact Companies – (September 10)

- Figure out what we need in budget and materials (Sept 19)
 - Use previous years budgets and receipts as a reference and work with design team to project a final cost
- Find major companies for possible donations and ask for local distributor/contact info
- Write letter and make package (Sept 26)
 - Explain opportunity
 - Past awards
 - Past sponsors
 - Pictures/info of past and present national competitions
- Follow up with phone calls and emails
- Find other contacts and repeat

- Talk to companies around IIT for financial sponsorship

2. Marketing – (Continuous)

- Audience

- Students
 - Involvement
 - School pride
- Administration
 - Department donations
 - Advice/Connections (teachers)
 - ◆ Architecture shop teachers
 - SAF Funding for ASCE
 - Alumni
 - Department Newsletter

- How

- Team t-shirts with logos on back
 - Each member pays \$15 each, possibly sell shirts school wide
 - School already has relationships with T-shirt vendor
 - T-Shirt Design Competition possibility
- Pamphlets/bookmarks
- Tech News Article/IIT Today

3. Website – (September 26)

- Informational Section

- Info for donors
- Info about competition

- Blog and pictures of status updates
- Info about IIT
- Pictures/drawings as they become available
- Done through iGroups
 - Keep track of money
 - Keep track of supplies needed/procured
 - Keep a list of companies for donations
 - Keep a list of contacted companies and their responses
 - Keep track of timeline and adjust as necessary

Design

1. Research [9/2-9/16]

- Real life experiences with bridge design competition
- Previous successes and failures
 - Different connections
 1. IIT past connections
 2. Photos from Nationals
 3. School websites
 - Ways to build
 - Fastest times
- SAP2000 – how to model and analyze?
- Rules / Concept
 - Read and understand rules
 1. Understand the problem
 2. Know scoring requirements
 - Determine bridge shape

2. Development

Design of the bridge with the following considerations:

*Speed, Weight, Deflection, Lateral deflection, and other grading
Connections
Constructability*

- Shape [9/16-9/30]
 - From researching, finalize bridge shape and layout to prepare for analysis
- Computer Modeling [9/30-10/7]
 - Build the bridge model in SAP2000
 - Analyze system to acquire design loads
- Sizing Members [9/30-10/7]
 - Design members for the loads acquired from the computer modeling
- Review-revise [10/7-10/21]
 - Look at current design and analyze possible problems and modifications
- Break Bridge [10/21-11/4]
 - Determine how to split the bridge in order to meet the criteria from the rules
- Connections [10/21-11/4]
 - Design connections for all of the joints in the bridge
- Shop Drawings [10/28-11/18]
 - Draw shop drawings in Auto-CAD detailing connections as they are designed

5.0. Project Budget

Items name	Specifications	Cost
Registration:	School	\$ 125.00
	Individuals	\$ 810.00
Hotel:	7 Rooms @ \$80/night * 3 nights	\$ 1,680.00
	Taxes @ 10.75%	\$ 180.60
Travel:	Gas Reimbursement for driving	\$ 1,164.00
Fabrication:		\$ 4,000.00
	Connectors	
	Tools	
	Wooden forms	
	Hard Hats	
Presentation:		\$ 50.00
	Posters/Printing	
Bridge Aesthetics:		\$ 200.00
	Paint/Decals	
Grand Total:		\$ 8,209.60

6.0. Team Structure and Assignments

Name	Major, Year	Skills and Strengths	Experience and Academic Interest	Team
Keenan Gottschall	Business, 3 rd Year	Have planned and executed many group projects academically, and with organizations. Proficient in MS Office, Quicken accounting software, and AutoCAD	President, officer, or chairman of several project-driven organizations. Currently a Business Administration major with a focus on Finance.	Business Development
Michael McCarthy	Architecture 5 th year	AutoCAD, 3d Studio Max, Adobe Photoshop and Illustrator, presentation development and layout	Worked on numerous academic team projects, strong interest in structural engineering	Team Leader Design Team 2
Peter Olney	Civil Engineering – Structural, 3 rd Year	AutoCAD, MathCAD 14, SAP2000, steel bridge fabrication experience from previous years competition	Experience as an intern at a structural engineering firm doing timber and steel design. Currently a Civil Engineering major with a focus on Structures.	Design Team 2
Mike Hartwig	Civil Engineering, 3 rd Year	Drafting/AutoCAD experience, welding & other mechanical skills, currently enrolled in Structural Design courses.	Eagle Scout, ASCE member. Currently focused in general Civil Engineering.	Design Team 2
Josh Gross	Architecture, 4 th Year	Design	Drawing	Design Team 1
Marcus Choy	Aerospace Mechanical Engineering	Experience arc welding, matlab, currently enrolled in materials and design,	Member of Tau Beta Pi, experience in estimating, used to working in groups to complete projects.	Design Team 2
Randall Weyhe	Architecture	Many rendering skills in 2d and 3d, AutoCAD, some fabrication exp, as well as laser-cutter exp.	Experience at an architecture firm for 1.5 years and dealt with all aspects of design as well as shop drawings	Design Team 1

Tracy Korbus	Architectural Engineering, 4 th Year	Design	Structural analysis and steel design	Design Team 2
Jelena Milkic	Architecture Minor: Construction Management	Design, 3D modeling, AutoCAD, drafting, Adobe Photoshop and Illustrator, multitasking and organizational skills.	Experience in architectural firm as drafter, measuring and inputting drawings, interested in construction management.	Team Leader- Design Team 1
Kevin O'Leary	Business Construction Management	Quicken, AutoCAD, fabricating, previous year competition/construction experience	ASCE Pumpkin launch, ASCE Steel Bridge Captain '08, Member of CMAA, Interned as Construction Engineer.	Business Development
Michael Krueger	Civil Engineering, 3 rd Year	Drafting/AutoCAD, currently in Structural Analysis and Structural Design, Adobe Photoshop and Illustrator	ASCE Member, SGA Vice President, UB VP of Publicity, Leadership Academy Scholar, marketing background	Design Team 1
Lucian Muresan	Civil Engineering, 4 th Year	Management and design	Construction planning	Design Team 1
Justin Van Eaton	Civil Engineering, 3 rd Year	Steel design, web design, structural analysis	Steel design, web design, structural analysis	Design Team 1
Trevor Dickson	Architecture, 5 th Year	Conceptual design, computer graphics	Architecture structures and steel design	Design Team 2
Kaitlyn Conley	Civil and Structural Engineering, 5 th Year	Structures, design, web communications, graphics	ASCE Webmaster	Student Advisor
Heather Grace	Architecture, 5 th Year	Design, business administration	Classes in architecture and structure, professional experience in offices and fundraising	Business Development
Krzysztof Olszowy	Information Technology and Management	MS Office, Customer Relations, and organizational skills	Experience in technical drawing, blueprint reading, interested in network systems and management	Business Development

STUDENT STEEL BRIDGE COMPETITION

2009 RULES

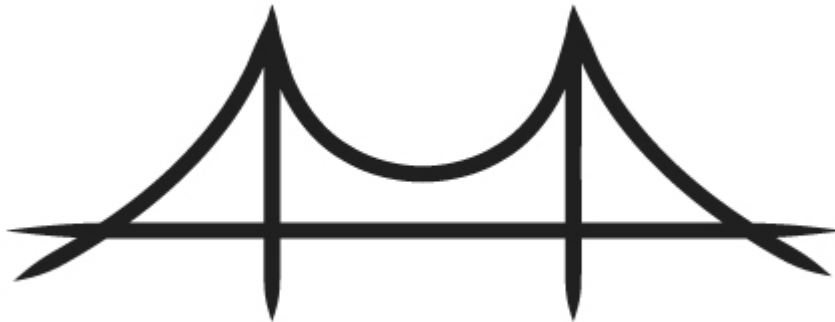

The mission of the ASCE/AISC Student Steel Bridge Competition (SSBC) is to supplement the education of civil engineering students with a comprehensive, student-driven project experience from conception and design through fabrication, erection and testing, culminating in a steel structure that meets client specifications and optimizes performance and economy. The SSBC increases awareness of real-world issues such as spatial constraints, material properties, strength, serviceability, fabrication and erection processes, safety, esthetics and cost. Success in inter-collegiate competition requires effective team work and project management. Future engineers are stimulated to innovate, practice professionalism and use structural steel efficiently.

TABLE OF CONTENTS

	<u>page</u>
1. Introduction	3
2. Executive Summary	4
3. Eligibility	5
4. Rule Changes	7
5. Safety	7
6. Problem Statement	8
7. Scoring	9
8. Schedule of Competition	11
9. Dimensions and Support	12
10. Material and Components	15
11. Construction	17
12. Load Tests	24
13. Equipment Provided by Host	29
14. Interpretation of Rules	30
15. Judging	30
16. Appeals	31
17. Summary of Scoring	33
APPENDIX	
Site and Bridge Diagram	35
Bridge Loading Diagram	36

Any revisions to the rules in this document are incorporated in clarifications that are published at the bridge competition web site, <http://www.aisc.org/steelbridge.html>. Revisions and clarifications do not appear in this document but are considered formal addenda to the *Rules*.

1. INTRODUCTION

The Student Steel Bridge Competition is sponsored by the American Society of Civil Engineers (ASCE) and the American Institute of Steel Construction (AISC), and co-sponsored by the American Iron and Steel Institute, the Canadian Institute of Steel Construction, the James F. Lincoln Arc Welding Foundation, the National Steel Bridge Alliance, the Nucor Corporation, and the Steel Structure Education Foundation.

Students design and erect a steel bridge by themselves but may seek advice from faculty and student organization advisers. Students gain maximum benefit from the experience if they fabricate the entire bridge themselves. However, because appropriate shop facilities and supervision are not available at all universities, students may use the services of a commercial fabricator provided that they develop the work orders and shop drawings, and observe the operations. Students are encouraged to maximize their involvement in fabrication.

Safety is of primary importance. AISC and ASCE request that competitors, advisers, hosts, and judges take all necessary precautions to prevent injury to competitors, judges, volunteers, and spectators.

This document describes the competition and states the rules for this year. It is available at <http://www.aisc.org/steelbridge.html>, together with related information. These rules govern competition at both regional and national levels. Additional information is available at <http://www.nssbc.info>. Information and rules at <http://www.aisc.org/steelbridge.html> will govern if there is a conflict between the two sites.

The rules are changed every year to enhance the competition and assure that competitors design and build new bridges. The rules are intended to be prescriptive but may require some interpretation. The procedure for requesting clarification of the rules is described in chapter "14 Interpretation of Rules." Revisions to the rules, if any, will be incorporated in the clarifications that appear on the web page cited in that chapter.

2. EXECUTIVE SUMMARY

Civil Engineering students are challenged to an inter-collegiate competition that includes design, fabrication, and construction of a scaled steel bridge. Participating students gain practical experience in structural design, fabrication processes, construction planning, organization, and teamwork.

The rules of the competition simulate a request for proposal that requires a scaled model to demonstrate the efficacy of competing designs. Chapter “6 Problem Statement” relates the rules to realistic challenges encountered in bridge design and construction.

Standards for strength, durability, constructability, usability, functionality, and safety reflect the volumes of regulations that govern the design and construction of full-scale bridges. Criteria for excellence are represented by the award categories of stiffness, lightness, construction speed, display, efficiency, and economy. Competition judges and the Rules Committee take the role of the owner (Department of Transportation) and have the authority to accept and reject entries.

The safety of competitors, judges, volunteers, and spectators is paramount. Risky procedures are prohibited, and bridges that cannot be constructed and tested safely are withdrawn from competition. In addition, the rules identify and penalize construction errors that represent accidents in full-scale construction.

The rules of the competition accommodate a variety of designs and allow innovation. Designers must consider carefully the comparative advantages of various alternatives. For example, a truss bridge may be stiffer than a girder bridge but slower to construct. Successful teams analyze and compare alternative designs prior to fabrication.

The Student Steel Bridge Competition provides design and construction planning experience, an opportunity to learn fabrication procedures, and the excitement of competing against and networking with students from other colleges and universities.

3. ELIGIBILITY

3.1. Regional Competition

There are two levels of competition: regional and national. Regional competitions are held in conjunction with ASCE student conferences. Only one bridge per college or university may compete in an ASCE student conference, and a college or university may compete in only one ASCE student conference.

The ASCE student organizations entering regional competitions are required to be current with their national dues and annual reports. A team must consist only of undergraduate and graduate students in good standing with their ASCE student organization.

The conference host organization may invite a student team to participate as a guest if that team does not have an ASCE student organization that meets the requirements of the preceding paragraph or has been assigned to a different conference. Such guest teams will not be ranked in the competitions nor will they be invited to compete in the National Student Steel Bridge Competition.

An ASCE student organization will not be permitted to participate in the National Student Steel Bridge Competition unless it competes in the ASCE regional conference to which it has been assigned and satisfies ASCE requirements regarding participation in that conference. These requirements, as they existed in July, 2008, are reprinted in section 3.3. The requirements are subject to change; the most recent version is on the web page <http://content.asce.org/student/eligibility.html>.

The official scoring spreadsheet for a regional competition must be submitted to aftbq@uaa.alaska.edu before the eligible teams from that region will be invited to the national competition.

3.2. National Competition

Invitations to compete at the national level are extended only to the eligible winner from an ASCE student conference in which two, three, or four ASCE student organizations competed in the Student Steel Bridge Competition, to the top two eligible teams from a conference in which five to ten ASCE student organizations competed, and to the top three eligible teams from a conference with eleven or more competing ASCE student organizations. Guest teams and teams that did not present credible bridges will not be counted when determining how many teams will be invited from a conference. Guest teams will not be invited to the national competition. Only one bridge per college or university may be entered in the national competition.

3.3. ASCE National Competition Eligibility Requirements

The following paragraphs on this page were transcribed from the ASCE web page <http://content.asce.org/student/eligibility.html> on July 18, 2008; that page should be consulted for the most recent version. ASCE has sole authority for determining and enforcing these requirements; questions should be sent by e-mail to student@asce.org.

In order to facilitate broader participation by ASCE Student Organizations in Student Conference activities, the ASCE Committee on Student Activities (CSA) stresses the importance of the conference as an event that is much more than a qualifying round for national competitions and highlights the required events at a conference. As such, the following qualifications are required of all ASCE Student Organizations in order to participate in an ASCE-sponsored National Competition.

An ASCE Student Organization must:

1. Be in good standing with ASCE (annual report and annual dues submitted and received by ASCE prior to the start of the Student Conference).
2. Attend and participate in their assigned Student Conference as shown through their school's:
 - a) Good faith participation in the Student Conference Business Meeting (i.e. on time attendance by at least one student representative);
 - b) Good faith participation in the Student Conference Paper Competition (i.e. submission and presentation by at least one member of the ASCE Student Organization); and
 - c) Meeting any additional requirements of Student Conference participation set by the Student Conference at the previous year's business meeting or in their written and approved by-laws, standing rules, or constitution.

Note: The concrete canoe design paper/oral presentation does not count as an entry into the Student Conference Paper Competition.

4. RULE CHANGES

The following list covers some of the major changes from the 2008 rules. Not all changes are listed. Contestants, hosts, and judges are cautioned to **read this entire document carefully and disregard rules and clarifications from previous years.**

1. A deck bridge is required (i.e., the entire superstructure is below the deck).
2. Required clearances have changed.
3. Decking support surfaces must not have vertical protrusions.
4. Threaded holes are not allowed (e.g., nuts shall not be welded to members).
5. There is only one staging yard.
6. There are no revetments.
7. Assemblies are not permitted.
8. Builders may partially support the constructed portion.
9. Costs have changed.
10. The official scoring spreadsheet for a regional competition must be submitted before appeals are considered and before teams are invited to the national competition.

5. SAFETY

Safety has the highest priority. Judges are empowered to halt any activity that they deem hazardous. Judges will stop construction procedures that could cause personal injury. Judges will not allow additional load to be placed on a bridge that has collapsed, that is approaching a collapse that could be dangerous, or that has swayed or deflected in excess of specified limits. A bridge that cannot be safely constructed or load tested using the equipment provided by the host is not eligible for awards in any category and must be withdrawn from participation.

6. PROBLEM STATEMENT

A century-old highway bridge that spans a scenic river must be replaced. The bridge carries traffic serving residences and resorts that are the foundation of the economy for this rural region. A quick replacement is necessary because no other crossing is available for miles.

The state Department of Transportation (DOT) has requested design/build proposals for replacing the existing bridge. A deck bridge is specified to provide unobstructed views of the river and surrounding scenery. Clearance under the bridge must be provided for passage of kayaks and similar small craft. In addition, the bridge must straddle the right-of-way for a proposed multi-use trail bridge. The DOT has specified steel as the material because of its fast erection and exceptional sustainability rating, based on durability and high level of recycled content. The bridge must be able to carry specified patterns of loads without exceeding sway and deflection limits. Based on past experience with performance and maintenance, the DOT prefers bridges that are relatively light and stiff. The new bridge must accommodate modular decking that was salvaged from another structure.

Due to environmental concerns, construction of permanent piers is permitted only on the existing footings. However, temporary piers may be used. Construction barges are permitted in the river. The floodway adjoining the river is too shallow for barges and too wet for terrestrial construction machinery. Soil conditions limit the weight of loads that may be moved. Site conditions allow construction only from one bank and from barges.

Your company's design/build proposal is among those that the DOT has deemed responsive, and winning the contract would be a step toward becoming a leader in the bridge replacement market. The DOT has asked each competing firm to submit a 1:10 scale model to demonstrate its concept. Models will be erected under simulated field conditions and then load tested. A panel of DOT personnel will judge the models by multiple criteria including durability, constructability, usability, stiffness, construction speed, efficiency, economy, and display. The contract will be awarded to the company whose model best meets the DOT's needs and requirements. Any attempt to gain advantage by circumventing the intent of the competition as expressed by the rules, including this Problem Statement, will be grounds for rejection of the model and termination of the company's eligibility.

7. SCORING

A bridge will not be ranked if it is entered by an organization that is not in good standing with ASCE or that is competing in a conference to which it has not been assigned by ASCE. A college or university may enter only one bridge in regional competition and may participate in only one regional competition.

Categories of competition are display, construction speed, lightness, stiffness, construction economy, and structural efficiency. In addition, overall performance is rated. A bridge that was not approved for load testing or that failed in load testing is not eligible for awards in any category.

7.1. Display

Display is the tie-breaker for all categories of competition. Judges shall not declare ties in display. The bridge is displayed exactly as it will be erected during timed construction. Display is judged by

7.1.1. Appearance of bridge, including balance, proportion, elegance, and finish. Quality of fabrication shall not be considered because some bridges may be fabricated professionally while others are student work.

7.1.2. Permanent identification of the bridge consisting of the name of the college or university exactly as shown on the ASCE register available at <http://content.asce.org/student/websites.html>. The name must appear on the bridge in letters at least one inch high and must be formed from steel or applied to steel with paint or decals. A thirty-pound weight penalty will be imposed if the bridge lacks appropriate identification.

7.1.3. Poster describing design. The poster must be flat with maximum dimensions of two by three feet and must present all information on one side without attached pages that must be lifted or turned. The poster must identify the college or university with the same name that appears on the bridge and must present a brief explanation of why the overall configuration of the bridge was selected, a brief computation demonstrating design for one limit state, a scaled, dimensioned side view of the bridge, and acknowledgment of companies, university technicians, faculty, and others who helped fabricate the bridge or provided advice. Sustainability of the design is indicated by listing or designating on the drawing those parts of the bridge that were salvaged from previous bridges or projects, or obtained from salvage yards. Additional information may be included. Electronic displays, decorated supports, lights, and sound are not permitted and will result in the worst possible rating for the poster. A fifty-pound weight penalty will be imposed if there is no poster or if it is grossly inadequate. The poster is not part of the bridge but must be in place whenever the bridge is on display.

7.2. Construction Speed

The bridge with the lowest total time will win in this category. Total time is defined as the time required for construction, modified by penalties prescribed in sections 11.6, 11.7, 11.9, 12.2, 12.4, and 12.5, plus 150% of repair time (see section 11.9). There is an upper limit on construction time (see section 11.6).

7.3. Construction Economy

The bridge with the lowest construction cost (C_c) will win in the construction economy category. Construction cost (thousand \$) is computed as

$$C_c = \text{Total time (minutes)} \times \text{Number of builders (including barges)} \\ \times 50 \text{ thousand dollars per builder-minute} \\ + 50 \text{ thousand dollars for one temporary pier even if none is used} \\ + 50 \text{ thousand dollars for each additional temporary pier.}$$

Total time is defined in section “7.2 Construction Speed” and includes penalties. The number of builders includes all members and associates of the competing organization who are within the construction site or physically assist the team at any time during timed construction.

7.4. Lightness

The bridge with the least total weight will win in the lightness category. Total weight is the weight of the bridge plus weight penalties prescribed in sections “7.1 Scoring: Display,” “9.2, 9.3, and 9.4 Usability, Member-to-member Connections, and Nominal Centerline,” “10.2 Durability and Constructability” and “12.4 and 12.5 Lateral Load Test and Vertical Load Test.” Decking, tools, temporary piers, and poster are not included in total weight.

7.5. Stiffness

The bridge with the lowest aggregate deflection will win in the stiffness category. Aggregate deflection is determined from measurements as prescribed in section “12.5 Vertical Load Test.”

7.6. Structural Efficiency

The bridge with the lowest structural cost (C_s) will win in the structural efficiency category. Structural cost (thousand \$) is computed as

$$C_s = \text{Total weight (pounds)} \times 5 \text{ thousand dollars per pound} \\ + \text{Aggregate deflection (inches)} \times 700 \text{ thousand dollars per inch.}$$

Total weight is defined in section “7.4 Lightness” and includes penalties. Aggregate deflection is defined in “7.5 Stiffness” and includes penalties.

7.7. Overall Performance

The overall performance rating of a bridge is the sum of construction cost and structural cost ($C_c + C_s$). The bridge achieving the lowest value of this total wins the overall competition.

8. SCHEDULE OF COMPETITION

In the months before the competition, students design their bridges, fabricate members, test load, practice construction, and select a member of the team to serve as its captain. The following events occur during the competition

1. Bridges are erected for public viewing and are judged for display. After the start of display judging, bridges must not be altered, modified, or enhanced in any way except for disassembly, erection, and repairs as described in section “11.9 Construction: Repairs.”
2. Bridges are disassembled.
3. In a meeting at which all team captains are present, the head judge clarifies rules and conditions of the competition and answers questions.
4. The head judge selects the locations of loads. See section “12.5 Vertical Load Test” and the “Locations of Targets and Decking” detail on the “Bridge Loading” diagram. Selection is done in the presence of the team captains by rolling a die twice. Let S1 and S2 be the spots from the two rolls and let L1 and L2 be dimensional locations of decking units in inches.
$$L1 = 40 + 6 (S1) \quad \text{and} \quad L2 = 110 + 6 (S2)$$
The same locations will be used for all bridges in the competition.
5. Bridge members, fasteners, tools, and temporary piers are staged for construction and inspected by the judges. See chapter “10 Material and Components,” rules 9.3.2 and 9.3.3, and section “11.4 Start” for details.
6. Timed construction. See chapter “11 Construction” for details.
7. Judges inspect assembled bridges. For details, see chapter “9 Dimensions and Support” (including rules 9.3.2 and 9.3.3 as they apply to installation of fasteners) and rules 10.1.2 and 10.1.3.
8. Bridges are weighed (if it is impractical to weigh the entire bridge, its parts may be weighed prior to construction).
9. Load testing. See chapter “12 Load Tests” for details.
10. Scores and rankings are determined using the official scoring spreadsheet found at www.nssbc.info and the host ASCE student organization submits the completed official scoring spreadsheet by e-mailing it to the address given on that spreadsheet, which is aftbq@uaa.alaska.edu.
11. Summary score sheets can be printed from the official scoring spreadsheet and are distributed to all teams or posted on the host’s web site.

The order recommended above may be altered. However, it is essential that

- bridges are not modified after selection of load locations,
- bridges are not modified between display judging and timed construction,
- no components or tools are added to or removed from the construction site after staging and inspection, and
- modifications between timed construction and load testing are limited to repairs as described in “11.9 Repairs.”

9. DIMENSIONS AND SUPPORT

Dimensions and support will be checked with the bridge in its as-built condition after construction is completed and before the bridge is moved from the construction site or load tested. The bridge must not be modified or distorted from its as-built condition in order to satisfy dimension and support rules. Dimensions will be checked without decking or any applied load on the bridge.

9.1. Functionality and Safety

If any of the following rules in this section (9.1) is violated, the bridge will not be approved for load testing and will not be eligible for awards in any category.

9.1.1. The bridge must span the river and floodway completely without touching them. See the "Site Plan" on the "Site and Bridge" diagram.

9.1.2. The bridge must provide support for the decking for the full overall length of the bridge along both of the edges that run in the span direction of the bridge. See the "Elevation" on the "Site and Bridge" diagram.

9.1.3. The bridge must provide access for placing the decking and load.

9.1.4. The decking must not be attached or anchored to the bridge, and it must not be used to distort the bridge from its as-built condition.

9.1.5. The bridge must not be anchored or tied to the ground.

9.1.6. It must be possible to construct and load the bridge safely using equipment provided by the host student organization. **Bridges must accommodate local conditions.**

9.2. Usability

A weight penalty will be assessed for each rule in this section (9.2) that is violated, rather than for every violation of that rule.

The penalty for violation of each of the following rules will be an addition to the weight of the bridge determined as follows

- 50 pounds for a dimensional violation of $\frac{1}{2}$ inch or less;
- 150 pounds for a dimensional violation greater than $\frac{1}{2}$ inch but not exceeding 1.0 inch;
- 300 pounds for a dimensional violation greater than 1.0 inch but not exceeding 2.0 inches;
- If a dimensional violation exceeds 2.0 inches, the bridge will not be approved for load testing and will not be eligible for awards in any category.

- 9.2.1. The bridge must bear on the ground only within the one-foot by one-foot squares that are marked on the construction site to represent existing footings. See the “Site Plan” on the “Site and Bridge” diagram.
- 9.2.2. Decking support surfaces must not be more than 20’0” long and must extend for the overall length of the bridge.
- 9.2.3. Parts of the bridge (including fasteners and parts that bear on the ground) must not extend beyond the vertical plane defined by the ends of the decking support surfaces at each end of the bridge.
- 9.2.4. The bridge must be able to accommodate solid decking at all points along the length of the bridge.
- 9.2.5. The lateral distance from the nominal centerline to the outer edge of the outermost decking support surface on each side of the bridge must not be less than 1’3”. See the “Decking Support” detail on the “Site and Bridge” diagram.
- 9.2.6. The lateral distance from the nominal centerline to the inner edge of the outermost decking support surface on each side of the bridge must not be more than 1’6½”. See the “Decking Support” detail on the “Site and Bridge” diagram.
- 9.2.7. The decking support surfaces must not have gaps exceeding ¼ inch measured in the span direction of the bridge.
- 9.2.8. The decking support surfaces must be smooth, without vertical protrusions or abrupt changes in elevation. This rule may be checked by sliding a decking unit or template along the full overall end-to-end length of the decking support surfaces.
- 9.2.9. The decking support surfaces must be no more than 2’6” above the surface of the ground or river at any point. See the “Elevation” on the “Site and Bridge” diagram.
- 9.2.10. No part of the bridge shall extend above the decking support surfaces at any transverse section along the length of the bridge.
- 9.2.11. Clearance must be provided under the bridge at all points directly over the river, floodway, and ground, except directly over the footings. The clearance must be at least 5½” high, measured from the surface of the river, floodway, and ground. See the “Elevation” on the “Site and Bridge” diagram.
- 9.2.12. A straight passageway under the bridge must completely traverse it from end to end. It must be at least 2’0” high measured from the surface of the river and ground, must be at least 3’0” wide measured perpendicular to the nominal centerline, and must pass between the footings at each end of the bridge. See the “End View” on the “Site and Bridge” diagram.

9.3 Member-to-member Connections

Violations of the rules in this section (9.3) will result in penalties being added to the weight of the bridge. The penalty for each violation is 25 pounds.

9.3.1. Each member must be connected directly to every member that it touches by at least one fastener installed during timed construction so that the connection cannot be taken apart without first turning and removing a nut from the bolt. Rules governing members and fasteners are stated in chapter 10.

9.3.2. The bolt must penetrate completely through a hole in each of the members that it connects. Dimension(s) of the hole must be small enough so that neither the head of the bolt specified in rule 10.2.8 nor the nut specified in rule 10.2.9 can pass through the hole.

9.3.3. The hole for a fastener shall not be threaded. It must be possible to install and remove the bolt without turning it.

9.3.4. The bolt must fully engage the threads of the nut(s). That is, the end of the bolt must extend beyond, or be flush with, the outer surface of the outermost nut.

9.4. Nominal Centerline

A weight penalty of 100 pounds will be assessed if any of the requirements in this section (9.4) is violated or if some feature of the bridge prevents the judge from stretching a string along a designated straight nominal centerline.

9.4.1. The bridge must have a designated straight nominal centerline extending from one end to the other. The centerline must be designated by two holes, one at each end of the bridge, drilled vertically through horizontal steel surfaces at the level of the decking support surfaces. Each hole must be approximately $\frac{1}{4}$ inch in diameter and must be located no more than 3'0" from the vertical plane defined by the ends of the decking support surfaces.

10. MATERIAL AND COMPONENTS

10.1. Safety

If any one of the following rules in this section (10.1) is violated, the bridge will not be approved for construction or load testing, and will not be eligible for awards in any category.

10.1.1. A member must not weigh more than twenty pounds. See section 10.2 for definition of “member.”

10.1.2. A bridge must not incorporate an electric, electronic, fluidic, or other non-mechanical sensor or control system; a non-mechanical energy transmission device such as a wire, duct, or tube; an energy conversion or storage device such as an electromagnet, electric cell, motor, hydraulic or pneumatic piston, turbine, chemical reactor, pressure vessel, pre-loaded spring, or triggering device.

10.1.3. After completion of timed construction, energy must not be transmitted to or from a bridge (for example, by applying or releasing mechanical, magnetic, fluidic, or other force; by sound, light, radio, or other wave or ray; by conduction or convection of heat; or by electric current). The exceptions are forces necessary to the competition (for example, those associated with load testing and with moving the bridge from place to place), and changes in ambient conditions that are not controlled by contestants (such as wind, temperature, and lighting).

10.2. Durability and Constructability

Violation of the following rules in this section (10.2) will result in penalties being added to the weight of the bridge. The penalty for each violation is 25 pounds.

Bridge

10.2.1. A bridge must be constructed only of structural steel. For the purposes of this competition, structural steel is defined as an iron alloy that is strongly attracted to the magnet provided by the host organization. Solder, brazing, and structural adhesives are not permitted. Exceptions: Purely decorative items such as coatings and decals are permitted, and bridge parts may be labeled.

10.2.2. A bridge must be constructed only of members and fasteners.

Members

10.2.3. A member is a rigid steel component that retains its shape and dimensions during timed construction and in the completed bridge.

10.2.4. A member must not exceed overall dimensions of 3'6" x 6" x 6." That is, it must fit in a prismatic box of those dimensions.

10.2.5. A member must retain its shape, dimensions, and rigidity during timed construction and load testing. Hinged, jointed, articulated, and telescoping members are prohibited, as are those with parts that move. This prohibition includes members with parts that are intended to slide, rotate, deflect, or bend relative to the member such as cams, latches, sliding pins, springs, and snap-lock devices. Also prohibited are members incorporating hinges or other devices that do not restrain rigid-body rotation or translation of one part of the member relative to another. Exception: Deformations caused by mechanical strain (e.g., bending, stretching) during load testing are not violations.

10.2.6. A member may consist of multiple parts rigidly joined together before timed construction begins. Those parts must remain rigidly joined throughout timed construction and in the completed bridge. Parts must be joined by welding or with steel connectors such as bolts, screws, and rivets. If nuts are used, their threads must be fully engaged (that is, the end of the bolt or threaded stud must be flush with or extend beyond the outer face of the nut).

Fasteners

10.2.7. A fastener is a steel bolt that is not part of a member, with at least one steel nut that is not part of a member. The specified bolts and nuts usually are available in hardware stores.

10.2.8. The bolt in a fastener must be no more than three-inch nominal length (bottom of head to end) with a hexagonal head, and it must have the configuration and dimensions of an A325 or A490 high-strength bolt or of a non-high-strength hex or heavy hex bolt as listed in Tables 7-15 and 7-20, respectively, of the *Steel Construction Manual* (AISC, thirteenth edition). Bolts shall not be mechanically altered or modified in any way but may be painted.

10.2.9. The nuts in a fastener must match the bolt. That is, the nominal size (inside diameter) must be the same as that of the bolt and the threads of the nuts must fully engage the threads on the bolt and permit the nuts to be turned onto the bolt. Nuts must be solid, hexagonal, and have the configuration and dimensions of an A563 nut or of a non-high-strength hex or heavy hex nut as listed in the tables cited in rule 10.2.8. Nuts must not be mechanically altered or modified in any way but may be painted.

10.2.10. Nuts and bolts that connect the parts of a member but do not connect a member to other members are not considered to be fasteners and are not governed by rules 10.2.7, 10.2.8, and 10.2.9.

11. CONSTRUCTION

11.1. Definitions

11.1.1. “River,” “floodway,” “staging yard,” “footing,” “moorage” and construction “site boundary” are defined by the “Site and Bridge” diagram. “Ground” is the entire floor, both inside and outside the site boundary, except for the river.

11.1.2. “Builders” are undergraduate or graduate student members of a competing student organization. See chapter 3 for eligibility requirements.

11.1.3. A “barge” is a builder who is designated to begin, remain, and end timed construction in the river. Builders cannot be designated as barges after the start of timed construction and builders so designated remain barges for the duration of timed construction. The use of barges is optional. Barges are counted as builders.

11.1.4. A “team” is all the builders from the competing organization who are in the construction site during timed construction. The team shall include no more than six builders. No more than three of those builders shall be designated as barges.

11.1.5. “Personal protective equipment” consists of a hardhat meeting ANSI standard Z89.1 and protective eyewear or safety goggles meeting ANSI standard Z87.1. A team provides its own personal protective equipment.

11.1.6. A “tool” is a device that is used to construct the bridge and is not part of the completed bridge. A team provides its own tools.

11.1.7. “Temporary piers” are optional devices that bear on the river or ground, and are used to support the constructed portion of the bridge during timed construction. They have no other purpose, are not tools, and are not part of the completed bridge. A team provides its own temporary piers. The construction cost, C_c , includes an increment for one temporary pier even if none is used, plus an increment for each additional temporary pier.

11.1.8. “Member” and “fastener” are defined in section 10.2. “Member-to-member connection” is defined in section 9.3.

11.1.9. To be “moored” means that a barge is in the river with one foot on a portion of the line marking the edge of the river that is designated as a moorage. Only one barge can be moored at each moorage.

11.1.10. The “constructed portion” is created during timed construction by placing members in essentially their final positions. The constructed portion is not required to be contiguous.

11.1.11. When a member is placed in essentially its final position it becomes part of the constructed portion and is no longer considered to be a member.

11.2. Safety

If any rule in this section (11.2) is violated during timed construction, the judge will stop the clock and explain the violation. Before the clock is restarted, builders, tools, members, fasteners, and temporary piers will be returned to the positions they occupied before the violation. Then the team will be asked to resume construction using safe procedures. A team will have the opportunity to construct its bridge safely. However, if the team is not able to construct its bridge completely using safe procedures, construction will cease and the bridge will not be approved for load testing and will not be eligible for awards in any category.

11.2.1. Builders, judges, volunteers, and spectators must not be exposed to risk of personal injury.

11.2.2. Only builders and judges are permitted within the boundaries of the construction site during timed construction and repair.

11.2.3. At all times during timed construction and repair every builder must wear personal protective equipment in the proper manner (e.g., hardhat with peak in front).

11.2.4. Welding machines and tools requiring external power connections must not be used during timed construction or repair.

11.2.5. A tool must not weigh more than twenty pounds and must not exceed 3’6” in any linear dimension when fully assembled and extended.

11.2.6. A temporary pier must not weigh more than twenty pounds and must not exceed 1’6” in any horizontal dimension.

11.2.7. A tool must not touch a temporary pier.

11.2.8. A temporary pier must not be moved while it is supporting the constructed portion.

11.2.9. A temporary pier must not collapse or fall over while in use.

11.2.10. A temporary pier must bear on the river or ground within the construction site and not be supported or stabilized by a builder while it is supporting the constructed portion.

11.2.11. Lubricant must not be applied during timed construction or within the construction site at any time. Lubricant must not drop on the floor within the construction site.

11.2.12. Throwing anything is prohibited.

11.2.13. A builder must not use the bridge, a portion of the bridge, a temporary pier, or a tool to support the builder's body weight. For example, lying, standing, sitting, or kneeling on those objects is prohibited. However, a builder may lean on a constructed portion if the builder is kneeling on the ground on both knees, kneeling on the ground on one knee with the other foot on the ground, or standing with the heels and toes of both feet on the ground.

11.2.14. A builder must not depend on another builder or builders for support or balance.

11.2.15. A builder must not cross the floodway or the river.

11.2.16. A constructed portion must be created in, and remain in, essentially the same location, position, and configuration that it will have in the completed bridge. Exceptions

- A former member that is connected to the constructed portion by only one fastener may rotate relative to the constructed portion.
- Due to lack of support from members that have not yet been connected to the constructed portion, part of it may sag or sway.
- The constructed portion may slide from its final position on the ground as an unintended consequence of construction. However, intentional movement of the constructed portion from its final position is a violation.

For all three exceptions, one or more builders may move all or part of the constructed portion in order to make a connection or correct the position of the bridge on the footings. However, rule 11.7.3 applies.

11.2.17. A member must not contact another member except when it is in its final position and becomes part of the constructed portion.

11.2.18. A member that is not in its final position must not be supported by the constructed portion.

11.2.19. Surfaces of the constructed portion that bear on the ground must be the same surfaces that will bear on the ground in the completed bridge and, after being placed, must remain in contact with the ground for the remaining duration of timed construction and repair.

11.2.20. A builder must not support the constructed portion or a non-contiguous part of the constructed portion unless it also is supported by the ground or a temporary pier.

11.2.21. Outside the staging yard, a builder shall not contribute simultaneously to moving or supporting more than one of the following items: a member, a temporary pier, the constructed portion, or a non-contiguous part of the constructed portion. However, a builder may adjust the constructed portion as permitted by rule 11.2.16 while simultaneously supporting a member or temporary pier.

11.3. Construction Site

See the “Site Plan” on the “Site and Bridge” diagram for layout of the construction site. The host student organization lays out the site, including the one-foot by one-foot footings, before the competition. The construction site shall be laid out so that tape that designates lines is “wet” or “out of bounds.” That is, the edges of tape, not the centerlines, designate the lines shown on the “Site Plan.”

Only builders and judges are permitted within the boundaries of the construction site during timed construction. Only judges are permitted near the construction site. Spectators, including faculty advisers, must observe from areas designated by the judges and host student organization.

11.4. Start

Before construction begins, all of the following items, and nothing else, are in the staging yard: members, fasteners, tools, and temporary piers. Every member, tool, temporary pier, and fastener must be in contact with the ground. Members must not be connected or touching one another. Tools and fasteners must not be in contact with members. Tools must not be in contact with fasteners. Temporary piers must not be in contact with one another or with members, tools, or fasteners. Builders who are not barges are in the staging yards. Every barge is moored at a different moorage. Barges start without tools and fasteners, which may be passed to them by other builders after timed construction begins. Builders, including barges, are wearing personal protective equipment as well as optional clothing such as pouches.

Immediately after a tool, member, fastener or temporary pier is placed in the staging yard, the judge may inspect it for compliance with the Rules and assess appropriate penalties.

After the beginning of inspection and throughout timed construction and repairs, additional members, tools, fasteners, temporary piers, or other items shall not be brought into the construction site nor shall anything be removed. Additional builders shall not enter the construction site after the beginning of timed construction.

Timing and construction begin when one of the builders signifies that the team is ready and the judge declares the start.

11.5. Time

Time is kept from start to finish of construction. The clock will be stopped under the following conditions

- 11.5.1. if a builder or judge sees a condition that could cause injury, or
- 11.5.2. when a safety rule has been violated (see section 11.2), or
- 11.5.3. when work has been accomplished by committing an “accident.” The clock is not stopped if the “accident” does not contribute to the construction process (see section 11.7), or
- 11.5.4. if a builder or judge is injured.

Construction ceases while the clock is stopped. After the situation has been corrected, builders, tools, temporary piers, and bridge components are returned to the positions they occupied before the interruption, and the clock is restarted.

11.6. Time Limit

11.6.1. If construction time exceeds thirty minutes, it will be counted as 180 minutes for scoring. “Accidents” (section 11.7) that occur after thirty minutes will not be penalized but safety rules (section 11.2) will still be enforced. Judges will inform the team when this time limit is approached and again when it is reached.

11.6.2. If construction time exceeds 45 minutes, judges may halt construction or may move the bridge off site if it can be constructed safely. The bridge will not be eligible for awards in any category.

11.7. Accidents

In general, the clock is not stopped when an “accident” occurs. If an accident is continuous (for example, a builder who is not a barge stands in the river) it will be counted as multiple incidents. Builders involved in accidents may continue to build, and items involved in accidents must be recovered promptly and may be used.

Construction cannot depend on deliberately committing an accident. Therefore, the clock will be stopped if any work is accomplished by committing an accident. Before timed construction is resumed, builders, tools, members, temporary piers, and fasteners will be returned to the positions they occupied before the accident. Exception: Construction may proceed if it is no longer possible to hold all four bearing surfaces within the footings simultaneously. In this situation, the team captain may request that the clock be stopped in order to demonstrate the difficulty to the judge. If the judge is convinced, no additional accidents will be cited for bearing surfaces touching the ground outside the footings (rule 11.7.3), the clock will be restarted, construction will resume, and a penalty will be assessed for a two-inch violation under rule 9.2.1 (even if the bearing surfaces fall within the footings when the bridge is completed).

Types of accidents and the corresponding time penalties, which will be added to the construction time, are

11.7.1. A builder who is not a barge or that builder’s clothing touches the river or floodway, or steps outside the boundary of the construction site. Penalty is 1/2 minute (30 seconds) per incident. Exception: There is no penalty for stepping out of bounds or entering the river or floodway to retrieve an object that has been dropped, such as a member, tool, nut, bolt, or personal protective equipment.

11.7.2. A barge or a barge’s clothing touches ground. Penalty is 1/2 minute (30 seconds) per incident. Exception: There is no penalty for stepping on ground to retrieve an object that has been dropped, such as a member, tool, nut, bolt, or personal protective equipment.

11.7.3. A member, constructed portion, tool, nut, bolt, or personal protective equipment touches the river or ground outside a staging yard. Penalty is 1/4 minute (15 seconds) per incident. Exceptions: (1) There is no penalty for the constructed portion touching the ground within the one-foot by one-foot footings. (2) There is no penalty if a tool used **exclusively** for measuring touches the ground during use while being held by a builder.

11.8. Finish

Construction ends and the clock is stopped when

- the bridge has been completed by connecting all the members that were in the staging yard, and
- temporary piers and builders who are not barges are back in the staging yard, and
- every barge is moored at a moorage, with no more than one barge at each moorage, and
- every tool is in the staging yard, is held by a barge, or is in clothing worn by a barge.

Installation of decking is not included in timed construction.

After construction is finished the bridge must not be modified except as provided by section “11.9 Repairs.”

11.9. Repairs

Before the judges inspect and measure the bridge, and before the bridge is moved from the construction site, two builders will be given five minutes to inspect the bridge for construction mistakes and to plan corrective action. They must not modify the bridge and they must not touch the bridge except as necessary to use measuring devices. Following this inspection, builders will be permitted, but not required, to repair construction mistakes found by their inspectors. Repairs are made with the clock restarted and must be completed in ten minutes or less. Safety precautions (section 11.2) apply and accidents (section 11.7) are counted. The time required to make repairs (including penalties) is multiplied by 1.5. This is added to the construction time to compute total time. Judges will not inspect the completed bridge for violations of rules until after the team captain is satisfied or the time limit for repairs is reached.

12. LOAD TESTS

12.1. Safety Precautions

The judge will halt any activity that he or she considers to be hazardous.

A bridge could suddenly collapse or sway in any direction during load tests. Therefore, the number of people near the bridge while it is being tested shall be minimized. Usually, the load should be placed on the bridge by only two members of the team. Team members who are not participating in loading, faculty, advisers, and other spectators must observe from an area designated by the judges and host student organization.

While participating in load testing, competitors must wear hardhats meeting ANSI standard Z89.1, protective eyewear or safety goggles meeting ANSI standard Z87.1, gloves, and leather construction boots. This safety equipment is provided by the competitors. Judges will not permit load testing by competitors who are not wearing the specified safety equipment or are wearing it improperly.

During testing, safety supports must be in place below the decking. The safety supports shall be of sufficient height, strength, number, and extent that none of the load will fall more than approximately six inches if the bridge collapses.

Do not exceed 400 psf uniform load or 500 pounds concentrated load on the decking. Do not load on a portion of the decking that is cantilevered over its support.

When any portion of the load is on the bridge, no one is permitted to crawl, reach, or step under the bridge. If such an action is necessary, the load must first be removed.

12.2. Damage

A bridge will not be tested in a condition that compromises its strength or stability.

If a nut falls off its bolt while the bridge is being transported or prepared for load testing, or if the threads of a nut are not fully engaged, the connection will be repaired, the nut will be installed, and a penalty of two minutes will be added to construction time.

A bridge with irreparable damage that would reduce its strength or stability (such as a missing or broken member or fastener) will not be approved for load testing and is not eligible for awards in any category.

12.3. Preparation

Temporary piers are not used during load testing.

The judge designates the “A” and “B” sides of each bridge by a random process. “Left” and “right” ends are determined by facing the “A” side.

Teams must accept imperfect field conditions such as bent decking and slightly sloping floors.

12.4. Lateral Load Test

The provisions of this section are illustrated by the “Lateral Load Test” plan on the “Bridge Loading” diagram. “Sway” is translation in any horizontal direction.

The lateral load test is conducted with one unit of decking placed at the center of the bridge and approximately 75 pounds of weight on the decking near the “B” side of the bridge. This load is intended to prevent the bearing surfaces of the bridge from lifting off the ground when lateral load is applied.

A sway target is established for measurement on the “A” side of the bridge, 9’6” from the left end of the decking support surface on that side. The sway target is located at the level of the decking support surface, which is the same as the bottom of the decking. See the “Lateral Load Test” plan on the “Bridge Loading” diagram.

The two bearing surfaces on the “B” side of the bridge are prevented from sliding by horizontal restraint applied from the inside of the abutments as close as possible to the ground. This horizontal restraint does not restrain rotation of the abutments and is identical for all bridges.

Apply a fifty-pound lateral pull at the sway target and measure the sway. To pass the lateral load test, the sway must not exceed one inch.

If the bridge did not pass the lateral load test it is not approved for further testing. **Do not conduct any other load test.** Add a penalty of 900 pounds to the weight of the bridge and a penalty of thirty minutes to the construction time. Record: Aggregate deflection = sixty inches.

If the bridge passed the lateral load test, remove the load and decking, and proceed with the vertical load test.

12.5. Vertical Load Test

The provisions of this section are illustrated by the three “Vertical Load Test” elevations on the “Bridge Loading” diagram.

Safety supports are placed under the decking so that no portion of the load will drop more than approximately six inches if the bridge collapses.

Decking units are three feet long in the longitudinal (span) direction of the bridge. Place the two decking units at distances L1 and L2 measured from the left end of the decking support surface on the “A” side of the bridge to the left edges of the decking units, as shown in the “Location of Targets and Decking” plan on the “Bridge Loading” diagram. See item 4 in chapter 8 for determination of L1 and L2. Decking units are placed square with the bridge, with the main bars spanning laterally over the decking support surfaces, and centered on the designated nominal centerline (see section 9.4). Decking units must not be attached to the bridge and must not distort it (see rules 9.1.3 and 9.1.4).

Three targets are established for measuring vertical deflection. Two of the vertical deflection targets are located longitudinally at the center of the left unit of decking, on the “A” and “B” sides of the bridge, at the level of the decking. The other vertical deflection target is located longitudinally at the center of the right unit of decking, on the “A” side of the bridge, at the level of the decking. Targets may be on the decking or on the bridge.

At their discretion, judges may impose a penalty for a bridge that incorporates parts having the primary function of interfering with placement of targets or measuring devices.

Position measuring devices on the three vertical deflection targets.

Uniformly distribute 100 pounds of preload on the left decking unit and uniformly distribute 100 pounds of preload on the right decking unit. Preloads are laterally centered on the decking units. Preloads are distributed and aligned identically for every bridge.

If a contestant disturbs a measuring device after it has been initialized and before the measurement is recorded, the judge will require the team to disassemble the bridge and repeat timed construction. Scoring will be based on the larger of the two construction times but will not exceed 125% of the initial construction time.

The two steps (increments) of vertical loading produce three measurements used in scoring

- D1A = value of downward vertical deflection at left target on the “A” side that occurs during step 1 (loading the left decking unit).
- D1B = value of downward vertical deflection at left target on the “B” side that occurs during step 1 (loading the left decking unit).
- D2 = absolute value of vertical deflection at right target that occurs from the beginning of step 1 to the end of step 2 (loading the right decking unit with load from step 1 remaining in place).

Step 1

Loading the left unit and measuring deflections at those targets

- The two 100-pound preloads remain in place.
- Initialize the sway measurement.
- Initialize the measuring devices on all three vertical deflection targets or record the initial readings.
- Team members place 1150 pounds of additional load on the left decking unit. The load is laterally centered on the decking unit and is distributed over the length of the decking unit as uniformly as possible at all times during loading. Load is distributed and aligned identically for every bridge. Load shall be placed at a steady pace, without hesitation.
- As the load is being placed, observe sway and deflection. Stop loading if
 - a. sway exceeds one inch, or
 - b. deflection measurement at any of the three vertical deflection targets exceeds two inches downward from the beginning of step 1, or
 - c. decking or any part of the bridge, other than the intended bearing points, comes to bear on a safety support or the floor, or
 - d. a decking unit or some of the load falls off the bridge, or
 - e. the bridge collapses or a dangerous collapse is imminent, in the opinion of the judge.

If sway or deflection is excessive (situation a or b), the bridge is not approved for further load testing. Remove the load and **do not continue load testing**. Add an 800-pound penalty to the weight of the bridge and a penalty of thirty minutes to the construction time. Record: Aggregate deflection = sixty inches.

If the bridge fails (situation c, d, or e), it is not approved for further load testing and is not eligible for awards in any category. Remove the load and **do not continue load testing**.

If the bridge passes step 1, record the measured values D1A and D1B, which are the downward vertical deflections during step 1 of the two targets for the left decking unit.

Step 2

Loading the right unit and measuring deflection at that target

- The two preloads and the load from step 1 remain in place.
- Do **not** re-initialize the sway measurement.
- Do **not** re-initialize the measuring devices on the deflection targets.
- Team members place 1150 pounds of additional load on the right decking unit. The load is laterally centered on the decking unit and is distributed over the length of the decking unit as uniformly as possible at all times during loading. Load is distributed and aligned identically for every bridge. Load shall be placed at a steady pace, without hesitation.
- As the load is being placed, observe sway and deflection. Stop loading if
 - a. sway exceeds one inch, or
 - b. deflection measurement at any of the three vertical deflection targets exceeds two inches downward from the beginning of step 1, or
 - c. decking or any part of the bridge, other than the intended bearing points, comes to bear on a safety support or the floor, or
 - d. a decking unit or some of the load falls off the bridge, or
 - e. the bridge collapses or a dangerous collapse is imminent, in the opinion of the judge.

If sway or deflection is excessive (situation a or b), the bridge is not approved for further load testing. Remove the load and **do not continue load testing**. Add a 700-pound penalty to the weight of the bridge and a penalty of thirty minutes to the construction time. Record: Aggregate deflection = sixty inches.

If the bridge fails (situation c, d, or e), it is not approved for further load testing and is not eligible for awards in any category. Remove the load and **do not continue load testing**.

If the bridge passes step 2, record the measured value $D2$ = absolute value of vertical deflection of the target for the right unit of decking.

12.6. Unloading

If the bridge collapses during unloading, it is not eligible for awards in any category.

13. EQUIPMENT PROVIDED BY HOST

The web site <http://www.nssbc.info> has detailed descriptions and illustrations of hosting equipment. The following partial list is intended to help competitors know what to expect. Competitors should acquire similar equipment for use in practice and testing before the competition.

13.1. Floor

The surfaces on which the bridges will bear shall be solid, stable and as nearly flat and level as possible, in both the construction site and loading area.

13.2. Lateral Load Device

Capable of applying a fifty-pound force in the horizontal direction.

13.3. Equipment for Measuring Sway

Sway is horizontal translation and is measured by any accurate method. A suggested method is to suspend a plumb bob from the sway target and measure sway from a point marked on the ground.

13.4. Equipment for Measuring Deflection

Deflection is vertical translation and is measured at three points by any accurate method.

13.5. Decking

Preferred decking is steel bar grating identified as W-19-4 (1 x 1/8). The dimensions of a unit of grating are approximately 3'6" x 3'0" x 1" and the weight is approximately fifty pounds. However, the host may provide a different type of decking with approximately the same dimensions. Grating has significant bending strength only in the direction of the main bars, which are 3'6" long. The grating will be installed with the main bars perpendicular to the length of the bridge, creating a roadway that is 3'6" wide. Therefore, support for the grating is needed for the edges that are parallel to the length of the bridge but not for the edges of the grating that are perpendicular to the length.

13.6. Safety Supports

The safety supports must be used during load testing and are intended to limit the consequences of a bridge collapsing. The safety supports shall be of sufficient height, strength, number, and extent so that none of the load will fall more than approximately six inches if the bridge collapses. Safety supports may be steel, nested stacks of plastic buckets, timbers, sand bags, or masonry units.

13.7. Load

2500 pounds total. The load should be supplied in uniform pieces of size and weight that can be handled safely. When in place, the load should not provide significant stiffness in the longitudinal direction of the bridge. The recommended load consists of 25-pound lengths of 5" x 5" x 5/16" steel angle placed perpendicular to the length of the bridge. Sacks of material, containers of liquid, concrete blocks, or jacking systems could be used. Decking is not included as part of the 2500 pound load.

13.8. String

A string is stretched between the holes specified in section 9.4 in order to identify the nominal centerline of the bridge, which guides checking dimensions (rules 9.2.5 and 9.2.6) and placing the decking and load (rule 12.5).

13.9. Official Scoring Spreadsheet and Data Forms

Results will not be official until the official scoring spreadsheet is submitted to afbq@uaa.alaska.edu to report outcomes. It may be downloaded at <http://www.nssbc.info>. Judges' forms for recording data are accessed from the spreadsheet.

14. INTERPRETATION OF RULES

The web site <http://www.aisc.org/steelbridge.html> lists answers to questions about the rules. Competitors, judges, and host personnel may submit questions via a form on that web site but should **first read the previously posted clarifications and reread this *Rules* document carefully in its entirety.** Submitters' names and affiliations must accompany clarification requests and will be posted with the questions and answers. Questions must be submitted before 5:00 PM Eastern Daylight Saving Time, May 4, 2009.

15. JUDGING

The host student organization will recruit judges. Judges are empowered to halt any activity that they deem to be hazardous. Judges have full authority over conduct of the competition and interpretation of the rules. Decisions, scoring, and ranking are the sole responsibility of the judges and will be final. The host student organization will assure that the judges are fully informed of the rules and procedures, and fully equipped for their tasks. More information for host organizations and judges, including the official scoring spreadsheet, is available at <http://www.nssbc.info> and <http://www.aisc.org/steelbridge.html>.

16. APPEALS

16.1. Regional Competitions

16.1.1. At the beginning of the competition each team will identify the team member who serves as captain. The host organization will identify the regional head judge (RHJ).

16.1.2. A penalty, decision, measurement, score, or condition of competition may be appealed only by a team captain and only to the RHJ. The appeal must be made as soon as possible after the situation becomes apparent. The RHJ will not hear the appeal if he or she is approached by students other than the team captain. The RHJ will hear the appeal as soon as possible and may interrupt the competition. Participants are reminded that civility and ethical behavior are expected during the competition and particularly concerning appeals.

16.1.3. After the regional competition, the team captain has the option to appeal the decision of the RHJ by sending an e-mail message to Ms. Shanna Quinn <quinn@aisc.org> followed by a letter mailed to Ms. Quinn (AISC, Suite 700, One E. Wacker Dr., Chicago, IL 60601-2001) with a copy mailed to ASCE Student Services (ASCE, 1801 Alexander Bell Dr., Reston, VA 20191-4400). The e-mail message and letter shall include

- name of the college or university making the appeal,
- team captain's name, e-mail address, postal address, and telephone number,
- faculty adviser's name, e-mail address, postal address, and telephone number,
- brief description of the problem,
- action taken at the competition to deal with the problem,
- action that the appealing team feels should have been taken,
- data showing that the team should have qualified for national competition, and
- team captain's signature (letter only).

Appeals must be made by e-mail followed by letter. An appeal will be considered only if the e-mail is received and the letter is postmarked by 5:00 PM Eastern Daylight Saving Time on the Wednesday immediately after the regional competition. Ms. Quinn will forward the appeal to the ASCE/AISC SSBC Rules Committee for their evaluation. The Committee will not respond to an appeal until the official scoring spreadsheet for that region has been submitted by the host organization to aftbq@uaa.alaska.edu. The only redress that may be made is an invitation to participate in the national competition if the Committee is convinced that the appeal is valid and that the appealing team should have qualified for the national competition. Decisions and rankings made by regional judges will not be overturned.

16.2. National Competition

16.2.1. Judges will refuse to hear protests from a team concerning any bridge other than their own.

16.2.2. A penalty, decision, measurement, score, or condition of competition may be appealed only by a team captain and only to the station head judge (SHJ). The SHJ will not hear the appeal if he or she is approached by students other than the team captain. The appeal must be made as soon as possible after the situation becomes apparent and before the conditions at issue are changed (e.g., by further construction, loading, or disassembly of the bridge). The SHJ will hear the appeal as soon as possible and will make a ruling. The conditions at issue will not be changed during deliberation. Participants are reminded that civility and ethical behavior are expected during the competition and particularly concerning appeals.

16.2.3. After hearing the SHJ's ruling, the team captain may request a five-minute recess to discuss the issue with the team. During the recess, the conditions at issue will not be changed. Immediately after that recess, if the team has justification to contest the SHJ's ruling, the captain has the option to appeal that decision to the national head judge (NHJ). The NHJ will hear the appeal as soon as possible and will make a ruling. The NHJ may consult with the ASCE/AISC SSBC Rules Committee. The conditions at issue will not be changed during deliberation.

16.2.4. If the team has justification to contest the NHJ's ruling, the team captain has the option to appeal that decision directly to the ASCE/AISC SSBC Rules Committee within fifteen minutes after hearing the NHJ's ruling. The Committee may request information from the NHJ and SHJ but those judges will not vote on the final ruling.

16.2.5. The decision of the ASCE/AISC SSBC Rules Committee is final; there are no further appeals. However, AISC and ASCE welcome written suggestions for improving future competitions.

17. SUMMARY OF SCORING

This form summarizes chapter “7 Scoring.” Official scoring data shall be recorded on the official scoring spreadsheet that is available at <http://www.nssbc.info>. The completed official scoring spreadsheet shall be submitted to aftbq@uaa.alaska.edu.

17.1. Display (see section 7.1 - Judges shall not declare ties in display.)

- Appearance: balance, proportion, elegance, finish.
- Name of college or university on bridge in letters at least one inch high.
- Poster describing design and fabrication, no larger than 2 x 3 feet.

DISPLAY SCORE = _____

17.2. Construction Speed and Time Penalties

Construction clock time, CT	_____	minutes	
If CT ≤ 30 minutes, enter CT			
If 30 < CT ≤ 45, enter 180 (see 11.6)			_____ minutes
Time penalties during construction (see 11.7)			
11.7.1 and 2: violations _____ x 1/2	+	_____	minutes
11.7.3: violations _____ x 1/4	+	_____	minutes
Repair time (see 11.9) _____ x 1.5	+	_____	minutes
Time penalties during repair (see 11.7, 11.9)			
11.7.1 and 2: violations _____ x 1/2 x 1.5	+	_____	minutes
11.7.3: violations _____ x 1/4 x 1.5	+	_____	minutes
Time penalty, damage (see 12.2)	+	_____	minutes
Time penalty, load tests, 30 min (see 12.4 and 12.5)	+	_____	minutes
TOTAL TIME =			_____ minutes
			Lowest total wins.

17.3. Construction Economy

Number of builders, including barges	(_____	builders	
Total time (part 17.2)	x _____	minutes	
	x _____	50)
Number or temporary piers: minimum of 1 (see 7.3)	+ (_____		
	x _____	50)
CONSTRUCTION COST: C _c =			_____ thousand \$
			Lowest cost wins.

17.4. Lightness and Weight Penalties

Bridge weight	_____	pounds
Weight penalties,		
"7.1 Display" (30, 50, or 80)	+	_____ pounds
"9.2 Usability"		
Rules violated $\leq \frac{1}{2}$ inch _____ x 50	+	_____ pounds
Rules violated $\frac{1}{2}$ - 1 inch _____ x 150	+	_____ pounds
Rules violated 1 - 2 inch _____ x 300	+	_____ pounds
"9.3 Member-to-member Connections"		
Number of violations _____ x 25	+	_____ pounds
"9.4 Centerline" (100)	+	_____ pounds
"10.2 Durability & Constructability"		
Number of violations _____ x 25	+	_____ pounds
"12.4 and .5 Lateral Load and Vertical Load" (900, 800 or 700)	+	_____ pounds
	TOTAL WEIGHT =	_____ pounds
		Lowest weight wins.

17.5. Stiffness

AGGREGATE DEFLECTION: $D1A + D1B + D2 =$ _____ inches
 Lowest deflection wins.

17.6. Structural Efficiency

Total weight (part 17.4)	(_____ pounds
	x _____)
Aggregate deflection (part 17.5)	+ (_____ inches
	x _____)

STRUCTURAL COST: $C_s =$ _____ thousand \$
 Lowest cost wins.

17.7. Overall Performance

C_c (from part 17.3) _____ + C_s (from part 17.6) _____ = _____
 Lowest total wins.

17.8. Ranks (Display is the tie-breaker for all categories)

A bridge will not be ranked if it was submitted by a student organization that is not in good standing with ASCE or is not assigned to this region, or if the bridge was not approved for construction or load testing, or failed in load testing.

Display _____	Construction Speed _____	Lightness _____
Stiffness _____	Construction Economy _____	Structural Efficiency _____
Overall Performance _____		

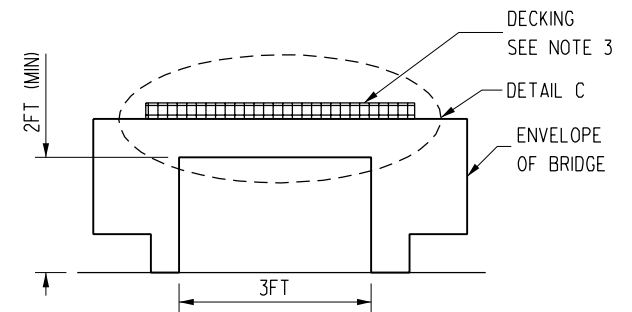
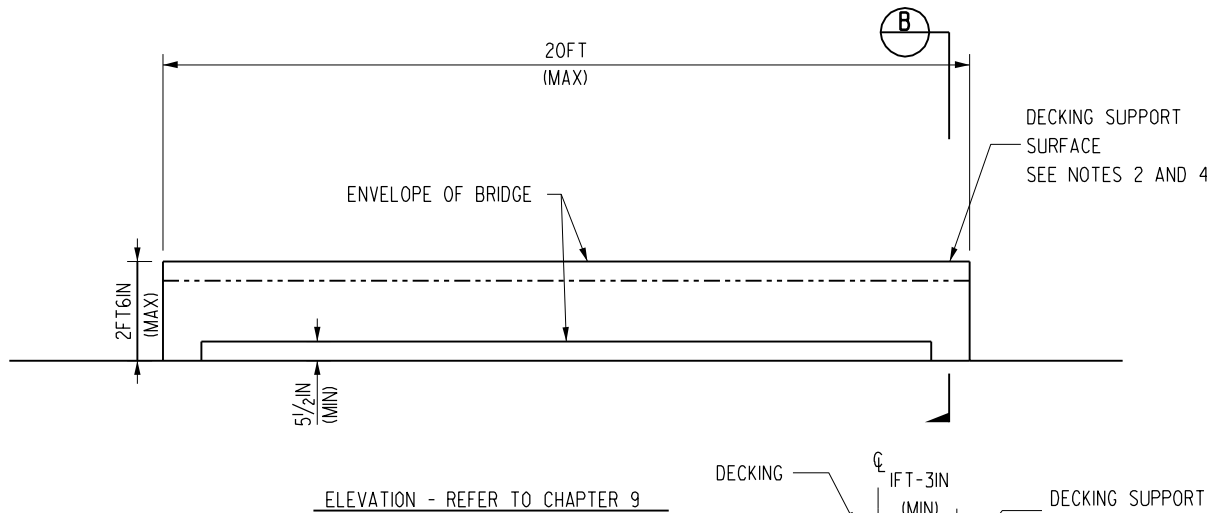
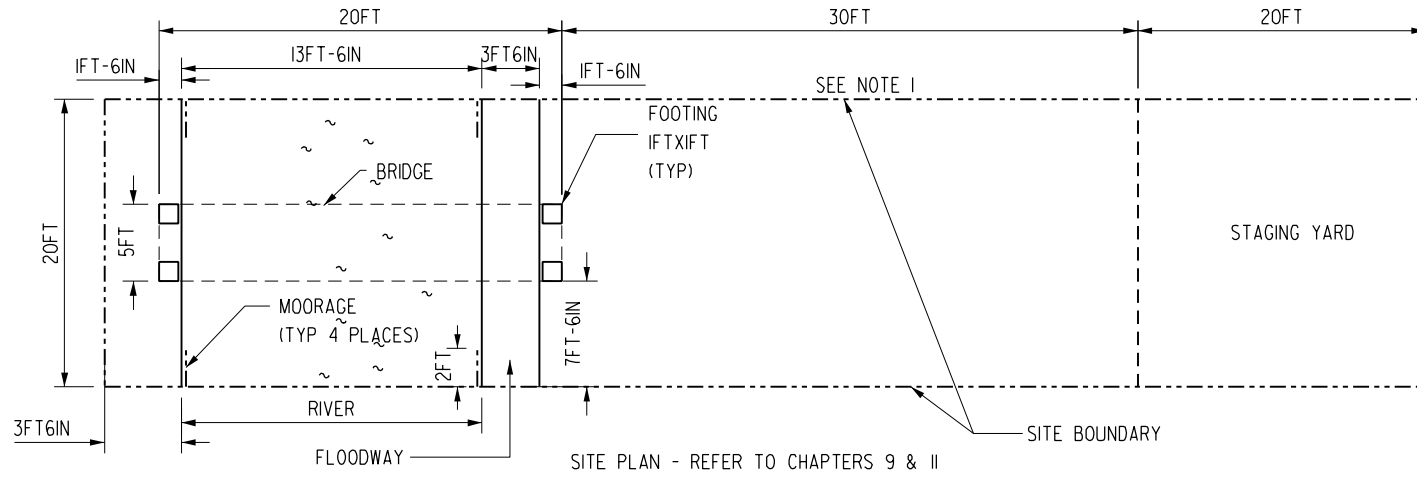

B END VIEW
NO SCALE

C DECKING SUPPORT
NO SCALE

NOTES:

1. LENGTH CAN BE ADJUSTED TO FIT SITE CONDITIONS.
2. NO PART OF THE BRIDGE SHALL EXTEND ABOVE DECKING SUPPORT SURFACES.
3. BRIDGE SHALL ACCOMODATE DECKING THROUGHOUT OVERALL LENGTH OF THE BRIDGE IN ACCORDANCE WITH RULE 9.2.4.
4. NO PART OF BRIDGE SHALL EXTEND BEYOND DECKING SUPPORT SURFACE (AT BOTH ENDS).

REV	DATE	BY	APP	REG NO	EXPIRES	SEAL HOLDER	DESCRIPTION
A	6-27-08						2009 SSBC RULES

DESIGNED BY
F. HATFIELD
DRAWN BY
D. SEPULVEDA
CHECKED BY
RULES COMM.
IN CHARGE
F. ROSENBERG
DATE
6-27-2008

ASCE - AISC
STUDENT STEEL BRIDGE CONTEST

ASCE  **AMERICAN SOCIETY OF CIVIL ENGINEERS**

SUBMITTED _____
APPROVED _____

SITE AND BRIDGE
DIAGRAM

CONTRACT NO	
DRAWING NO	EXHIBIT 1
SCALE	AS SHOWN
SHEET NO	

DATE: 6/27/08 BY: F. ROSENBERG

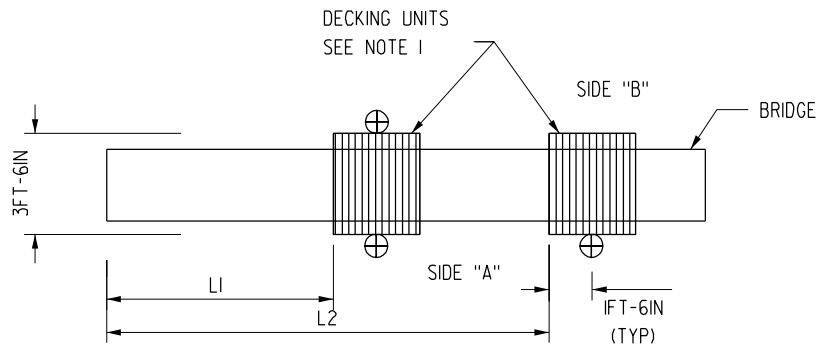

A LOCATIONS OF TARGETS AND DECKING - PLAN
REFER TO CHAPTER 12, SECTIONS 3 & 5

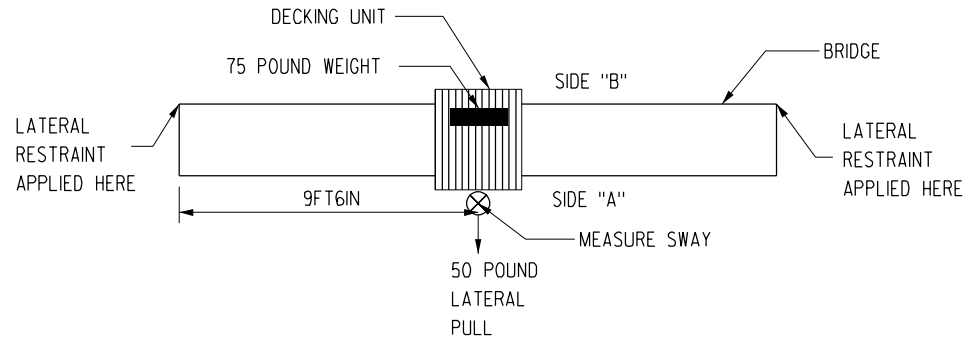

B LATERAL LOAD TEST - PLAN
CHAPTER 12, SECTIONS 3 & 4

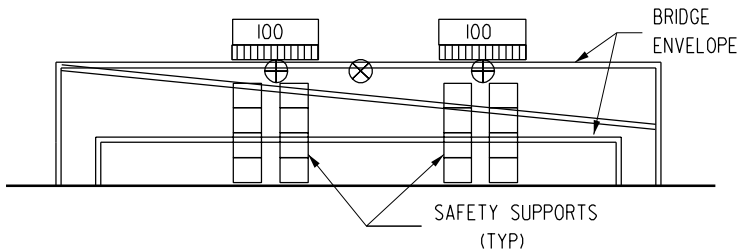

0 VERTICAL LOAD TEST - PRELOAD
REFER TO NOTES DURING LOADING PROCESS

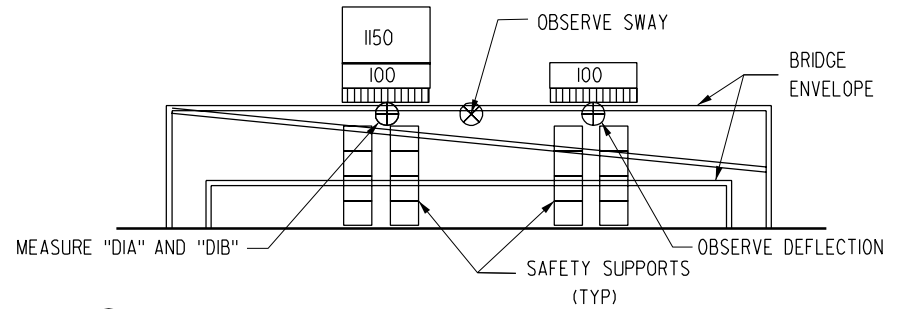

1 VERTICAL LOAD TEST - STEP 1
REFER TO NOTES DURING LOADING PROCESS

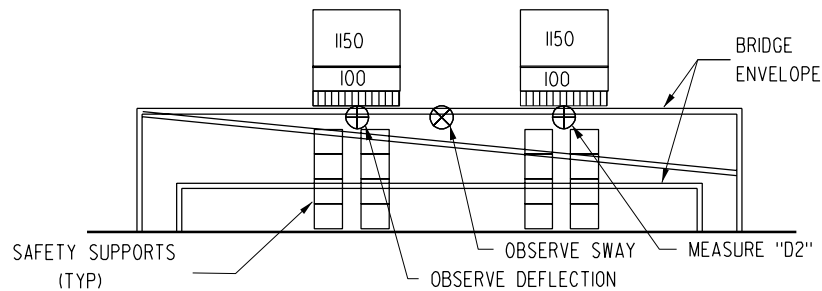

2 VERTICAL LOAD TEST - STEP 2
REFER TO NOTES DURING LOADING PROCESS

LEGEND

- ⊕ TARGETS FOR MEASURING VERTICAL DEFLECTION TO BE PLACED LONGITUDINALLY AT THE CENTER OF THE DECKING UNITS
- ⊗ TARGET FOR MEASURING SWAY

NOTES

1. THE LOAD IS LATERALLY CENTERED ON THE DECKING UNIT AND DISTRIBUTED OVER THE LENGTH OF THE DECKING UNIT AS UNIFORMLY AS POSSIBLE AT ALL TIMES DURING LOADING.
2. OBSERVE ALL VERTICAL TARGETS ON EACH SIDE OF THE BRIDGE FOR DEFLECTION.
3. LOADING TERMINATES IF DEFLECTION AT ANY OF THE VERTICAL DEFLECTION TARGETS EXCEEDS 2 INCHES DURING STEP 1 AND STEP 2.
4. LOADING TERMINATES IF SWAY AT SWAY TARGET EXCEEDS 1" DURING STEP 1 AND STEP 2.
5. SAFETY SUPPORT TO BE IN PLACE AT ALL TIMES DURING LOADING.
6. BRIDGE TO BE UNLOADED IN THE REVERSE ORDER OF LOADING.
7. ALL LOADING SAFETY PROCEDURES TO BE FOLLOWED.

REV	DATE	BY	APP	REG NO	EXPIRES	SEAL HOLDER	DESCRIPTION
A	6-27-08						2009 SSBC RULES

DESIGNED BY F. HATFIELD
DRAWN BY D. SEPULVEDA
CHECKED BY RULES COMM.
IN CHARGE F. ROSENBERG
DATE 6-27-2008

ASCE - AISC
STUDENT STEEL BRIDGE CONTEST

ASCE **AMERICAN SOCIETY OF CIVIL ENGINEERS**

CONTRACT NO. _____
DRAWING NO. **EXHIBIT 2** REV. _____
SCALE **AS SHOWN**
SHEET NO. _____

BRIDGE LOADING
DIAGRAM

SUBMITTED _____
APPROVED _____

DATE PLOTTED BY: 11/15/08

