

THE OBJECTIVES

To develop a software solution* capable of optimizing the heat treatment process at A. Finkl & Sons.

The software must be capable of:

- Maximizing batch size
- Outputting the best loading pattern based on:
 - Available parts (in heat treat area)
 - Work order priority
- Functioning with Finkl's work order database*
- Utilizing files output by popular CAD packages such as ProEngineer or UGS*
- Accepting upgrades developed by future IPRO teams

*DENOTES CURRENT SEMESTER OBJECTIVE

THE OBSTACLES

The IPRO 304-A Team consists of seven members, only one of which had ANY experience with software development. As such, a major learning curve forced Team Members to expand their knowledge of mechanical/electrical/materials engineering to include:

- The software design/engineering process
- How to create a software build environment
- Computer Programming using:
 - Microsoft Visual Studio
 - Qt
 - GUI
- Software Testing
- Software license limitations

THE IPRO 304-A TEAM

(in alphabetical order)

- Vlad Antal
- Steven Banaska
- Hussain Biyawerwala
- John Groszko
- Ryan Jay
- Kyle Koning
- Sangwook Lee

Advisors

(in alphabetical order)

- William Maurer
- Sheldon Mostovoy

Sponsor



A. Finkl & Sons Co.

HEAT TREAT



AN INFORMATION TOOL FOR THE MEALS INDUSTRY



IPRO 304-A

FALL 2007

THE SOLUTION

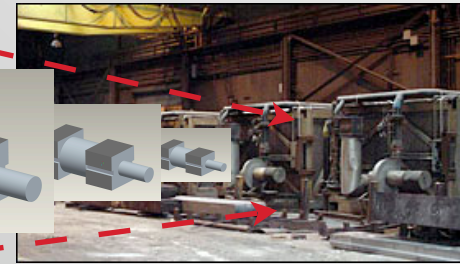
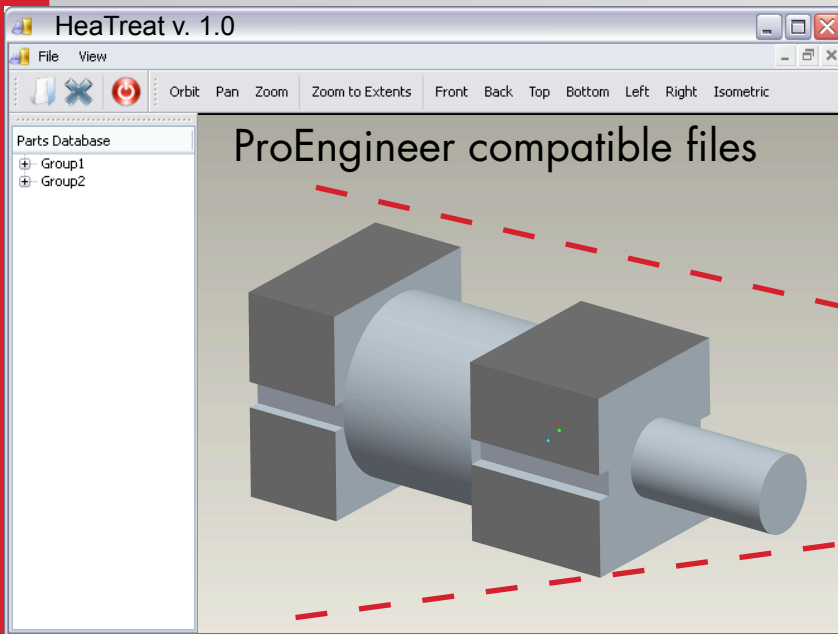

Heat Treatment Furnaces at A. Finkl & Sons

Accomplishments

- Development of a robust program suited for the needs of A. Finkl & Sons using industry-capable components currently utilized by top CAD suites:
 - HOOPS 3D Application Framework
 - 3D ACIS Modeler
- Completion of an extensive parts template portfolio for real Finkl products, compatible with HeaTreat and created in ProEngineer

HeaTreat -the software solution created by IPRO 304-A represents the first major step toward the achievement of all the project objectives. The HeaTreat environment, seen above, utilizes fully solid 3D modeling with a simple, but effective user interface. HeaTreat is fully compatible with ProEngineer files and the Finkl work order database. Since the HeaTreat environment utilizes fully solid modeling and part files compatible with ProEngineer, the template portfolio of actual Finkl parts is ready for use and will be functional for years to come. Though current functions are limited to basic part views, a full toolbox of manipulations and abilities is on the way. The robust program engine utilized by IPRO 304-A has laid the foundation for many future updates to be created by IPRO teams.

THE FUTURE

- Develop a loading algorithm (to power automatic placement) based on the principle of filling the furnace with the maximum volume of parts
- Add thermodynamic modeling to incorporate heat capacity and localized heating into automatic placement function
- Simplify program and/or placement output for use with a handheld device for Heat Treatment Foreman and Furnace Loaders