

Advisors

Dietmar Rempfer

Sheldon Mostovoy

Mechanical team

Celeste Wegrzyn

(Project lead)

Sara Claxton

Greg Herbert

Ross Allen

Electrical team

Dan Schaffer

(Team lead)

Luis Adrianzen

Matthew Gaylord

Chris Antonio

Mark Callan

Patrick Tagny Diesse

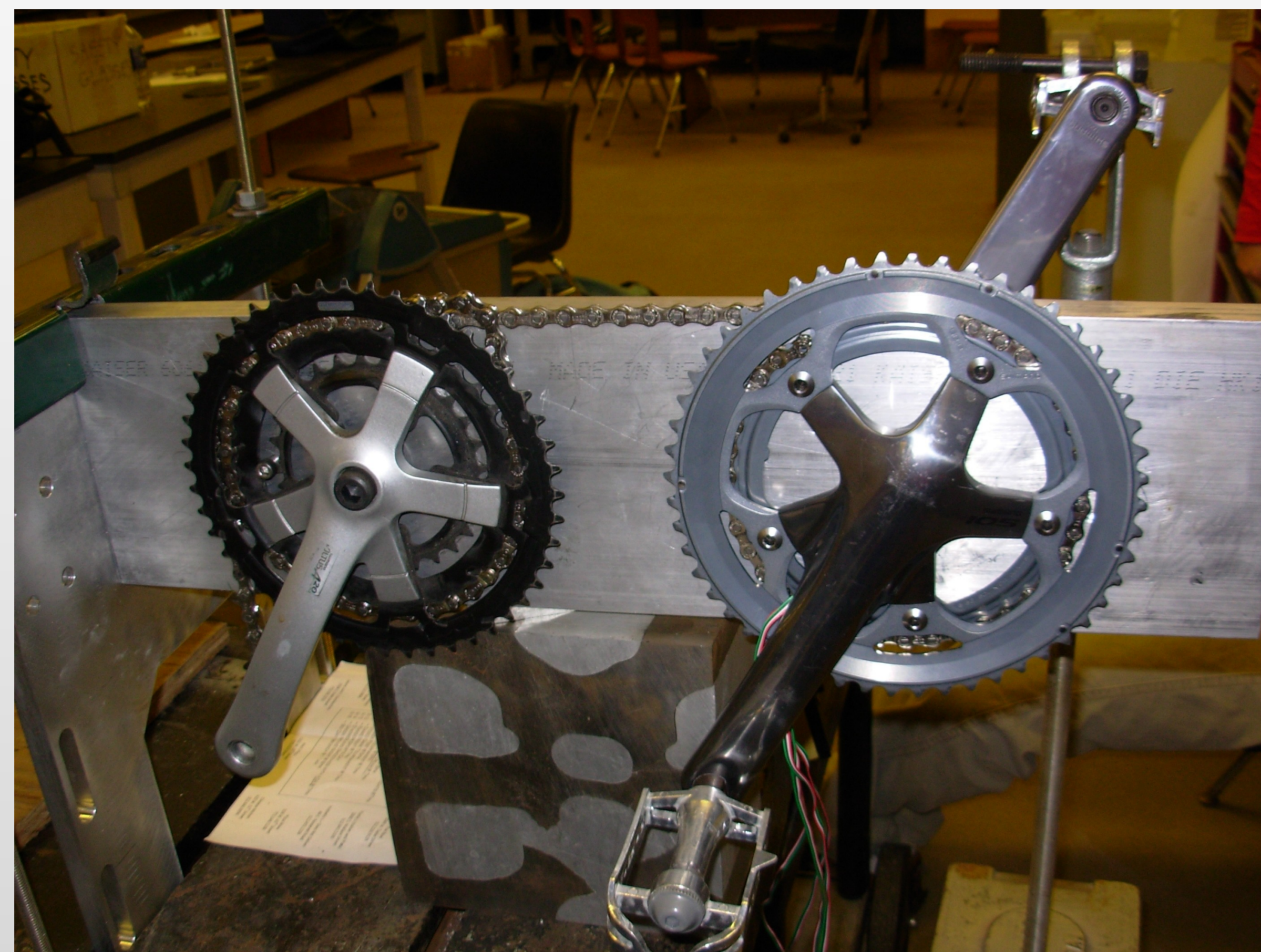

Problem

1. Available power measurement devices are expensive.
2. Solution MUST retrofit to existing cranksets.

Background

Current available systems on the market:

- Crankset (strain in crankset)
- Free hub (strain in rear wheel)
- Chain (vibration and speed of chain)
- Opposing force (gravity, drag, acceleration, & wind velocity)

Pricing of these systems runs anywhere from sev-



The Powertap SL 2.4 shown here for example is priced from \$1500 up to \$2000. And as we can see, it is not adaptable to a general crankset as the one shown above.

Some mechanical testing results

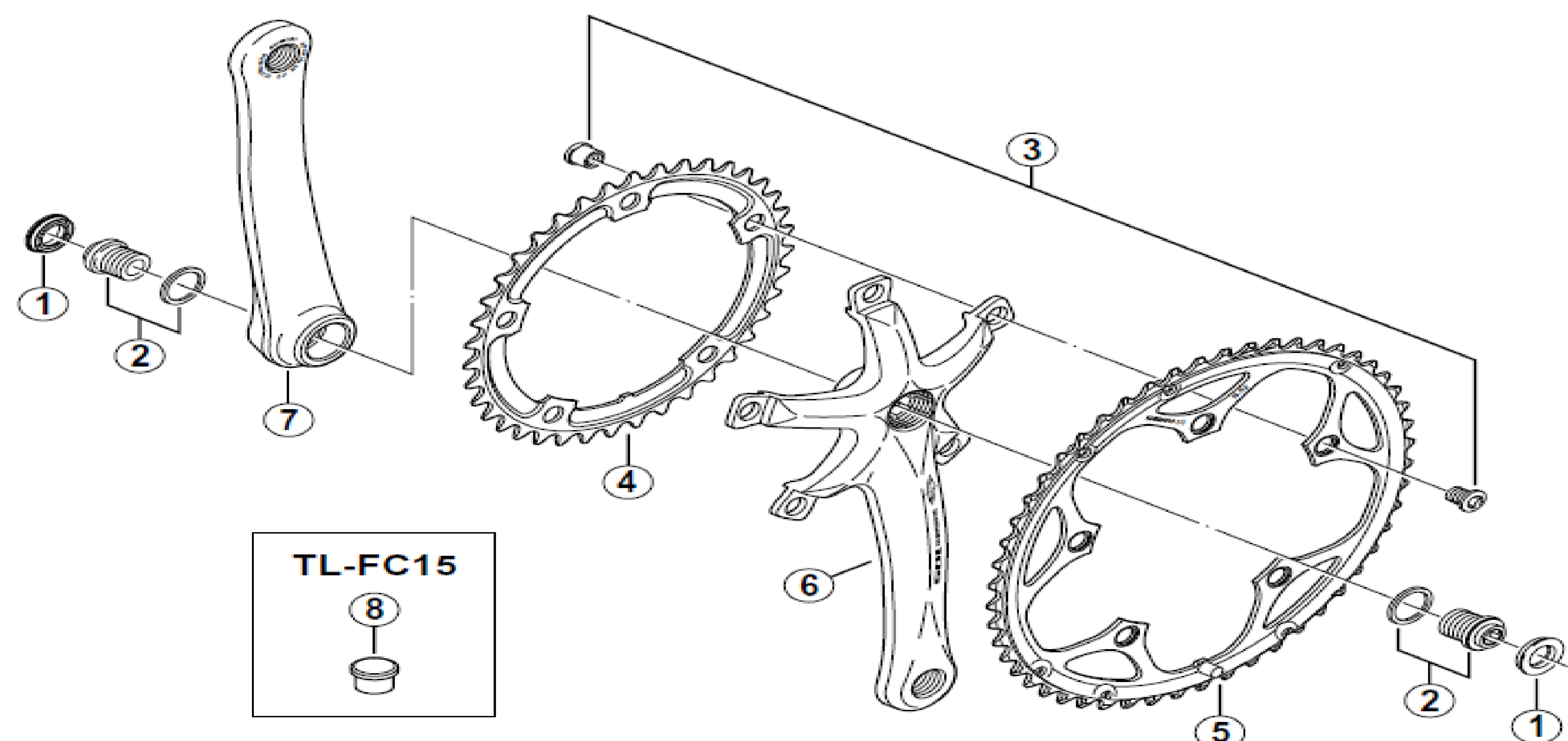
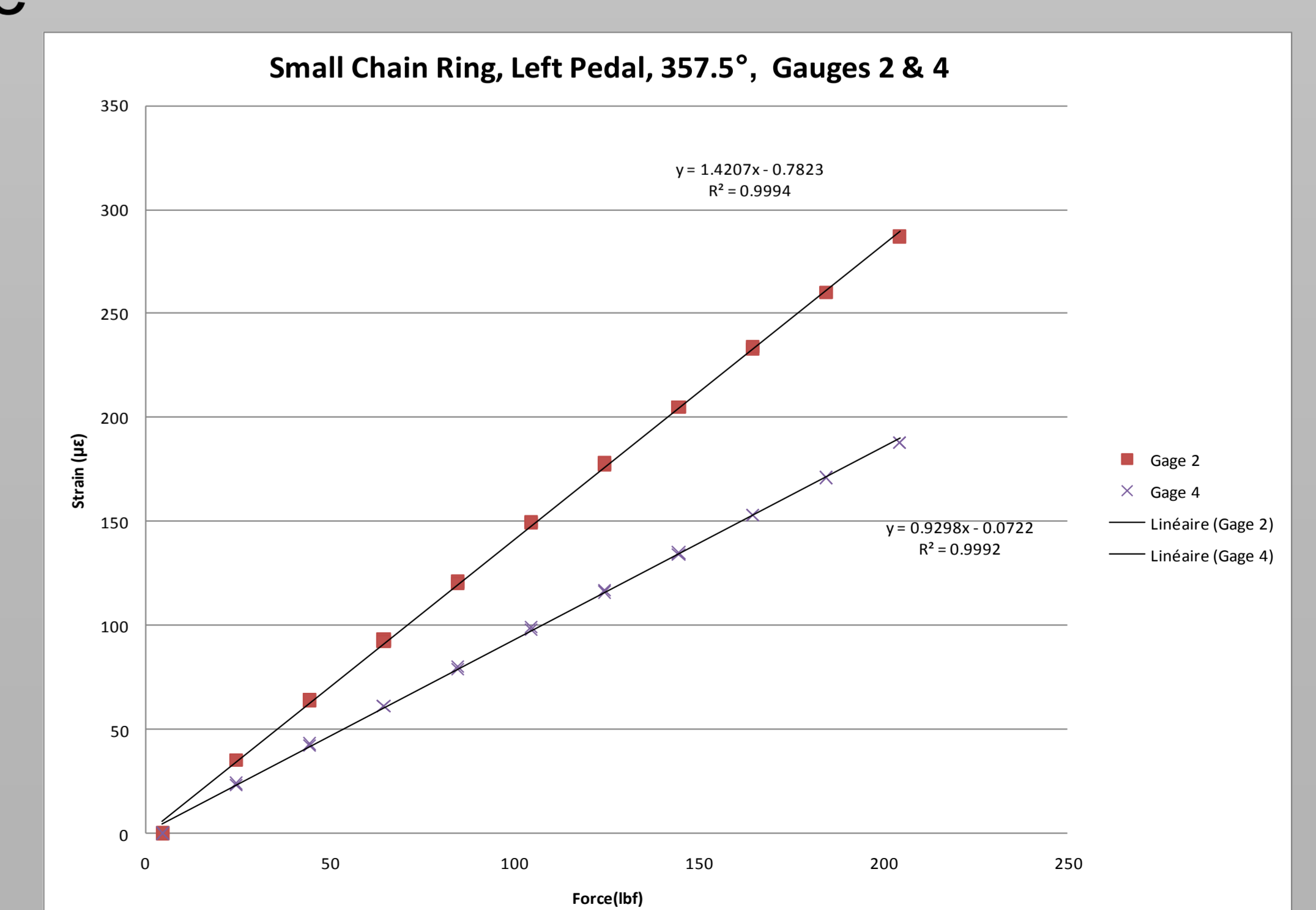
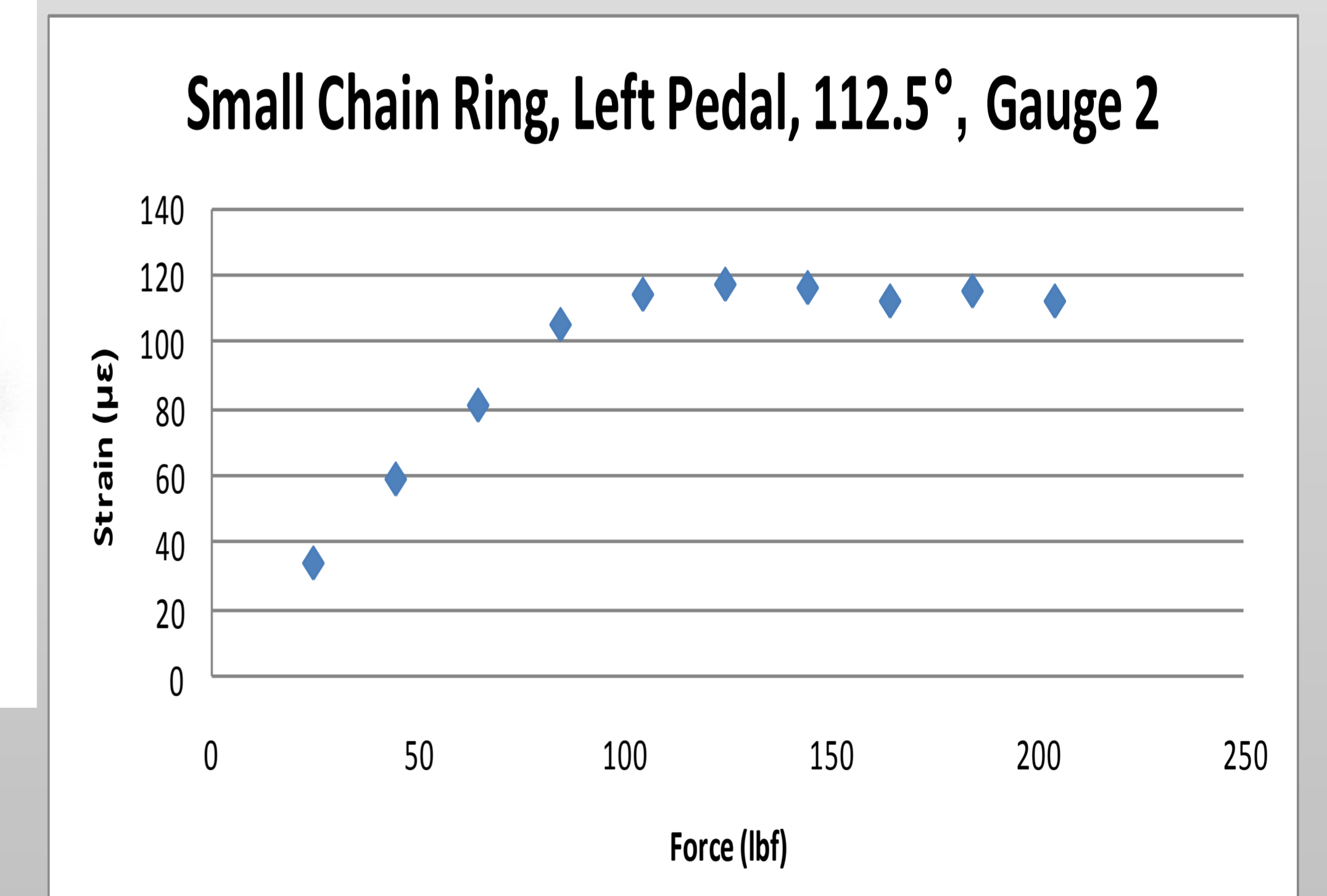
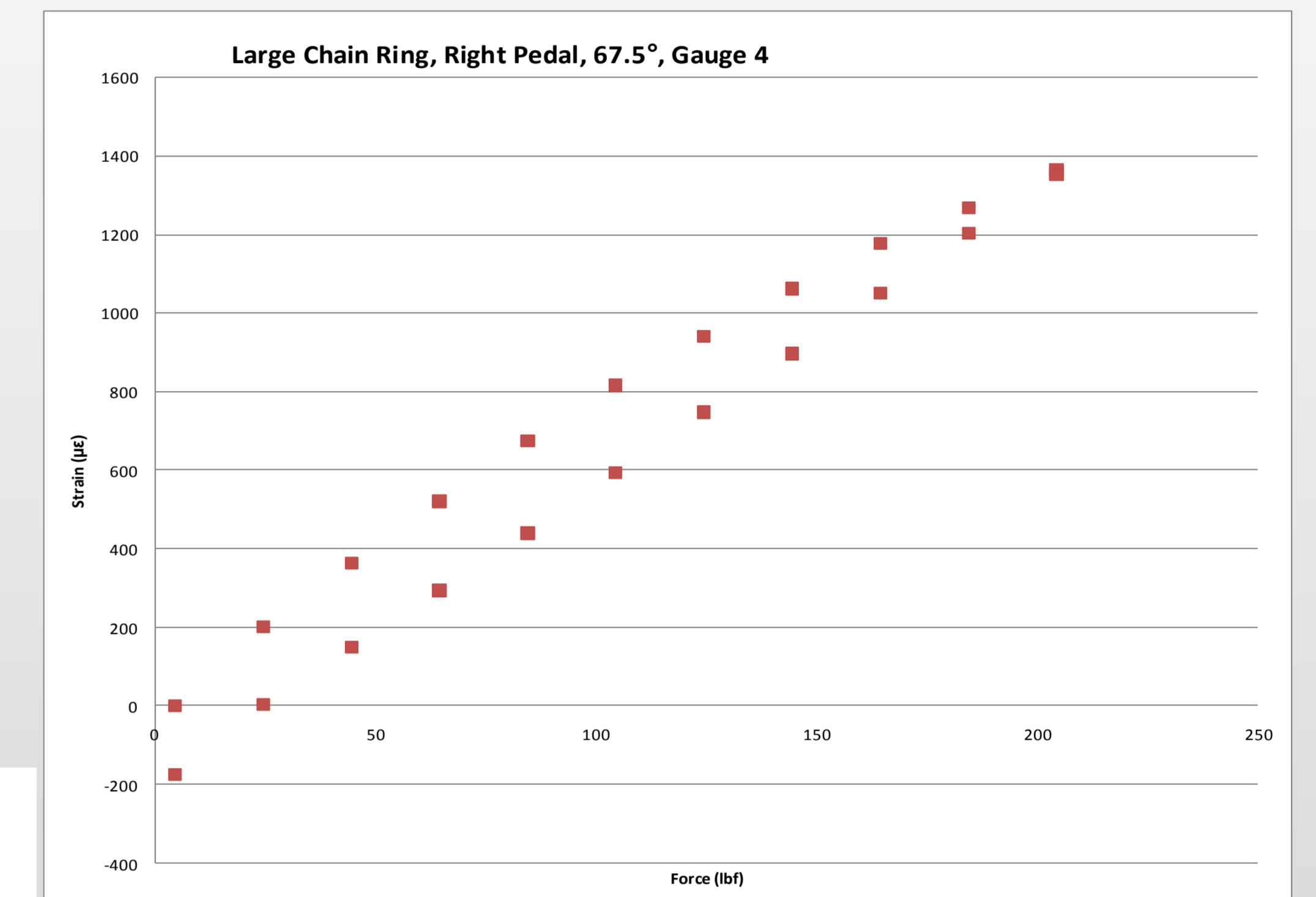

Objectives

- Miniaturize existing electrical system
- Update existing code for the power calculation program
- Obtain strain gauge coefficients
- Create a housing and mounting system
- Perform dynamic testing
- Minimize costs and power consumption

Methodology

Electrical Team

- Replace chip components with smaller and more efficient ones
- Remove redundant components
- Update code to automatically power down the system and adjust the torque formula upon startup

Mechanical Team

- Modify the test fixture containing the crankset to be perpendicular to its initial position
- Recalculate torque coefficients
- Create a universal housing and mounting system for the chip
- Perform road testing of the system

Electrical design

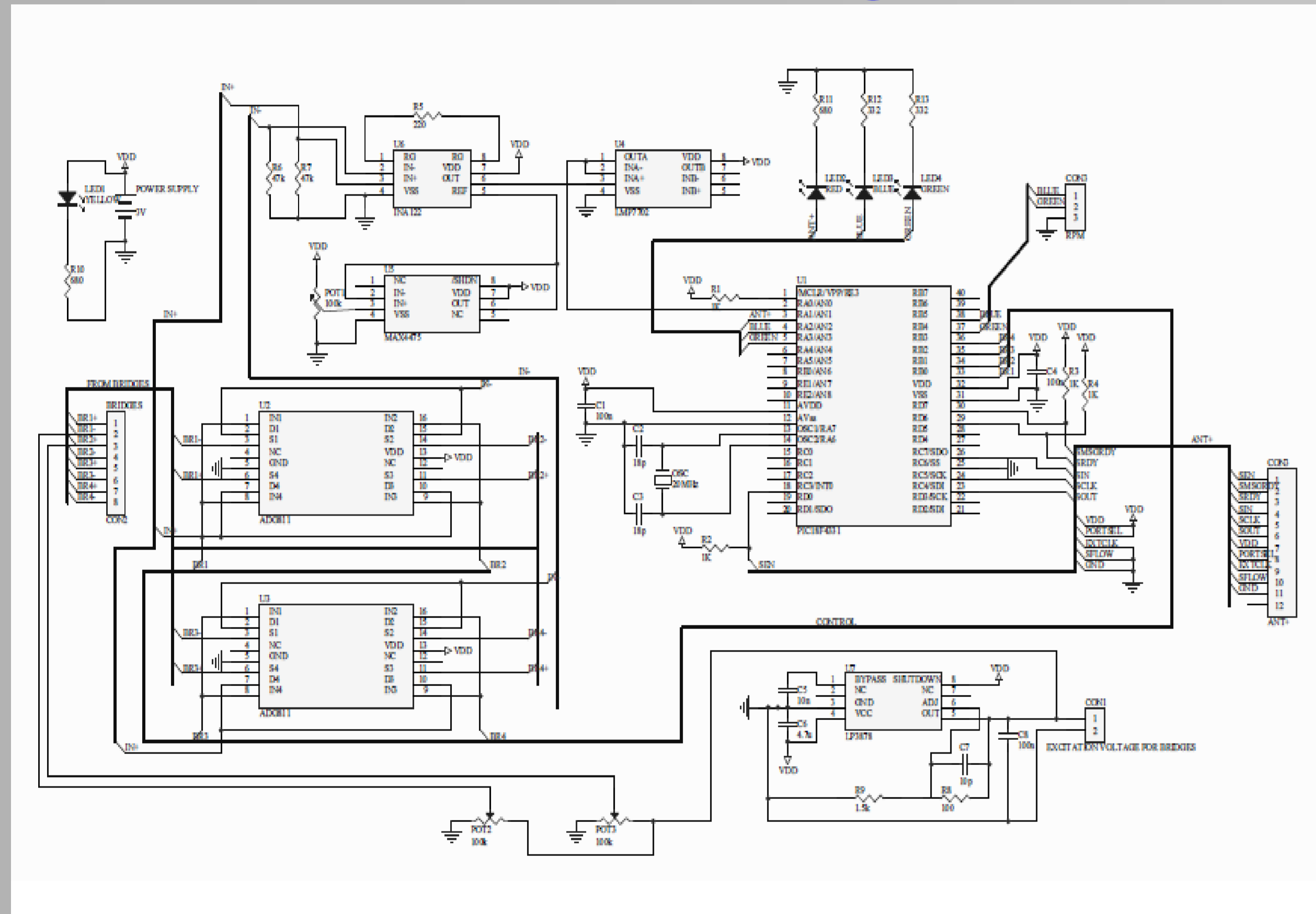

Obstacles

Electrical Team

- Miniaturization of the board to fit on the crankset
- Source code needs to take into consideration the change of angle to compute power output accordingly.
- Ways to increase power efficiency

Mechanical Team

- Attachment of all components to crank
- Finding a way to obtain a bicycle
- Integration of mechanical and electrical designs
- Performing road testing in a short amount of time

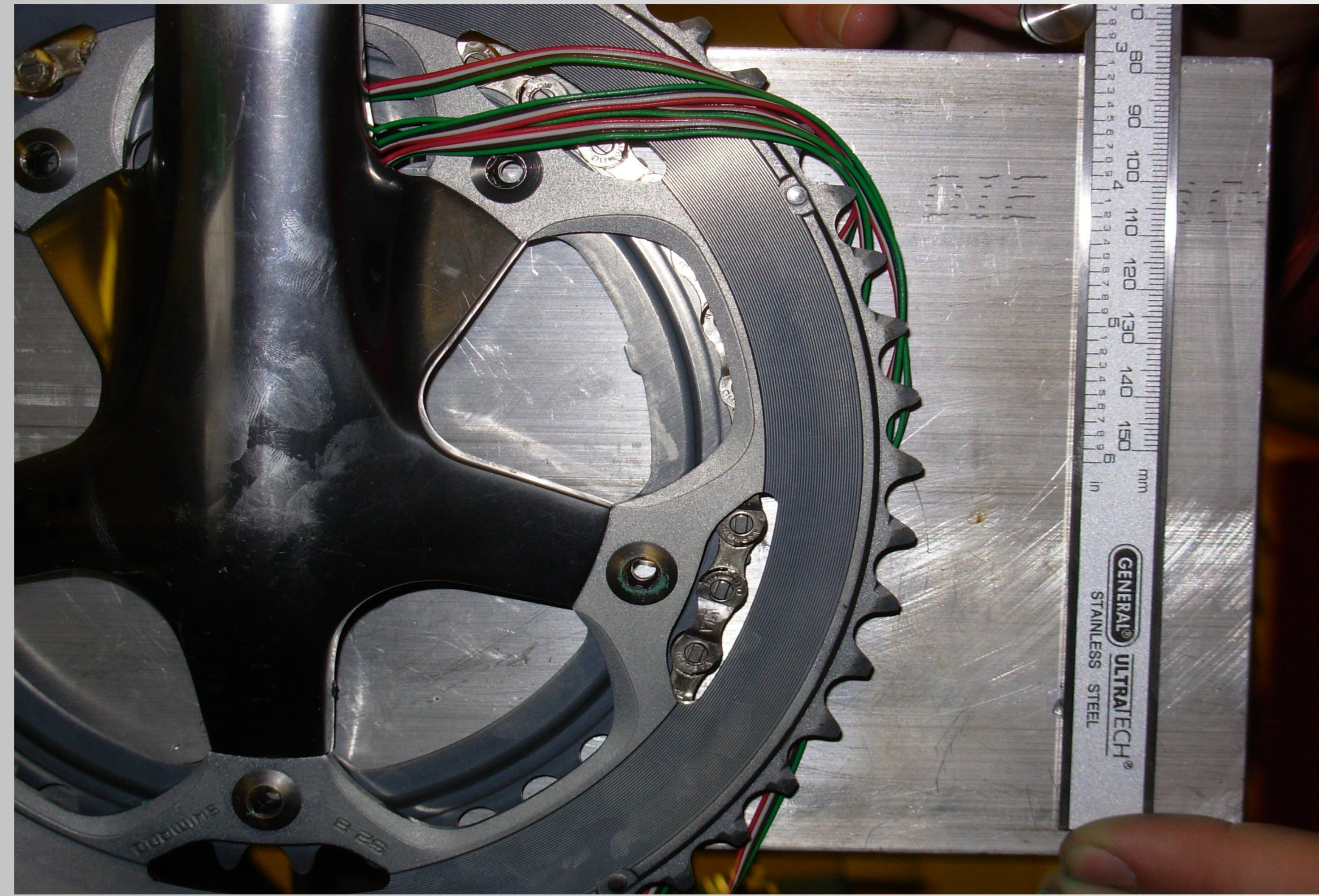

Results/Conclusions

Electrical Team

- Power efficiency and size have been improved
- Circuit virtually laid out on a PCB board.
- PCB board manufactured and electrical components integrated onto board.
- Coefficients uploaded to the program and power calculations written for one over 8 angles.

Mechanical Team

- New testing procedure used to test crank set at proper chain orientation.
- New crank attachment procedure developed to eliminate testing errors
- Coefficients for weight-strain relationship calculated.
- Circuit housing designed and integrated onto crank set

Housing design



Bike purchased at:

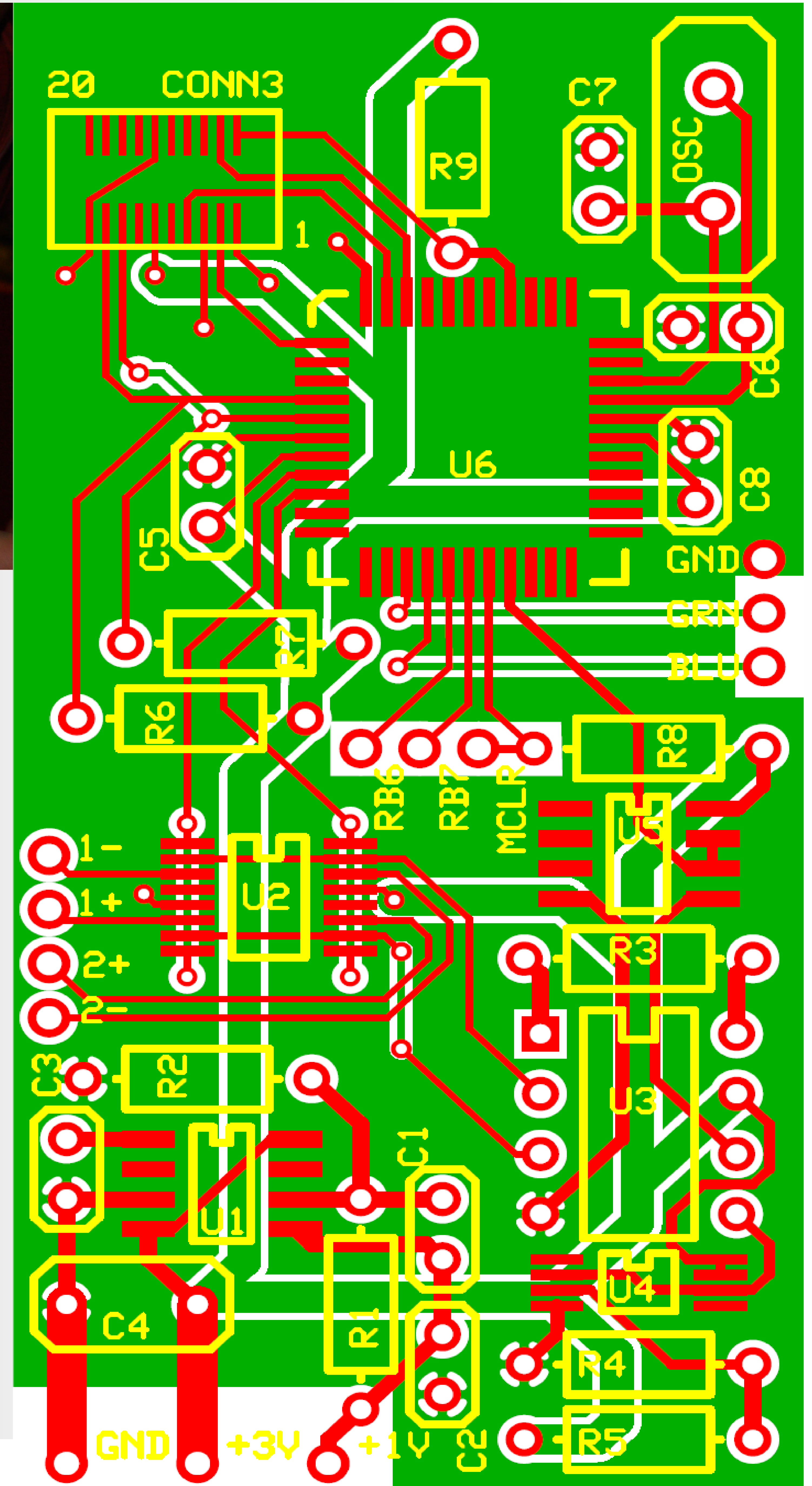

ILLINOIS INSTITUTE OF TECHNOLOGY

3300 S. Federal St.
Chicago, IL 60616www.iit.edu
Contact Info:
rempfer@iit.edu