

I PRO 335
GREEN BUILDING DESIGN CONCEPT & INTEGRATION

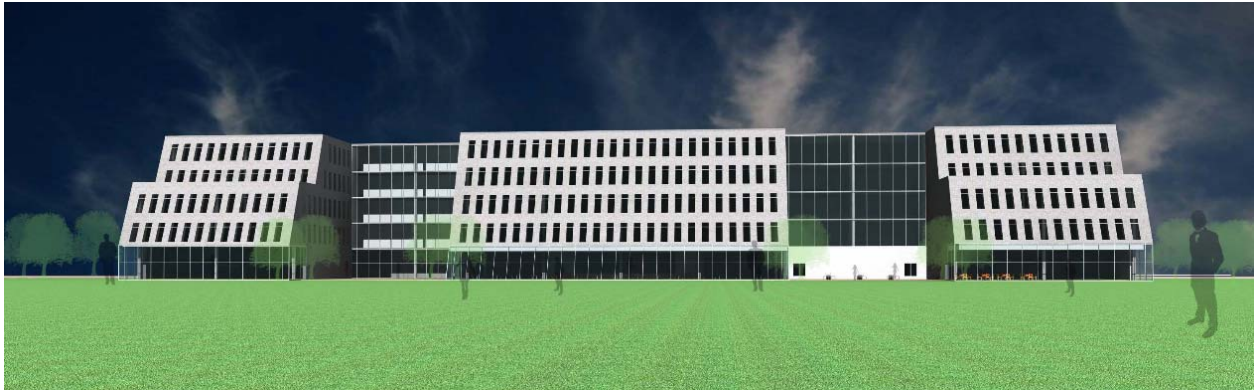

Final Report
December 4th, 2009

Executive Summary

The members of IPRO 335 have taken on the task and successfully completed a preliminary design of a green building which achieves a model for sustainable design and achieves a LEED platinum rating. The building calls for a five story high rise with retail space on the first floor and offices on the upper four floors. Using architectural design methods and increasing the performance of building systems through alternative means of energy, a successful green building design is achieved which is both architecturally appealing and has sound engineering. Through effective communication skills and teamwork, the members of IPRO 335 were able to deliver a realistic preliminary model of green building design concepts and integration.

Purpose:

Green Building design is becoming a vast topic in today's world. As times change, and energy sources become limited and more expensive, we need to find more ways to conserve energy. Green building design is also a way to create a better living and working environment for the occupants while reducing the environmental impact of the building. This IPRO's main goal was to design and implement alternative energy sources into a building in order to obtain LEED Platinum rating while creating a better working environment for its occupants.

Objective:

The objective of the project was to design a five story commercial mixed-use building. The building contains retail stores on the first level, and office spaces on the remaining upper levels. The total foot print area is approximately 49,000 square feet. The building will be constructed with prefabricated columns, beams, floors, and wall panels from The Spancrete Group, Inc. Major sections of the design phase included the use of architectural planning to reduce the building impact as well as the design of major alternative energy systems and water reuse. Also a building energy model that assesses the energy use and the design of structural members to ensure the integrity of the building were incorporated. It was the team's intention to develop an architecturally feasible building schematic which incorporates energy saving features. Using this schematic, research was implemented and the building was designed using as many of the green concepts that are available and functional with respect to the site, practicality, and design knowledge. A goal to have a LEED certified building with a Platinum rating was given to the team members. Finally an estimate of the energy saved, as well as potential money saved through the design is to be provided.

Organization and Approach

The team is divided into two groups among engineers and architects. Amongst the engineers and architects, each person is paired together for a specific research and design phase; an attempt was made to mix and match engineers and architects for more diversity and exchange of ideas. Each team has researched and developed designs for different alternative energy sources or methods used in green building as well as structural and architectural designs; energy systems include: geothermal, solar, wind, and water reuse. Following this, the team has implemented these developments into the design of the building. The architects have created a design that is both suitable and feasible for green methods and allows for maximum LEED points. Within this design, the engineers have incorporated their findings and calculations in order to maximize the potential green building features. Each source of alternative energy or method of green building used will be tested through calculation and research. Even though sub-groups have been made for specific tasks everyone was encouraged and took part in all aspects of the design process. Immense concentration on team work and communication, particularly between the engineer/architect segregation, has been achieved and resulted in positive results for the project. (See Appendix for Team Structure and breakdown)

Analysis and Findings

The following is a breakdown of the main divisions of the project. These divisions consist of structural design, wind energy systems design, geothermal systems design, solar energy systems design, rainwater reuse, architectural design, and a building energy model. A LEED checklist was also put together in order to show that this building design can be LEED platinum certified. These topics were researched and designed in more detail in order to show a building design which is sustainable and practical in today's environment.

Architectural Design

The plan of the building was one that was shaped from the original given footprint of the project, which was very long and narrow. The Architects decided to face one of the longest façades to the south so that the reception of solar light would be the highest. The window area on the south façade was designed to have the optimal amount of natural day lighting enter the building as required by LEED. The windows are punched openings rather than a standard curtain wall to allow for the use of the Spancrete panels for the exterior walls and to increase the insulation value of the building. The building has several step backs which allow for more daylight and space for green roofs. The longitudinal south façade is covered with photovoltaic panels and is designed at an angle to maximize the absorption of sunlight on the panels. Close to the entire area of the roof is used to collect rainwater to supply some areas of the building

with gray water. The other striking feature on the roof is the array of wind turbines, which align with the column grid and create linearity from a distance. The north, east and west façades have fewer openings than the south to keep the building better insulated. (See Appendix for Renderings)

Structural Design

As the architects were completing the final design of the building, the structural group researched design codes referenced in the Chicago Building Code (CBC). Using the CBC, both dead load and live load cases were found for each floor of the building. Research on the sizing of the beams, columns, and floor slabs was done using the D/E (Design and Engineering) handbook provided on the Spancrete website. The website was a useful tool in providing a visual representation of what different sections would look like. After consulting the CBC and the Spancrete design handbook it was decided to design a 1-way flooring system with 40 ft bays. A meeting was scheduled with a Spancrete representative, who was a structural engineer, to help analyze the design and provided information on costs as well as design solutions. After consulting with a Structural Engineer from Spancrete, it was determined that the original design was adequate. However, some changes to the building were made in order to decrease the overall cost. It was decided to replace the beams and columns on the East and West sides of the building with a load bearing wall which will help reduce costs. (See Appendix for design details.)

Wind Energy Systems

The team began this semester researching wind technology and the various types of wind turbines. Wind data available online was gathered to determine the average wind speed for the site. Based on the data collected, the average wind speed for the site was between 3.3 and 4.6 m/s. After some preliminary calculations, assuming the average to be 4 m/s, it was determined that using wind as a main source of energy was not practical with the site conditions and current technology. Despite these facts it was concluded wind energy could still provide a small portion of the energy demand as well as be a highly visible display of the team's desire to build a "green" and efficient building. The next step was to find a turbine that would be able to perform at a high enough level based on site conditions. Vertical axis wind turbines were determined to be the best option and several manufacturers were compared. The final choice was based on the economics of energy production, return on investment period, and visual appearance of the turbine. The final building design features; (11) Urban Green Energy 4 kW vertical axis wind turbines mounted on the roof. These units will have a breakeven point of about 18 years assuming the owner can receive federal and state tax incentives. This system will provide approximately 44,000 kWh/year, which represents about 1% of the buildings

energy demand. The team can also advertise that about 1/3 of the retail lighting is powered by wind energy which will be an incentive for businesses to occupy the building.

Geothermal Systems

The Geothermal System group was in charge of designing a system, which utilizes the earth's core temperature to decrease the energy consumption required to condition the air in the building. The group had to accomplish a wide variety of tasks such as how ground loop geothermal systems function, how to incorporate the system into the building, and basic design of the system to fit our mixed-use building. The group relied heavily on research and case studies, as no members of the IPRO team had experience in geothermal design. Two types of software to help with the design were found and utilized. Ground Loop Design 2009 was used to derive a basic geothermal design. The second piece of software that was incorporated was System Analyzer by Trane; it was used to calculate the heating and cooling loads for a building based on several factors including building occupancy and duration of occupancy, location and climate, building materials and enclosure, and preliminary system information. Through research, analysis of case studies, and use of the aforementioned software, the group was able to design a basic system which uses Florida Heat Pumps model ES 070. Each unit has a cooling capacity of 5221.2 kBtu/hr and a heating capacity of 5029.4 kBtu/hr, where the entire building would use a total of 76 units distributed throughout. The piping for the system would consist of 288 boreholes with a 20 foot spacing, which was consistent with case studies of similar buildings in similar climates. A Long term financial analysis showed that it would take less than a year to pay off the system, making financial sense as well as making the building greener. (See Appendix for data)

Photovoltaic Systems

The photovoltaic system group was responsible for designing a photovoltaic system which will supplement the energy systems already in place, and lessen the amount of power that will have to be pulled from the grid. The architecture on the south façade was manipulated in order to provide optimal natural light to the interior, while also providing optimal proportions of surface area on which to apply the photovoltaic panels. The Sunmodule 230 was chosen as the panel type to be used after comparison amongst other models and manufacturers. This product provides the highest amount of power generated per panel, which is available on the market. In order to find the power produced from the watt peak (Wp) power a PV solar radiation graph assumed to have a flat plate tilted southwards was referred to and provided by the National Renewable Energy Laboratory, a government organization. Using the average annual Insolation in the Chicago land area from the graph, $4.5 \text{ W/m}^2/\text{day}$, it used to find the approximate percentage of 1000 W/m^2 that was actually hitting the plate under Standard Test Conditions (STC), which came out to be 18.75%. With this number the actual kWh of solar collection in the Chicago land area could be calculated in order to find the amount of energy being produced. With 1125 PV panels rated at 230Wp (Watts-peak) on the south

façade and producing 377.8 kWh of power per panel annually; the panels are capable of creating approximately 425,000 kWh of power annually. The cost is approximately \$892,000 for the panels, not including installation, but there are government incentives available that will reimburse the owner for 30% of overall costs not including the savings on electric bills. (See Appendix for graphs and calculations)

Rainwater Harvesting System

Rainwater harvesting is a technology used to collect, convey and store rain from relatively clean surfaces such as a roof for later use. This is water that would otherwise have gone down the drainage system or into the ground. The water is generally stored in a rainwater tank or directed into mechanisms that can recharge groundwater. Rainwater harvesting can provide water for human consumption, reduce water bills and lessen the need to build reservoirs which may require the use of valuable land. Rainwater harvesting in urban areas and cities can have diverse benefits. Providing supplemental water for the city's requirements, increasing soil moisture levels for urban greenery, increasing the ground water table through artificial recharge, mitigating urban flooding and improving the quality of groundwater are a few of the many benefits. The goal is to reuse the collected rainwater for flushing toilets throughout the building. In order to find how much could be collected the average annual rainfall in the Chicago land area was first to be determined which came out to be 38.01 in/year. The next step was to determine the amount of space available on the site that would be used to collect rainwater. From this information it was determined that the building saves 430,800 gallons of rainwater every year which is saving 11.82% of flushing water by adopting a rainwater harvesting system.

Building Energy Model

For the building energy model two models were analyzed. One was a standard building which met the basic requirements of ASHRAE 90.1-2007 and the other was the new energy efficient design. The energy simulation tool used to analyze the building was eQuest v.3.63. This is a free tool which can be downloaded from the Department of Energy website and proved more than adequate in providing simulation results and comparisons. Compared to other programs tested this was the only one where the actual building footprint could be used rather than assuming a shoebox design like other programs, thus giving the team a more accurate representation of the building's energy consumption. For the standard building, which was compared to the energy efficient model, in order to gain LEED points it must comply with the baseline ASHRAE 90.1-2007 code. Because 90.1 was unavailable to the IPRO group due to time and financial constraints, COMcheck 3.6.1 was downloaded for free from the department of Energy's website. Using COMcheck a basic building envelope was designed which met ASRAE's standards. COMcheck then calculated if the code was met and how much it exceeded the

standards, which was +1%. From this it was determined that the standard building model does indeed meet the required minimum of ASHRAE 90.1-2007 and could be compared to the energy efficient model in order to determine energy saved and meet LEED's criteria for gaining points. Overall the building used a total of 33 percent less energy compared to a standard construction building without the use of alternative energy resources. (Comparison charts can be seen in the Appendix)

LEED Certification

The goal from the beginning was to gain LEED platinum certification for the building since LEED is slowly becoming the industry standard for green efficient design. Throughout the design phase this was kept in mind and reasonable assumptions were made in places where there was not an adequate amount of time to do further research to ensure points. In order to acquire LEED certification the handbook was referenced, which was available online, and a downloadable checklist of current standards was also downloaded for free online. Using results from the energy model as well as power generated through PV and wind energy, points that made up the majority of the points earned were awarded without a doubt and evidence through data to back it up. After reasonable assumptions were made for the remainder of the points the buildings point total came out to 82 points, which meets the requirement of 80+ points for LEED Platinum rating. (See Appendix for checklist)

Conclusions

The IPRO 335 group has spent the good part of the semester putting together a building design that is both architecturally appealing and meets the standards of a green building which can feasibly be LEED Platinum certified. The architectural façade allows for maximum penetration of sunlight as well as an optimum angle for the photovoltaic panels to be mounted on in order to collect the most sunlight. The PV panels selected and mounted will be able to collect enough energy to supplement 10 percent of the buildings energy use. Heat pumps were also selected as a source of energy for the HVAC system which drastically reduces the amount of energy used in a standard system as well as the amount of natural gas that would be consumed for heating otherwise. The wind turbines mounted on the building not only provide a statement of green but also add an additional 1 percent reduction in energy consumption of the building. Using an energy model it was calculated that all the energy saved and produced lead to an overall energy reduction of the building of 42 percent, which will save the owner money in the long run as well as reduce the environmental impact of the building. In order to show that this would be a feasible design it was the intention of the IPRO team not to select all the most expensive materials which would provide the best insulation money could buy. Rather middle of the line materials was selected and an emphasis on alternative sources of energy which can pay themselves off within the lifetime of the building was used in order to provide a feasible model for all future new construction.

Appendix

Team Structure:

1. Groups: Two main sub-groups formed within the team

Architects	Engineers
Eric Dexter Adrian Thovar Leon Jacqueline Schaefer (Head Architect) Justine Banda Kibum Kim Hye Um Jeffrey Burke Robert Christo	Aris Avanesian (Team Leader) Andrew Mey Jonathon Okunaga Ali Razeq (Project Engineer) Joshua Bergerson

2. Research and Design Groups: Pairs of team members formed to do research and complete the design and integration of different building aspects.

Team Members	Topic of Research
Ali Razeq & Eric Dexter	Geothermal Systems
Andrew Mey & Adrian Leon	Wind Turbines
Jacqueline Schaefer & Justine Banda	Solar Heat Collection
Kibum Kim & Hye Um	Reusing Rain and Brown Water
Jon Okunaga & Joshua Bergerson	Structural design
Jeffrey Burke and Robert Christo	Building Model (AutoCAD)
Aris Avanesian	Building Energy Model
Andrew Mey & Ali Razeq	LEED Checklist

3. Major Tasks: Design considerations kept in mind by respective fields

Project Task	Assigned Sub-Group
Site Selection and Layout	Architects
Building Architecture/Designs	Architects
Detail Drawings	Architects
Selection of Type of Structure (steel or concrete)	Both
Green Building concepts	Both
Structural Analysis & Structural Design	Both
Building Comfort (Heating/Cooling)	Engineers
Electrical System	Engineers
Lighting System	Engineers
Acoustics	Engineers
Estimate of Building Cost	Engineers

Architectural Renderings:



Northwest ground view

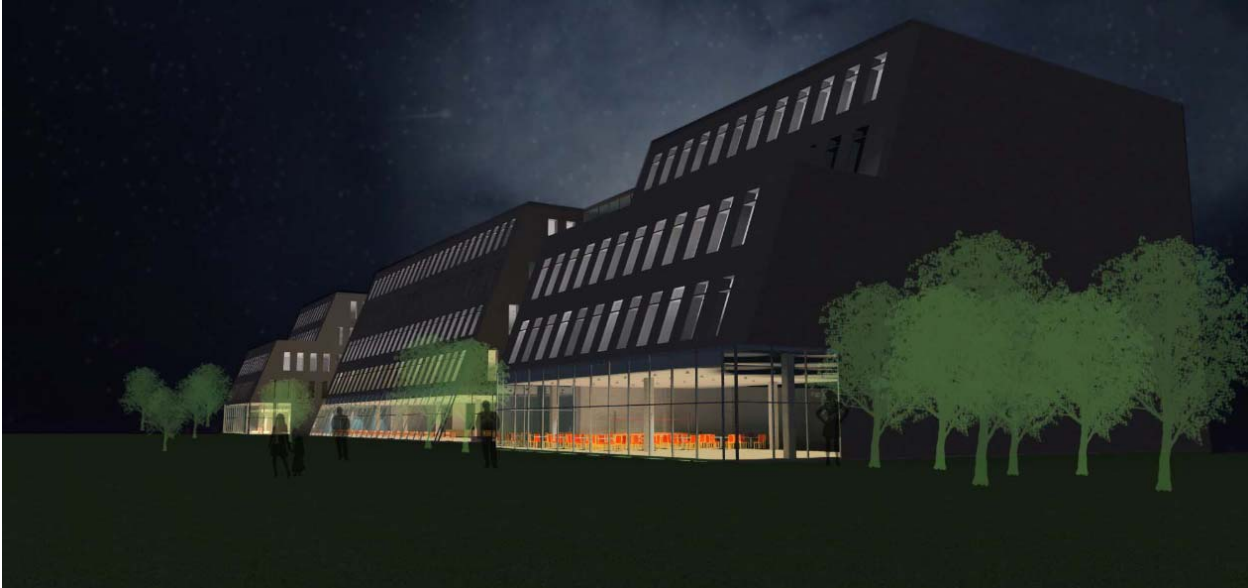

Night Rendering Northwest



Interior Office View



Interior Café View

Structural Data:

Chicago Building Code Considerations

Structural Analysis of Building

Uniform Live Loads:

ROOF	25 PSF
OFFICE	50 PSF
CORRIDORS	100 PSF
LOBBY/ FIRST FLOOR	100 PSF
RETAIL	100 PSF

Partition Loads:

- Partition loading of at least 20psf, unless live load is greater than 80psf
- Partition loading to be treated as a dead uniform loading on columns

Concentrated Loads:

- The following concentrated loads are assumed distributed over an area of 2.5sq ft (unless otherwise noted), located such as to produce the greatest stress in a member or system

Location	Load (lbf)
Elevator machine room grating (area of 4 sq in)	300
Office Floors	2000
Sidewalks	8000
Stair treads (area of 4 sq in on center of tread)	300
Porch, deck and balcony (area of 4 sq in)	300

Roof Loads:

Minimal Loading:

- Roofs shall have a live loading of at least 15 psf

Environmental:

- Environmental loads are not to be reduced by live load reductions
 1. Rain
 - For roof with roof drain heads described in Section 29(13-168-640) shall have loading of 25psf, 3 inch max ponding
 - For roof with roof drains for controlled flow as described in Section 29(13-168-650) shall have loading of 35psf, 6 inch max ponding
 2. Snow
 - Flat roof (slope less than 1 in/ft) to have live load of 25psf.
 - Unbalanced loads??? (half loading)

Lateral Loads:

Height (ft)	Min. wind force resisting system wind pressure (psf)	Components and Cladding wind pressure, other than corner (psf)	Components and Cladding wind pressure, at corner (psf)
200 FT OR LESS	20	25	30

- The pressure specified for components and cladding at corner shall apply over a distance of 10% least building width or .5 height above grade, whichever is smaller.
 - For our building, $.5 * 75 \text{ ft} = 37.5 \text{ ft}$ or $.1 * 120 \text{ ft} = 12 \text{ ft}$; therefore, apply for 12 ft from corners.
- The pressures act in any direction and represent positive or negative pressures.
 1. Flat Roofs
 - Outward pressure of 75% of min. wind force resisting system wind pressure for the roof height and applied over the entire roof area.

Precast SPANCRETE Beam Member Loads and Sizes

A. LOADINGS:

1. Dead Loads:

a. Roof:

8" PRESTRESSED HOLLOWCORE FLOOR SLAB	60 PSF
WATER COLLECTION SYSTEM	3 PSF
2" RIGID INSULATION	2 PSF
MECHANICAL MISC.	4 PSF
Total	69 PSF

b. Typical Interior:

12" PRESTRESSED HOLLOWCORE FLOOR SLAB	90 PSF
SUSPENDED CEILING	2.5 PSF
ELECTRICAL HVAC	5.5 PSF
PLUMBING	2 PSF
INTERIOR COLUMNS	5.5 PSF
MISC.	1.1 PSF
Total	106.6 PSF

c. Typical Exterior:

12" PRESTRESSED HOLLOWCORE FLOOR SLAB	90 PSF
SUSPENDED CEILING	2.5 PSF
ELECTRICAL HVAC	5.5 PSF
PLUMBING	2 PSF
EXTERIOR MOMENT COLUMNS	11 PSF

MISC	1.1 PSF
Total	112.1 PSF

2. Live Loads:

ROOF	25 PSF
OFFICE	50 PSF
CORRIDORS	100 PSF
LOBBY/ FIRST FLOOR	100 PSF

TRIBUTARY WIDTH= 40FT

FOR TYPICAL BEAMS FLOORS 2-5, TOTAL SUPERIMPOSED LOAD= 50 + 112.1= 160 PSF

TOTAL LOADING= 160 PSF* 40 FT = 6400 PLF = 6.4 KLF

FROM SPANCRETE, SELECT INVERTED SPANCRETE T BEAM, 40 x 36

FOR 40' SPAN, MAX LOADING= 8.0 KLF (Tolerance for variation in building programming)

Precast SPANCRETE Floor Panel Loads and Sizes

B. LOADINGS:

3. Dead Loads:

d. Roof:

2" RIGID INSULATION	2 PSF
INVERTED T BEAM	15 PSF
WATER COLLECTION SYSTEM	3 PSF
MECHANICAL MISC.	4 PSF
Total	21 PSF

e. Typical Interior:

INVERTED T BEAM	30 PSF
SUSPENDED CEILING	2.5 PSF
ELCTRICAL HVAC	5.5 PSF
PLUMBING	2 PSF
INTERIOR COLUMNS	5.5 PSF
MISC.	1.1 PSF
Total	46.6 PSF

f. Typical Exterior:

INVERTED T BEAM	30 PSF
SUSPENDED CEILING	2.5 PSF
ELCTRICAL HVAC	5.5 PSF
PLUMBING	2 PSF

EXTERIOR MOMENT COLUMNS	11 PSF
MISC	1.1 PSF
Total	52.1 PSF

4. Live Loads:

ROOF	25 PSF
OFFICE	50 PSF
CORRIDORS	100 PSF
LOBBY/ FIRST FLOOR	100 PSF

For typical slab on floors 2-5, total superimposed load= 52.1+50 = 102.1 PSF

From spancrete site, use 12" standard floor slab, 1.5" strand cover, no structural topping, series: 1.5D 12712

Allowable superimposed load=106psf (based on 100% live load at 40' span, therefore allows for programming variations)

Dead Load Weight of Slab= 86 PSF

For first floor, use slab on grade, poured on site.

LOADINGS: Precast SPANCRETE Column Loads and Sizes

C. LOADINGS:

5. Dead Loads:

g. Roof:

8" PRESTRESSED HOLLOWCORE FLOOR SLAB	60 PSF
INVERTED T BEAM	15 PSF
WATER COLLECTION SYSTEM	3 PSF
2" RIGID INSULATION	2 PSF
MECHANICAL MISC.	4 PSF
Total	84 PSF

h. Typical Interior:

12" PRESTRESSED HOLLOWCORE FLOOR SLAB	90 PSF
INVERTED T BEAM	30 PSF
SUSPENDED CEILING	2.5 PSF
ELCTRICAL HVAC	5.5 PSF
PLUMBING	2 PSF
INTERIOR COLUMNS	5.5 PSF
MISC.	1.1 PSF
Total	136.6 PSF

TRIBUTARY AREA = 1600 FT²

TOTAL LOAD = 1600*136.6

= 218560 LB

= 218.6 Kips

i. Typical Exterior:

12" PRESTRESSED HOLLOWCORE FLOOR SLAB	90 PSF
INVERTED T BEAM	30 PSF
SUSPENDED CEILING	2.5 PSF
ELCTRICAL HVAC	5.5 PSF
PLUMBING	2 PSF
EXTERIOR MOMENT COLUMNS	11 PSF
MISC	1.1 PSF
Total	142.1 PSF

TRIBUTARY AREA = 800 FT²

TOTAL LOAD = 800*142.1

= 113680 LB

= 113.7 Kips

6. Live Loads:

ROOF	25 PSF
OFFICE	50 PSF
CORRIDORS	100 PSF
LOBBY/ FIRST FLOOR	100 PSF

7. Lateral Loadings:

Height (ft)	Min. wind force resisting system Wind pressure (pounds per sq.ft.)
200 FT OR LESS	20

USE 24" x 24" columns for all columns, varying reinforcement.

Cost Estimation of Structural System

This pricing would be for the precast 'erected' in the Chicago area.

Beams - 40 X 36 - \$175 per LF

- From plan, 4900 LF of beams
 - Cost of beams= $\$175 * 4900 = \$857,500$

Columns - 24 X 24 with corbels, multi story - \$175 per LF

- From plan, 3270 LF of columns
 - Cost of columns= $\$175 * 3270 = \$572,250$

12 Inch Spancrete - \$8.00 per SF

- From plan, 244000 SF of floor/roof slab
 - Cost of precast slab= $\$8 * 244000 = \$1,952,000$

Load-bearing insulated wall panels. simple finish, few openings - \$15.00 per SF

- From plan, 53000 SF of load-bearing panels
 - Cost of panels= $\$15 * 53000 = \$795,000$

Non Load-bearing insulated panels-punched openings - \$15.00 per SF

- From plan, 53000 SF of non load-bearing panels
 - Cost of panels= $\$15 * 49600 = \$744,000$

Interior stair and elevator walls - \$13.00 per SF

- From plan, 2500 SF of interior stair and elevator shear walls
 - Cost of interior shear walls= $\$13 * 2500 = \$32,500$

Stairs - Based on the square footage of the stair in plan view - \$50.00 per SF

- From plan, 2750 SF of stairs
 - Cost of Stairs= $\$50 * 2750 = \$137,500$

Total Estimated Cost of Building= \$5,091,000

INVERTED TEE BEAMS



40 X 28 Inverted Tee

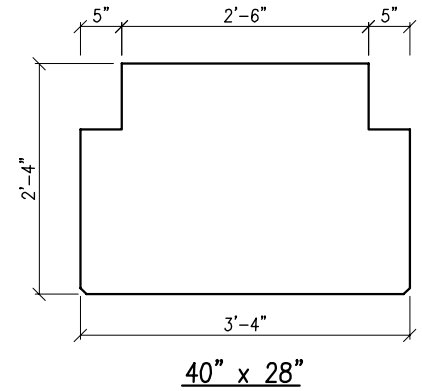
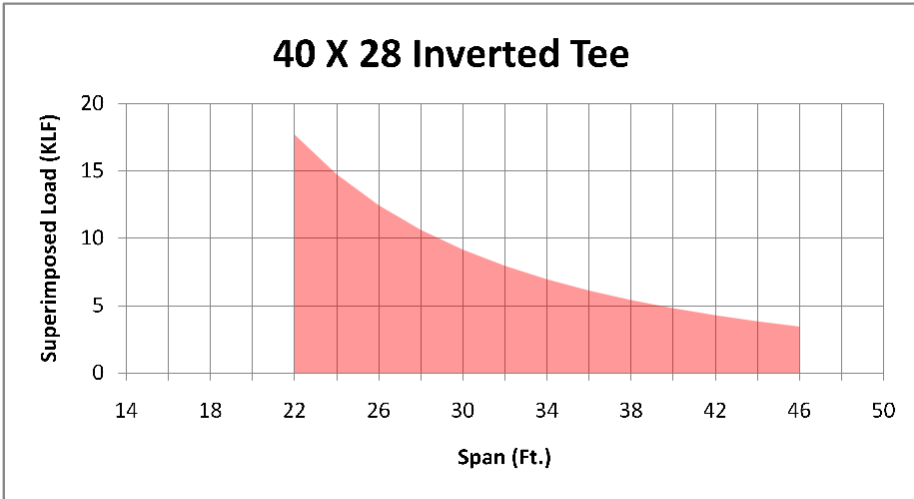

40 X 32 Inverted Tee

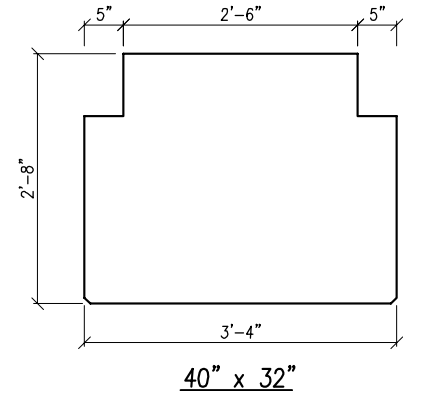
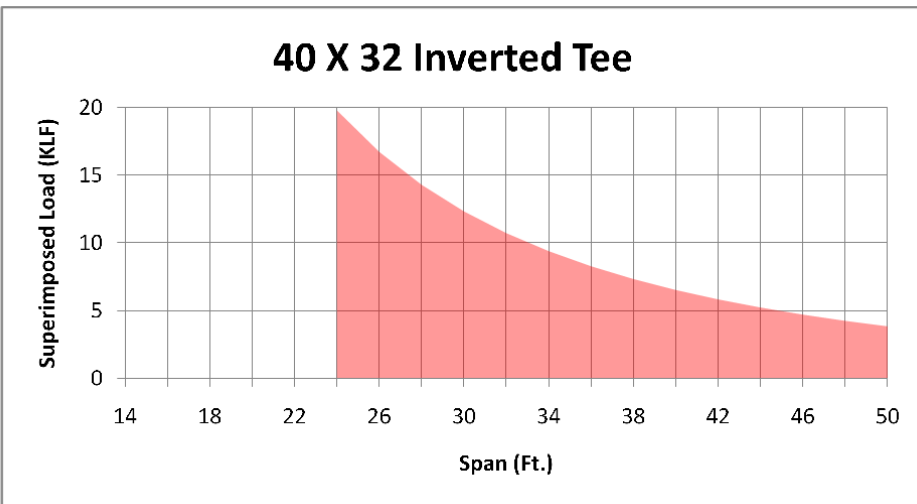

40 X 36 Inverted Tee

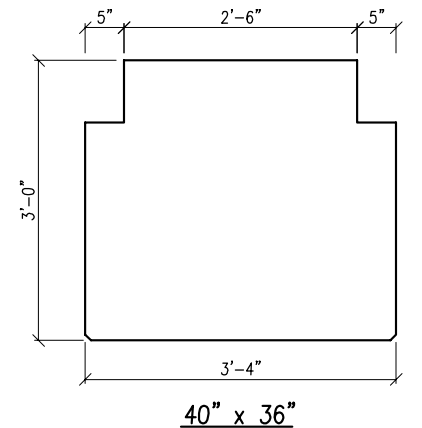
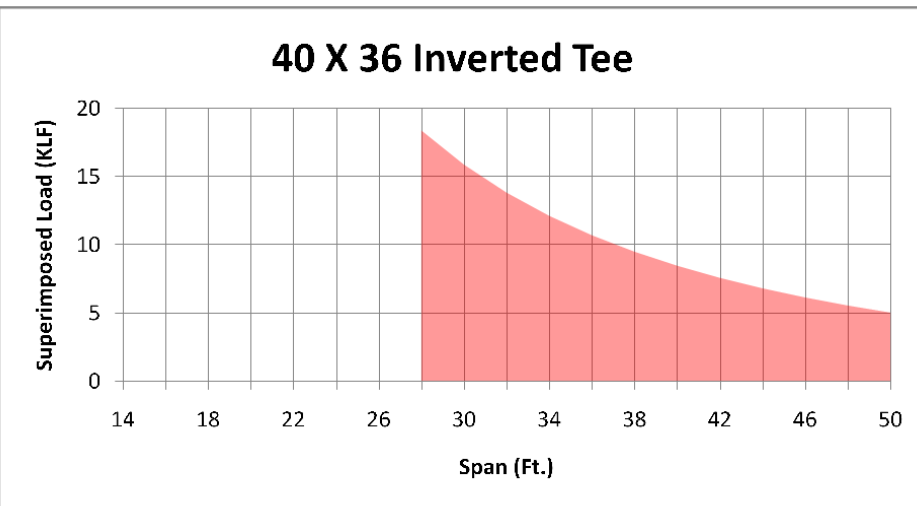

Load Tables are presented as guidelines only. Design requirements must be reviewed by the engineer of record for each specific project.
Spancrete | P.O. Box 828 | Waukesha, WI 53187 | 414-290-9000 | www.spancrete.com

12" STANDARD SPANCRETE 1.50" Strand Cover No Structural Topping

Dead Load Weight of Slab = 86 psf

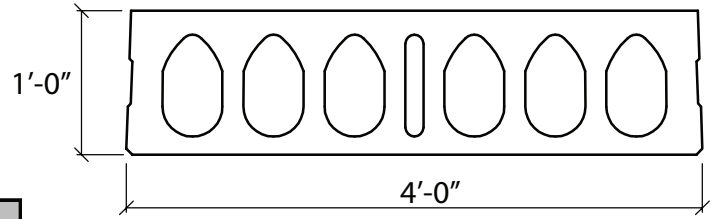

Section Properties		
A=355 in ²	Yt=5.72 in	b=15.6 in
I=5784 in ⁴	Yb=6.28 in	wt=86 psf

ØM _n ft-k/ft	Allowable Superimposed Load in Pounds per Square Foot						
	22.54	30.02	39.49	48.77	57.71	63.32	74.53
Series	1.5D-12606	1.5D-12706	1.5D-12708	1.5D-12710	1.5D-12712	1.5D-12810	1.5D-12812
Span in Feet							
18	283	399					
19	248	351	483				
20	217	311	429				
21	191	276	383	469			
22	168	246	344	429	464	483	
23	149	219	309	396	426	444	458
24	131	196	278	359	397	413	435
25	116	176	251	326	367	382	414
26	102	158	228	296	344	357	392
27	90	141	206	270	321	334	366
28	79	127	187	247	301	313	341
29	70	114	170	225	277	293	321
30	61	102	155	206	254	275	299
31		92	141	189	233	253	282
32		82	128	174	214	233	265
33		73	117	159	197	214	250
34		65	106	146	181	198	231
35			97	135	167	182	213
36			88	124	154	168	197
37			80	114	142	156	183
38			72	104	130	144	170
39				96	120	133	158
40				88	110	123	146
41				81	102	113	136
42				74	93	104	126
43					86	96	117
44					78	89	109
45					72	81	101
46						75	93
47						69	86
48							80
49							74
50							68
51							63

Fire Rating (IBC)

Unrestrained 1 1/2 hours
Restrained 4 hours

Camber

1"-1 1/2"
 ≥ 1 1/2"

Wind Turbine Data:

Letter from wind manufacturer representative:

Hey Andrew!

Here is the quota for the 10kw vertical axis wind turbine;

10kw VAWT 1st Generation

Grid Tie 10KW Complete System- **\$42,670** plus shipping

This price includes:

5.5m (18feet) tower

Power-one wind interface box

UGE power-on grid tie inverter

One year warranty

These are the upgrades available for this wind turbine;

Tower

11m (36feet) add \$4230

Accessories

Extended Warranty (per year up to 5 years) add \$757 per year

*This price may seem higher than other wind turbines from other companies at this size but this price includes every component one would need in-order to start producing energy. Often times other companies list their price just for the wind turbine it-self.

*Check with local authorities to see what kind of incentive program are available in the Illinois.

Although you have inquired about our 10kw wind turbine, we often recommend our customers to go with two 4kw wind turbines because of the following reasons;

- The 4kw wind turbine has just being upgraded with the state of the art technology
- Since the 4kw has been upgraded, it is much more efficient than the 10kw

So here is the quota for the 4kw wind turbine

4KW Vertical Axis Wind Turbine 2nd Generation

Complete System Price- **\$21,920** plus shipping before incentives

This price includes;

Urban Green Energy 4kw Wind Turbine

5.5m (18 feet) tower

Power one wind-Interface box (controller)

Power one grid-tie inverter

One year warranty

If you wish, there are some upgrades available;

Tower

11m (36feet) add \$5010

16.5m (54feet) add \$10,130

Accessories

Lightning protection-add \$295

Extended Warranty (per year up to 5 years)- add \$415/year

Power-On Remote Monitoring -add \$1,475

*This price may seem higher than other wind turbines from other companies at this size but this price includes every component one would need in-order to start producing energy.

Often times other companies list their price just for the wind turbine it-self.

*Check with local authorities to see what kind of incentive program are available in the Illinois.

If you have any more questions regarding our product such as the 4kw, let me know and I'll get back to you immediately. Thank you once again!

Takayuki Koizumi

Hey Andrew,

The roof mount costs US\$4000 for the 4kw. And we can not give you the CAD model for our product. Let me know if there is anything else I can do for you.

Taka

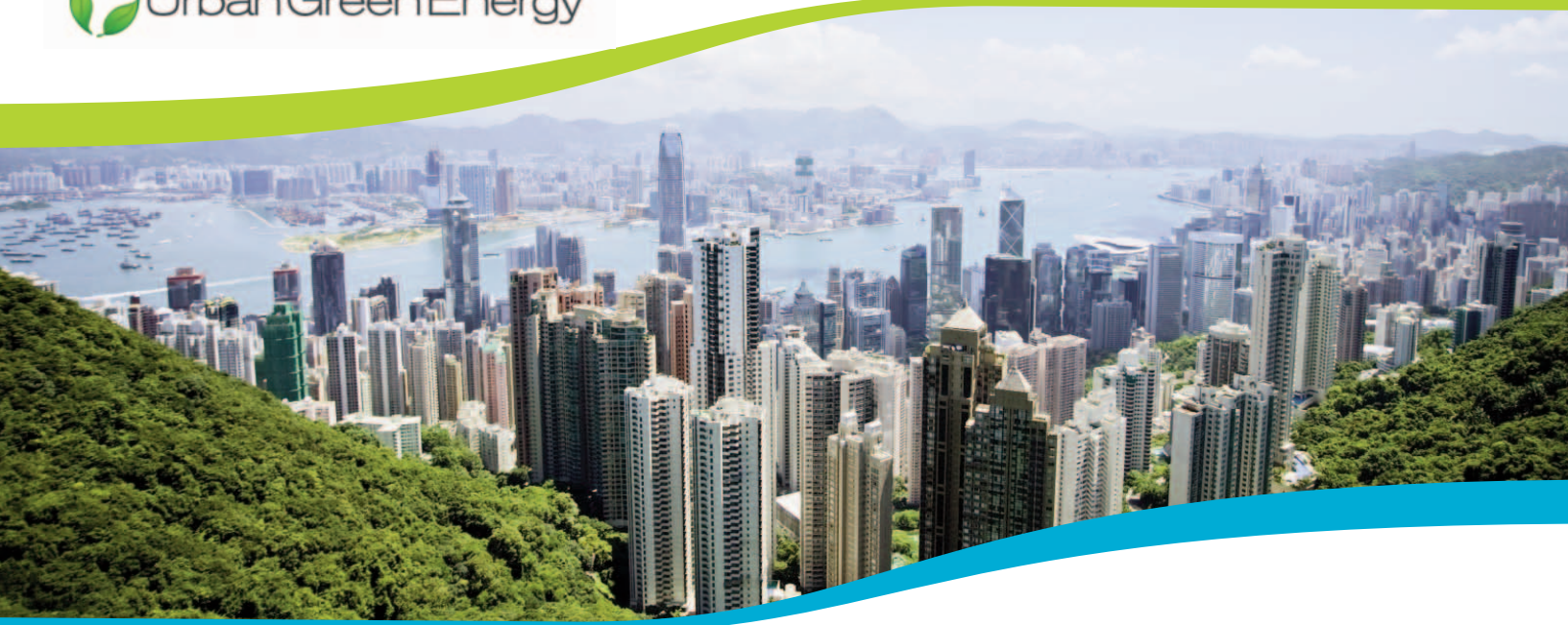

UGE-4K 2nd Generation VAWT Grid-Tie



YOU can make a difference

With Urban Green Energy's UGE-4K, you can make your own energy choice and ensure your energy is provided by 100% clean, renewable energy. Quieter than a human whisper, the UGE-4K can be installed on a tower, on a roof, or just about anywhere!

The UGE-4K was designed to power an average American home when the average wind speed is just over 10 mph (16 km/h).

Grid-tie functionality means that when you generate extra electricity it is sold to your utility company; when your wind turbine isn't producing enough electricity the grid will automatically provide required electricity. Using multiple wind turbines will provide even more power. One of our other models may also help you meet your goals.

Please speak to your local distributor or visit our website for more information on our products and government **incentives** that will make your purchase even more affordable!





Power Output

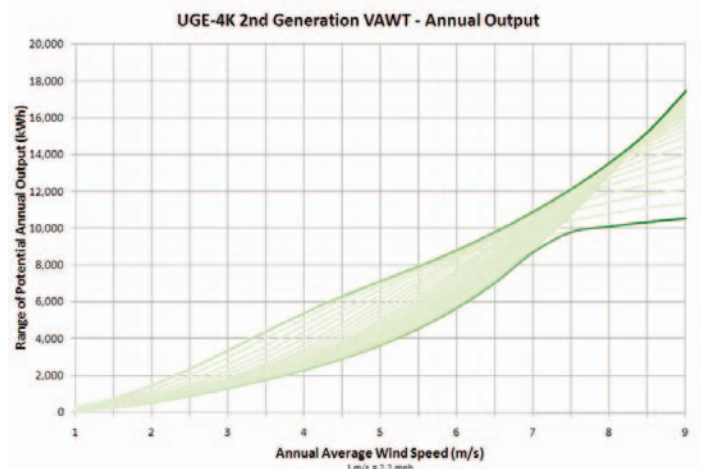
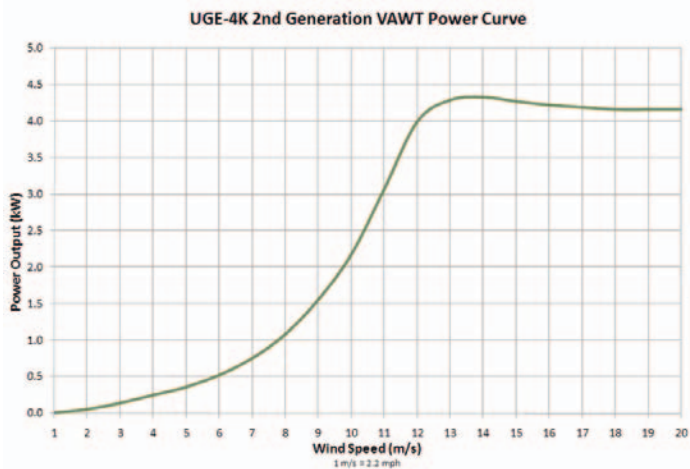

Specifications

Performance:

- Rated Power – 4 kW
- Rated Wind Speed - 12 m/s
- Operating Range - 3 - 25 m/s
- Maximum Wind Speed - 50 m/s
- Noise Level at 3 Meter Distance:
 - @ <7 m/s - < 27 DB
 - @ 7 - 10 m/s - < 32 DB
 - @ 10 - 13 m/s - < 37 DB

Generator:

- Type - Permanent magnet direct drive generator
- Temperature range - -40°C to 115°C

Wind Interface Box: (Power-One Aurora PVI-7200)

Output: 0-600Vdc

Grid-tie Inverter: (Power-One Aurora PVI-4200)

Input: 50 - 580Vdc

Grid-tie inverter is ordered to meet local grid specifications. Battery back-up is available as an option.

Physical Parameters:

- Mill Size - 4.2m x 2.75m (165" x 108")
- Tower Height (Standard) - 5.5m (18')
- Gross Weight w/o Tower - 200kg (440lbs)
- Gross Weight w/ Tower - 500kg (1120lbs)
- Gross Weight w. Roof mount - 350kg (770 lbs)

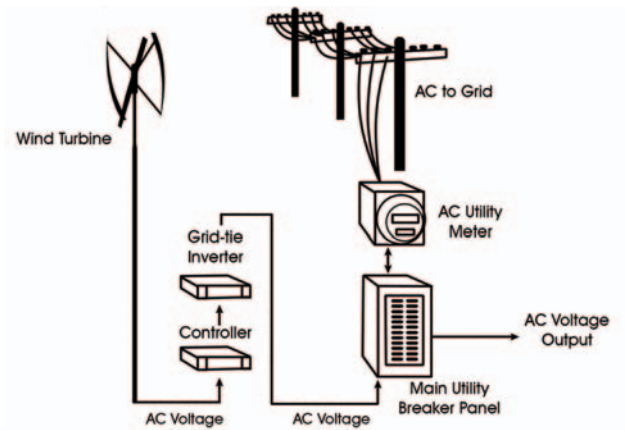

Wind Turbine System Cash Flow

Assumptions (Inputs)

Total Installed Cost (\$):	\$285,120
Allocation to Business (%):	0
Annual Energy Output (kWh):	44,000
Electricity Cost (\$/kWh):	\$0.1380
Electricity Inflation Rate (%):	2
O & M Cost (\$/kWh):	\$0.005
O & M Inflation Rate (%):	3
State Rebate (%):	0
State Tax Credit (%):	25
Federal Tax Credit (%):	30

Results

Ave. Monthly Savings on Bill

Year 1 (\$):	\$506
Year 10 (\$):	\$617
Year 20 (\$):	\$752
Year 30 (\$):	\$917

Internal Rate of Return

Years 1 - 30:	3.0%
---------------	-------------

Annual Cash Flow Model

Year	Net Energy	O&M Costs	Annual Cash Flow	Total Cash Flow
0			(\$149,688)	(\$149,688)
1	\$6,072	\$0	\$6,072	(\$143,616)
2	\$6,193	\$0	\$6,193	(\$137,423)
3	\$6,317	\$0	\$6,317	(\$131,105)
4	\$6,444	\$0	\$6,444	(\$124,662)
5	\$6,573	\$0	\$6,573	(\$118,089)
6	\$6,704	(\$255)	\$6,449	(\$111,640)
7	\$6,838	(\$263)	\$6,575	(\$105,065)
8	\$6,975	(\$271)	\$6,704	(\$98,361)
9	\$7,114	(\$279)	\$6,836	(\$91,525)
10	\$7,257	(\$287)	\$6,970	(\$84,555)
11	\$7,402	(\$296)	\$7,106	(\$77,449)
12	\$7,550	(\$305)	\$7,245	(\$70,204)
13	\$7,701	(\$314)	\$7,387	(\$62,817)
14	\$7,855	(\$323)	\$7,532	(\$55,285)
15	\$8,012	(\$333)	\$7,679	(\$47,606)
16	\$8,172	(\$343)	\$7,829	(\$39,777)
17	\$8,336	(\$353)	\$7,983	(\$31,794)
18	\$8,502	(\$364)	\$8,139	(\$23,656)
19	\$8,672	(\$375)	\$8,298	(\$15,358)
20	\$8,846	(\$386)	\$8,460	(\$6,898)
21	\$9,023	(\$397)	\$8,625	\$1,727
22	\$9,203	(\$409)	\$8,794	\$10,521
23	\$9,387	(\$422)	\$8,966	\$19,487
24	\$9,575	(\$434)	\$9,141	\$28,628
25	\$9,766	(\$447)	\$9,319	\$37,947
26	\$9,962	(\$461)	\$9,501	\$47,448
27	\$10,161	(\$474)	\$9,687	\$57,135
28	\$10,364	(\$489)	\$9,876	\$67,010
29	\$10,571	(\$503)	\$10,068	\$77,078
30	\$10,783	(\$518)	\$10,264	\$87,343

Conservative assumption of no scrap value after 30 years.

Cash flow analysis is pre-tax.

Ground Loop Design

Borehole Design Project Report - 11/23/2009

Project Name: Green Building Design - Geothermal		Project Start Date: 10/30/2009
Designer Name: Ali Razeq & Eric Dexter		
Date: 11/20/2009		
Client Name: Illinois Institute of Technology		
Address Line 1: 3300 South State Street		
Address Line 2:		
City: Chicago	Phone: 312-567-3000	
State: IL	Fax:	
Zip: 60616	Email: arazeq@iit.edu	

Calculation Results

	COOLING	HEATING
Total Length (ft):	83391.2	0.0
Borehole Number:	288	288
Borehole Length (ft):	289.6	0.0
Ground Temperature Change (°F):	+6.3	0.0
Unit Inlet (°F):	85.0	50.0
Unit Outlet (°F):	94.9	44.0
Total Unit Capacity (kBtu/Hr):		
Peak Load (kBtu/Hr):	5173.4	1887.2
Peak Demand (kw):	361.5	139.4
Heat Pump EER/COP:	14.3	4.0
System EER/COP:	14.3	4.0
System Flow Rate (gpm):	1293.3	471.8

Input Parameters

Fluid	Soil
Flow Rate: 3.0 gpm/ton	Ground Temperature: 51.1 °F
Fluid: 15% Ethylene Glycol	Thermal Conductivity: 1.30 Btu/(h*ft*°F)
Specific Heat (Cp): 1.00 Btu/(°F*lbm)	Thermal Diffusivity: 0.75 ft ² /day
Density (rho): 62.4 lb/ft ³	

Piping

Pipe Type:	1 1/4 in. (32 mm) - SDR11
Flow Type:	Turbulent
Pipe Resistance:	0.104 h*ft*°F/Btu
U-Tube Configuration:	Single
Radial Pipe Placement:	Along Outer Wall
Borehole Diameter:	5.00 in
Grout Thermal Conductivity:	0.85 Btu/(h*ft*°F)
Borehole Thermal Resistance:	0.185 h*ft*°F/Btu

Input Parameters

Pattern	Modeling Time Period
Vertical Grid Arrangement: 18 x 16	Prediction Time: 15.0 years
Borehole Number: 288	Long Term Soil Temperatures:
Borehole Separation: 20.0 ft	Cooling: 57.4 °F
Boreholes per Parallel Circuit: 1	Heating: 51.1 °F
Fixed Length Mode: Off	
Grid File: None	
File:	
Heat Pumps	Optional Boiler/Cooling Tower
Manufacturer: Florida Heat Pump	Tower
Series: ES Series R-410A	Boiler
Design Heat Pump Inlet Load Temperatures:	0 %
Cooling (WB)	0.0
Heating (DB)	0.0
Water to Air: 67.0 °F	Cooling Tower Flow Rate (gpm): 0.0
Water to Water: 55.0 °F	Cooling Range (°F): 10.0
	Annual Operating Hours (hr/yr): 0
Extra kw	Loads File
Pump Power: 0.0 kw	
Cooling Tower Pump: 0.0 kw	
Cooling Tower Fan: 0.0 kw	
Additional Power: 0.0 kw	

Ground Loop Design
Zone Report - 11/23/2009

Project Name: Green Buliding Desing - Geothermal
 Designer Name: Ali Razeq & Eric Dexter
 Date: 11/20/2009
 Client Name: Illinois Institute of Technology
 Address Line 1: 3300 South State Street
 Address Line 2:
 City: Chicago
 State: IL
 Zip: 60616

Project Start Date: 10/30/2009

Phone: 312-567-3000
 Fax:
 Email: arazeq@iit.edu

Zone 1	Unit Inlet (°F): IPRO 335	COOLING 85.0	HEATING 50.0
Loads	Design Day Loads		
	Time of Day	Heat Gains (kBtu/Hr)	Heat Losses (kBtu/Hr)
	8 a.m. - Noon	541.8	1887.2
	Noon - 4 p.m.	5173.4	310.7
	4 p.m. - 8 p.m.	541.8	310.7
	8 p.m. - 8 a.m.	541.8	310.7
			Annual Equivalent Full-Load Hours Cooling: 1100 Heating: 697
			Days Occupied per week: 5.0

Heat Pumps

Pump Name: ES070
 Number of Units: 76
 Manufacturer: Florida Heat Pump
 Series: ES Series R-410A
 Pump Type: water to Air

Capacity (kBtu/Hr)	Cooling	Heating
Power (kw)	5221.2	5029.4
EER/COP	364.80	371.57
Flow Rate (gpm)	14.3	4.0
Partial Load Factor	1293.3	471.8
Load Temp. (°F)	0.99	0.38
Load Flows (CFM)	67.0	70.0
(gpm)	2200	2200

ENVIROSAVER

heat pumps

Our single state **ES EnviroSaver Series** is designed to provide your customer a highly efficient unit at a cost effective price. Our greatest challenge today is the preservation of our environment. Depletion of the ozone and global warming are both addressed by FHP's **EnviroSaver Series**. Refrigerant R-410A, the industry's alternative to ozone depleting refrigerant R-22 meets EPA standards. High efficiency not only saves your customer money on their energy bills but helps reduce carbon dioxide emissions, a leading cause of global warming.

FHP's **EnviroSaver Series** is designed with ECM (Electronically Commuted Motor) fan motors as standard. This motor will provide additional energy savings and a greater level of comfort in the living space. When dirt builds up on the filter reducing air flow the ECM motor automatically adjusts to maintain full air flow ensuring peak performance of the unit and no loss of comfort. All FHP's **ES EnviroSaver** units are ARI/ISO 13256-1 performance certified for Water Loop, Ground Loop and Ground Water applications making them suitable for virtually any application. ES units are available in Vertical, Horizontal and Counter Flow models as well as multiple return and supply air configurations making it easy to find a unit to meet your requirements.

All FHP Series units come ready for operation in a geothermal application. Geothermal installations are the most cost-effective and energy efficient heating and cooling systems available today.

Increase your energy savings with an internally mounted heat recovery system providing much of your hot water needs at virtually no additional operating cost.

● Cost Effective

Up to 60% savings are possible using FHP's **ES EnviroSaver Series** in a geothermal application. Additional investment costs are more than offset when energy cost savings are considered. The system's long life and low maintenance help reduce the overall life cycle costs.

● Environmentally Friendly

FHP is the industry leader in the development of the environmentally friendly technology that is designed into the **EnviroSaver Series**. Using Refrigerant R-410A gives you protection from potentially skyrocketing maintenance costs associated with obsolete refrigerants.

● FHP Quality and Reliability

FHP's **EnviroSaver Series** feature coated evaporator coils and stainless steel drain pans as standard to ensure long trouble free life of the units. Rigorous factory testing of each unit ensures trouble free operation from the start while FHP's thirty years of experience in heat pumps are your assurance of a state of the art quality product.



ES SERIES

VERTICAL

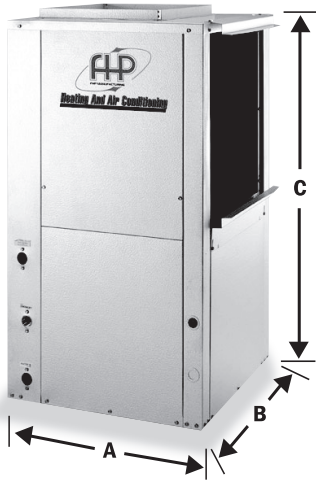

HORIZONTAL

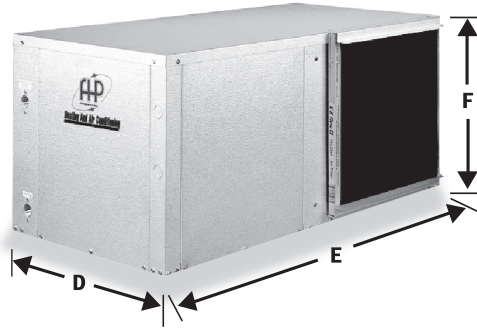

COUNTERFLOW

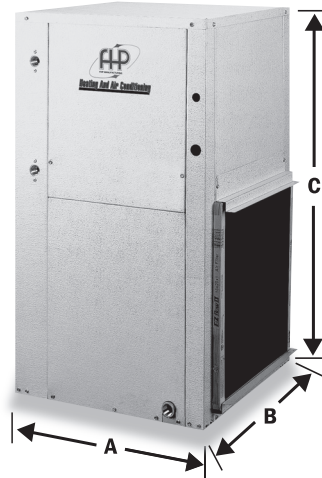

DIMENSIONS						
MODEL	VERTICAL/C. FLOW			HORIZONTAL		
	WIDTH	DEPTH	HEIGHT	WIDTH	LENGTH	HEIGHT
	A	B	C	D	E	F
ES018	21.50	21.50	40.25	25.50	43.00	21.75
ES024	21.50	21.50	40.25	25.50	43.00	21.75
ES030	21.50	26.00	47.25	26.00	54.50	21.75
ES036	21.50	26.00	47.25	26.00	54.50	21.75
ES042	24.00	32.75	47.25	30.00	68.00	21.75
ES048	24.00	32.75	47.25	30.00	68.00	21.75
ES060	26.00	33.25	51.25	30.00	68.00	21.75
ES070	26.00	33.25	58.25	30.00	78.00	21.75

All ratings & specifications are subject to change without notice.

MODEL		ARI / ISO 13256-1 PERFORMANCE DATA											
		ENTERING WATER TEMPERATURES											
		Water Loop		Ground Loop				Ground Water					
		86°F	68°F	77°F	32°F	59°F	50°F						
CFM		CAPACITY AND EFFICIENCY DATA											
		COOLING CAPACITY (WLHP)	EER (WLHP)	HEATING CAPACITY (WLHP)	COP (WLHP)	COOLING CAPACITY (GLHP)	EER (GLHP)	HEATING CAPACITY (GLHP)	COP (GLHP)	COOLING CAPACITY (GWHP)	EER (GWHP)	HEATING CAPACITY (GWHP)	COP (GWHP)
ES018	650	18,500	15.2	24,000	5.6	19,500	19.6	14,500	3.5	22,000	27.4	19,000	4.4
ES024	800	25,000	14.2	32,500	4.3	27,000	15.9	20,500	3.4	29,500	21.9	26,500	3.7
ES030	1000	30,000	16.0	33,500	4.8	31,000	19.0	22,000	3.5	34,500	25.0	27,500	4.2
ES036	1200	33,000	15.6	39,000	5.2	34,000	19.0	24,000	3.5	38,500	23.9	31,500	4.4
ES042	1400	43,000	14.3	47,000	4.7	44,500	16.5	30,500	3.3	47,000	21.6	39,000	4.1
ES048	1600	48,500	14.3	58,000	4.9	49,000	17.2	37,500	3.5	55,000	21.6	47,000	4.3
ES060	2000	57,500	13.6	66,000	4.4	60,000	15.6	45,000	3.3	68,000	20.1	56,000	3.9
ES070	2200	68,000	14.0	80,000	4.6	70,000	15.6	53,000	3.3	76,000	20.3	68,000	4.1

Tabulated performance data is at noted entering water temperatures and entering air conditions of 80.6° F DB/66.2° F WB at ARI/ISO 13256-1 rated CFM

ENERGY STAR RATED



PERFORMANCE DATA

FHP MANUFACTURING COMPANY

601 N.W. 65TH COURT • FT. LAUDERDALE, FL 33309 • PHONE: (954) 776-5471 • FAX: (800) 776-5529

CANYON VIEW HIGH SCHOOL CEDAR CITY, UTAH

Andrew Chiasson
Geo-Heat Center



LOCATION & BACKGROUND

The Canyon View High School is located in Cedar City, UT, about 90 miles (145 km) northeast of the point of intersection of Utah, Arizona, and Nevada. It is a two-story building with 233,199 ft² (21,665 m²) of floor space, and construction was completed in 2001.

Average high temperatures in the region in July are about 93°F (33.9°C) and average low temperatures in January are about 15°F (-9.4°C). There are approximately 6100 (3390°C-day) heating degree days and 700 (390°C-day) cooling degree days per year [65 °F (18°C) base].

The Canyon View ground-source heat pump system is considered the first “large” geexchange system in the Central Rocky Mountain Region.

SYSTEM DESCRIPTION

Ground Source System

The ground source system (Figure 1) is the vertical closed loop type consisting of 300 vertical boreholes, each 300 ft (91.4 m) deep, for a total length of 90,000 ft (27,432 m). The boreholes, installed under the school playing field, are placed in a 15 x 20 grid pattern with a 20-ft (6.1-m) borehole spacing and 25-ft (7.6-m) spacing between run-outs. A single u-tube heat exchanger is installed in each borehole, and the borehole field is piped in a reverse-return arrangement.

The mean annual ground temperature in this location is approximately 53°F (11.7°C). An in-situ thermal

conductivity test revealed that the average thermal conductivity of the soil to a depth of 300 ft (91.4 m) is 1.19 Btu/hr-ft-°F (2.06 W/m-°C). The loop field was installed in basin-fill type sediments, consisting of coarse sand and gravel with clay stringers and trace volcanics.

Interior System

The total installed heat pump capacity at the Canyon View High School is approximately 550 tons (1953 kW). Space conditioning is accomplished by over 100 water-air heat pumps, which are installed in ceiling spaces to serve individual classrooms and other zones. Outdoor air is introduced through heat recovery ventilator (HRV) units. The original design called for total energy recovery (ERV) units, but HRV's were installed due their to lower cost. There is little use of domestic hot water in the school, and thus it is generated partially by water-water heat pumps and natural-gas water heaters. The fluid distribution system consists of a central pumping system with a variable frequency drive.

A generalized schematic of the system is shown in Figure 2. Figure 3 is a photograph of the ground-loop headers in the mechanical room and Figure 4 is a photograph of a typical horizontal, ceiling-mounted water-air heat pump.

PROJECT COSTS

The Canyon View High School is an example of a building where a ground-source heat pump system was

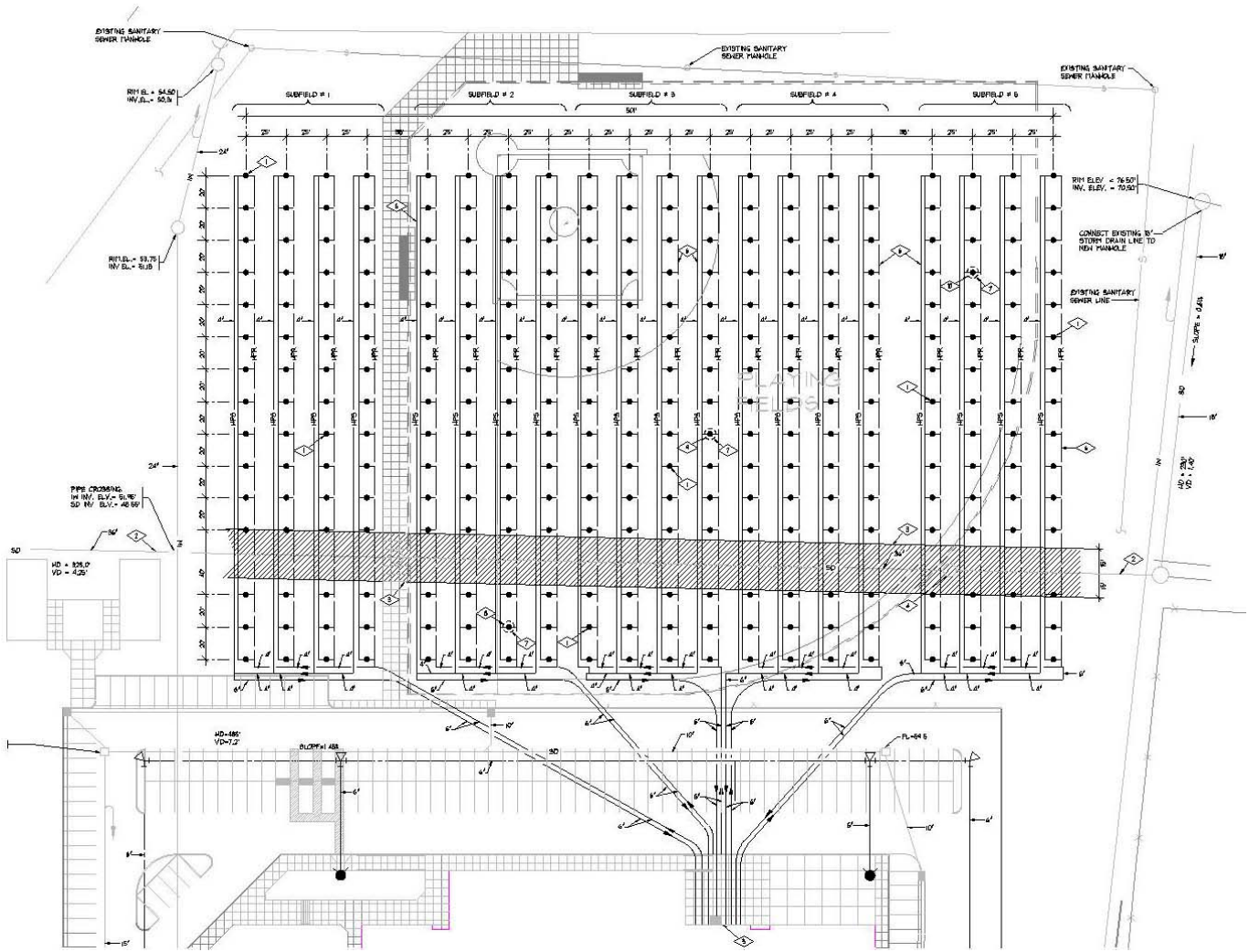

Figure 1. Canyon View High School ground loop field.

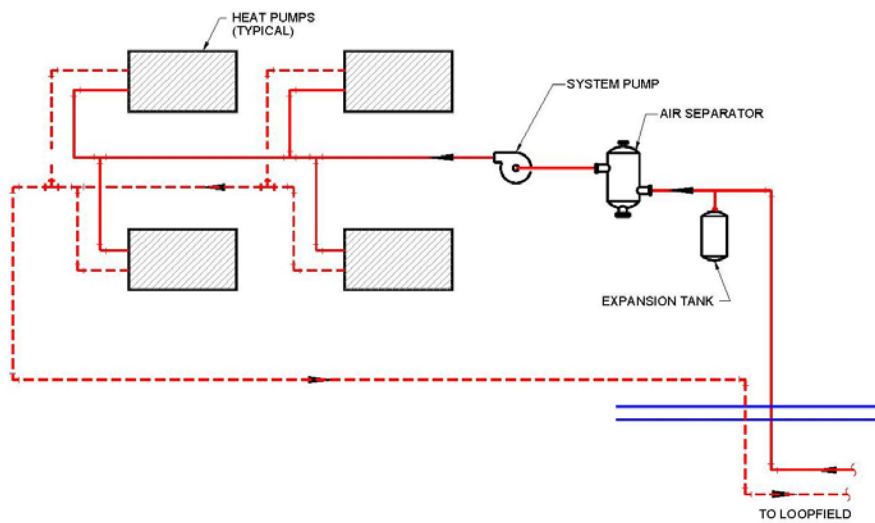

Figure 2. Schematic of the ground-source heat pump system at the Canyon View High School.

cheaper to install than a conventional boiler chiller system. The project costs are summarized as follows:

- Conventional Mechanical System Bid:
\$17.00/ft² (\$183.00/m²)
- Canyon View High School Ground Source System Bid:
 - Mechanical/Plumbing bid: \$2,457,000
 - Loop Field bid: \$778,000
 - Total Ground Source bid: \$3,235,000
 - Mechanical Cost/ft² (m²): **\$13.87/ft² (\$149.30/m²)**
 - Cost Savings: \$3.13/ ft² (\$33.69/m²) = **\$729,000**

Additional cost savings may be realized if one considers architectural savings in the mechanical room floor space in the ground-source system over the conventional system. For the Canyon View High School, the mechanical room for the ground-source system is 2,680 ft² (249 m²), or 1.15% of the total floor space. Comparing this value to 3.80% of mechanical room floor space to total floor space for average schools, and assuming \$50/ft² (\$538/m²) cost of new construction, an additional savings of \$309,000 may be realized.



Figure 3. Photograph of the mechanical room at the Canyon View High School, showing the ground loop field supply and return headers.

SYSTEM PERFORMANCE AND OPERATING COST

The system has performed as designed. Maximum ground loop temperatures observed in the summer are about 92°F (33.3°C) and minimum loop temperatures in the winter are 40-42°F (4.4-5.5°C). Annual utility costs for 2001-2002 are summarized as follows:

- Annual Utility Costs for Canyon View High School:
 - Electricity: \$135,886.54 (96%)
 - Natural Gas: \$5,446.87 (4%)
 - Total: \$141,333.41
 - Cost/ft² (m²): \$0.61/ft² (\$6.57/m²)

- Utility Costs for a Comparable School:
 - Cost/ft² (m²): \$0.86/ft² (\$9.26/m²)
(77% electrical, 23% gas)
- Operating Cost Savings: \$0.25/ ft² (\$2.69/m²)
= **\$58,300 (or 29%)/year**



Figure 4. Photograph of a typical horizontal, ceiling-mounted water-air heat pump.

OPERATING EXPERIENCES

Although the geexchange system at the Canyon View High School is performing well, it is a large system, and the designer admits that there are ways that the pumping system could have been designed to optimize energy consumption. For example, systems of similar size are being designed with primary/secondary pumping, multiple loop pumps to utilize only as much of the ground loop as necessary, and distributed pumping in the building.

Most heat pumps are installed in ceiling spaces, and access has been a bit tight. Dirt and sand was a problem in the system for about 6 months after start-up, which was attributed to a damaged header pipe, likely caused by landscaping work.

ACKNOWLEDGEMENTS

The Geo-Heat Center wishes to thank Cary Smith of Sound Geothermal for providing the data and information for this case study

OVERALL SUMMARY

Building Description:

- Location:* Cedar City, Utah
- Occupancy:* School
- Gross Floor Area:* 233,199 ft² (21,665 m²)
- Number of Floors:* 2
- Type of Construction:* New
- Completion Date:* 2001
- July Avg. High Temp.:* 93°F (33.9°C)
- Jan Avg. Low Temp.:* 15°F (-9.9°C)
- Annual Heating Degree Days:* 6100°F-day (3390°C-day)

Annual Cooling Degree Days: 700°F-day (390°C-day)

Interior System:

Total Installed Heat Pump Capacity: ~550 tons (1,935 kW)

No. of Heat Pump Units: 100+

Pumping System: Central with VFD

Ground-Source System:

Geologic Materials: Basin-fill sediments

Mean Ann. Ground Temp.: 53°F (11.7°C)

Type: Vertical closed loop, single U-tube

Configuration: 300 boreholes (15x20 grid pattern)

300 ft (91.4 m) deep,

20 to 25 ft (6.1 to 7.6 m) spacing

Borehole per ton: ~164 ft/ton (14.2 m/kW)

Economic Analysis:

Installed Geothermal HVAC Capital Cost:

\$3,235,000 (\$13.87/ft²)(\$149.30/m²)

Conventional HVAC Capital Cost Bid:

\$3,963,363 (\$17.00/ft²)(\$183.00/m²)

Annual HVAC Energy Cost (2001-2002):

\$141,333 (\$0.61/ft²)(\$6.57/m²)

Annual HVAC Energy Cost of Comparable Conventional School:

\$200,500 (\$0.86/ft²) (\$9.26/m²)

Annual HVAC Energy Savings:

29%

Estimated Simple Payback Period:

Immediate

Photovoltaic Data:

20,265 SF of Solar panel area on the south facade

230 Wp per panel of power

Each panel is 18 SF

$20,265 / 18 = 1125$ panels

4.5 kWh/m²/day from PV solar radiation graph

Insolation Percent: 18.75%

kWh/panel = $(230W \times .1875 \times 87600h) / 1000 = 377.8$ kWh/panel

1125 panels x 377.8 kWh/panel = 424,996.8 kWh produced per year

\$793 per panel

\$892,125 total

Converting kWh/m ² /day to kWh:		kWh/m ² /day * 1day/24h = kWh/m ²			
kWh/m ² /day	W/m ²	Rated Insolation	Insolation %	Power Produced (kWh/panel)	Total Power Produced Annually (kWh)
4.5	187.5	1000	18.75%	377.775	424996.875
5	208.333	1000	20.83%	419.75	472218.75
					Insolation Percentage is based on 1000W/m ² PV Standard Test Conditions.

Spreadsheet Calcs

Annual

PV Solar Radiation (Flat Plate, Facing South, Latitude Tilt)

Model estimates of monthly average daily total radiation using inputs derived from satellite and/or surface observations of cloud cover, aerosol optical depth, precipitable water vapor, albedo, atmospheric pressure and ozone resampled to a 40km resolution. See http://www.nrel.gov/gis/ll_solar_pv.html documentation for more details.

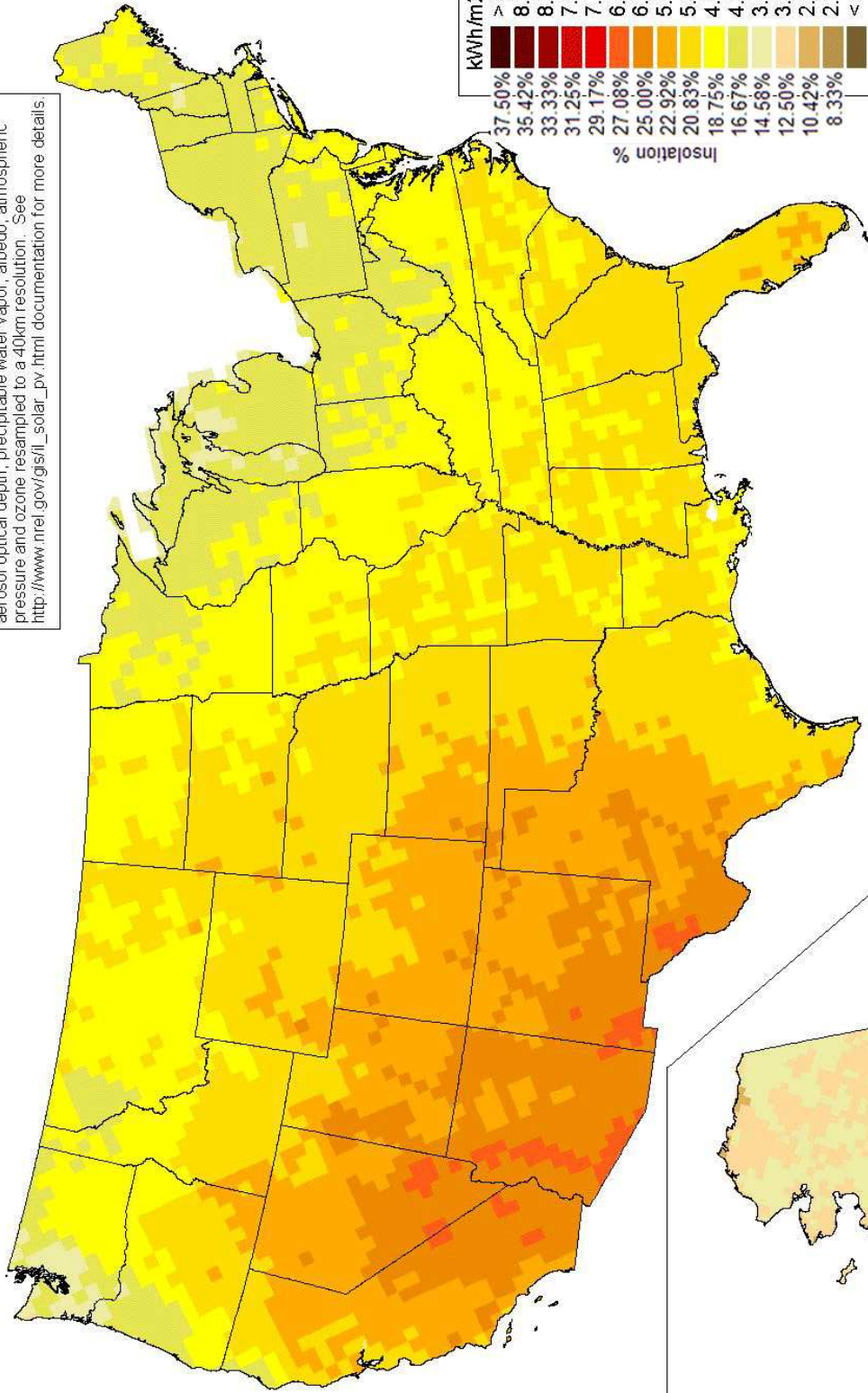

Insolation Percentage is based on 1000W/m2 PV Standard.



Produced by the Electric & Hydrogen Technologies & Systems Center - May 2004



Sunmodule[®] SW 220/230 mono



The Sunmodule from SolarWorld represents one of the best values in the PV industry. The Sunmodule's tight power tolerance of +/-3% ensures the highest system efficiency without the need for on-site module sorting. The fully automated manufacturing process at SolarWorld's ISO 9001-2000 factories produces modules with consistently high quality. Choosing the Sunmodule[®] will ensure high kWh yields for the long term.

To guarantee long term yields, Sunmodules are built to last. SolarWorld bonds the tempered glass laminate deep into the aluminum frame with a continuous bead of silicone adhesive. This method guarantees exceptional rigidity for the entire module and prevents the frame from loosening or pulling away from the glass in cases such as the sliding of heavy snow or handling. Tests carried out in accordance with IEC 61215, which applies loads of up to 113 lb/sf (5.4 kN/m²) demonstrate that the module can withstand high loads such as heavy accumulations of snow and ice.

The Sunmodule[®] features a patented, low profile junction box with integrated 25A Schottkey bypass diodes that is completely sealed against corrosion. The ability to rapidly dissipate excess heat allows the diodes and junction box to operate at lower temperatures. The junction box is reliably connected by a solid, welded bond to guarantee lasting functionality and is factory-equipped with high-quality, robust cables and locking connectors. All Sunmodules carry a 25-year performance warranty and can be returned to SolarWorld at their end of life for recycling



SolarWorld. And EveryDay is a SunDay.

www.solarworld-usa.com

Sunmodule[®]

SW 220/230 mono

Performance under standard test conditions

		SW 220	SW 230
Maximum power	P_{max}	220 Wp	230 Wp
Open circuit voltage	V_{oc}	36.6 V	36.9 V
Maximum power point voltage	V_{mpp}	29.3 V	29.6 V
Short circuit current	I_{sc}	8.18 A	8.42 A
Maximum power point current	I_{mpp}	7.51 A	7.76 A

Performance at 800 W/m², NOCT, AM 1.5

		SW 220	SW 230
Maximum power	P_{max}	157 Wp	164 Wp
Open circuit voltage	V_{oc}	33.1 V	33.4 V
Maximum power point voltage	V_{mpp}	26.3 V	26.6 V
Short circuit current	I_{sc}	6.76 A	6.96 A
Maximum power point current	I_{mpp}	5.98 A	6.18 A

Minor reduction in efficiency under partial load conditions at 25°C: at 220 W/m², 95% (+/- 3%) of the STC efficiency (1000 W/m²) is achieved.

Component materials

Cells per module	60
Cell type	monocrystalline silicon
Cell dimensions	6.14 x 6.14 in ² (156 x 156 mm ²)

System integration parameters

Maximum system voltage SC II	1,000 V _{DC}
Maximum system voltage USA NEC	600 V _{DC}
Maximum series fuse rating	15 A
Maximum reverse current	Do not apply external voltages larger than V _{oc} to the module

Thermal characteristics

NOCT	46°C
TC I _{sc}	0.042 %/K
TC V _{oc}	-0.33 %/K
TC P _{max}	-0.45 %/K

Additional data

Power tolerance	+/- 3 %
Junction box	IP 65
Connector	MC type 4

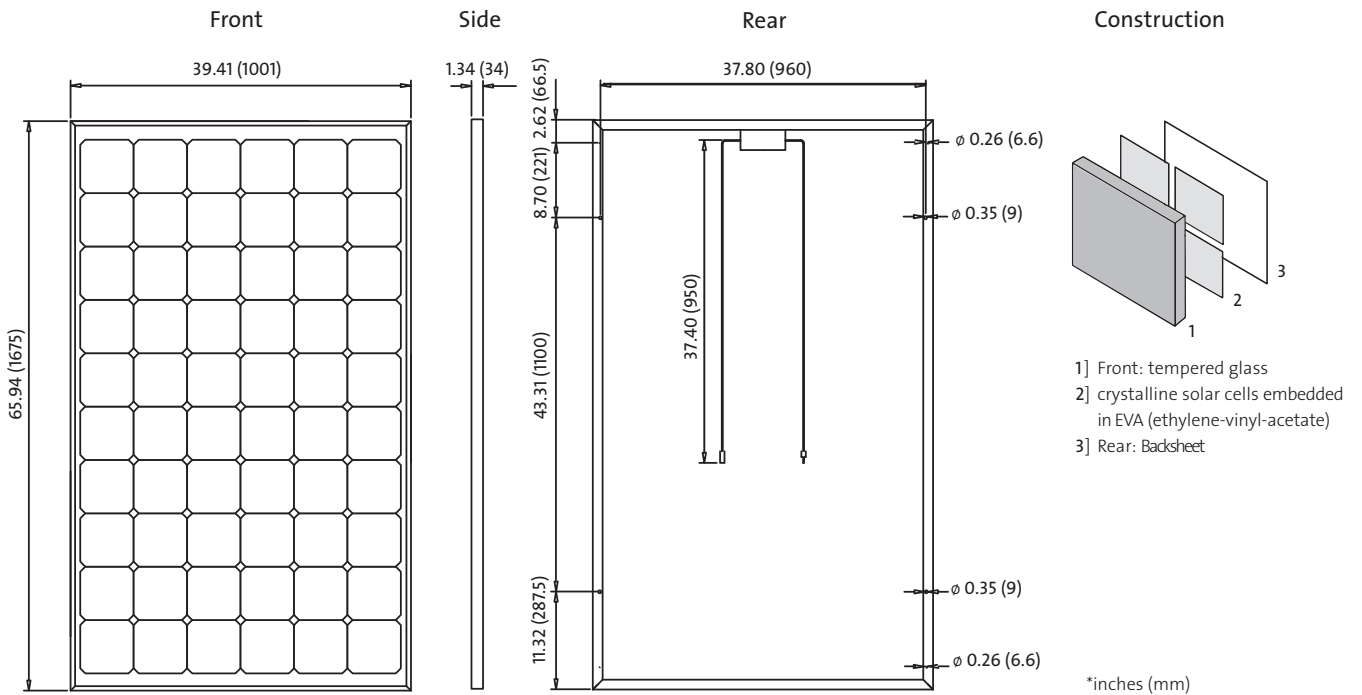

SolarWorld AG reserves the right to make specification changes without notice.
Sunmodules are manufactured in ISO 9001:2000 certified facilities.
This data sheet complies with the requirements of EN 50380

Rainwater Collection Data:

Calculations

- Total building area: 221000 sf
- Roof area: 37000 sf
- Rain water harvesting area: 18700 sf
 - Chicago average precipitation: 38.01 in/year
: (3.2 in/month)
 - Rainwater calculator A = (catchment area of building)
R = (inches of rain)
G = (total amount of collected rainwater)
(A) x (R) x (600 gallons) / 1000 = (G)
 - Total amount of collected rainwater: 35900 gal/month
Saving 430800 gallons of rainwater every year
 - Total occupation of the building: 2750 people
 - Average person uses 4.2 gal for flushing a day
 - Total use of flushing water: 10150/day
Saving 11.82% of flushing water
- Tank Construction Table and Cost

	Light duty ferrocement	Medium duty ferrocement	Heavy duty ferrocement
Tank volume	3000.00 gallons	3000.00 gallons	3000.00 gallons
Height	8.00 feet	8.00 feet	8.00 feet
Wall thickness (av)	1.00 inches	1.25 inches	2.00 inches
Roof thickness	1.00 inches	1.00 inches	1.75 inches
Floor thickness	3.00 inches	4.00 inches	5.00 inches
Roof rise/tank diameter	0.10 ratio	0.10 ratio	0.10 ratio
Floor beyond walls	1.00 inches	3.00 inches	5.00 inches
Density of material	100.00 lbs/ft3	100.00 lbs/ft3	100.00 lbs/ft3
Hoop spacing	6.00 inches	18.00 inches	24.00 inches
Major reinforcing diameter	0.13 inches	0.38 inches	0.38 inches
Note that volume under roof below is in ADDITION TO to capacity above.			
Diameter	7.99 feet	7.99 feet	7.99 feet
Diameter/ height	1.00 ratio	1.00 ratio	1.00 ratio
Volume	401.02 feet Cubic	401.02 feet Cubic	401.02 feet Cubic
Volume under roof	20.29 feet	20.29 feet	20.29 feet
Volume under roof	151.80 Gallons Cubic	151.80 Gallons Cubic	151.80 Gallons Cubic
Total volume	421.31 feet	421.31 feet	421.31 feet

Radius	3.99	Feet	3.99	Feet	3.99	Feet
Roof rise	0.80		0.80	Feet	0.80	
Circumference	25.10	Feet	25.10	Feet	25.10	Feet
Roof area	50.13	feet Square	50.13	feet Square	50.13	Square feet
Wall area	200.77	feet Square	200.77	feet Square	200.77	Square feet
Total stucco area	250.89	feet Square	250.89	feet Square	250.89	Square feet
Floor area	52.24	feet	56.60	feet	61.13	Square feet
Total area	303.13		307.49	feet Square	312.02	
(cylinder)	301.02		301.02	feet	301.02	
Roof volume	4.18	Cubic feet	4.18	feet	7.31	Cubic feet
Wall volume	16.73	Cubic feet	20.91	Cubic feet	33.46	Cubic feet
Total stucco volume	20.91	Cubic feet	25.09	Cubic feet	40.77	Cubic feet
Total stucco volume	0.77	Cubic yards	0.93	Cubic yards	1.51	Cubic yards
Floor volume	13.06	feet	18.87	feet	25.47	Cubic feet
Floor volume	0.48	Cubic yards	0.70	Cubic yards	0.94	Cubic yards
Total volume	33.97	feet	43.96	feet	66.24	Cubic feet
Total volume	1.26	Cubic yards	1.63	Cubic yards	2.45	Cubic yards
Material vol/water vol	12.40	ratio	9.58	ratio	6.36	ratio
Weight of material	3,396.78	lbs	4,395.61	lbs	6,624.15	lbs
Weight of water	26,286.05	lbs	26,286.05	lbs	26,286.05	lbs
Total weight	29,682.83	lbs	30,681.66	lbs	32,910.20	lbs

- 11 tanks needed (each tank's volume : 3000gal)

- Construction Cost

Material	Unit cost	3000 gal		9,000 gal		12,000 gal	
3/8" rebar (20' pieces)	\$3.11	30	\$93.30	50	#####	60	#####
1/2" rebar (20' pieces)	\$4.98	2	\$0.00		\$0.00		\$0.00
Lath (27"x8' pieces)	\$5.36	27	#####	40	#####	50	#####
6x6x10x10 Welded Wire Mesh (7'x200' rolls)	#####	1	#####	1.25	#####	1.5	#####
1/2" Hardware cloth (4'x100' rolls)	\$39.94	1	\$39.94	1.75	\$69.90	2	\$79.88
Tie wire (big looped bundles)	\$2.60	2	\$5.20	2	\$5.20	3	\$7.80
Cement (94 lb bags)	\$5.65	18	#####	25	#####	32	#####
Plaster sand (yd3)	\$29.50	4	#####	4.5	#####	5.5	#####
Water (gal)	\$0.01	500	\$5.00	750	\$7.50	1000	\$10.00
Thoroseal/Bonsal Sure Coat (50 lb bags)	\$19.20	7	#####	10	#####	15	#####
Color (lbs)	\$2.88	5	\$14.40	7	\$20.16	10	\$28.80
Hog rings (25 lb boxes)37	\$38.40		\$0.00		\$0.00	1	\$38.40
Hog ring staples (boxes of 10,000)	\$10.00	1	\$10.00	2	\$20.00	2	\$20.00
Dobies	\$0.50	30	\$15.00	50	\$25.00	65	\$32.50
Poles	\$16.50	6	\$99.00	10	#####	15	#####
Concrete (yd3)	\$91.50	2	#####	3.5	#####	4.5	#####
Approx. cost (\$)			1,102		1,641		2,169

- One unit approximate cost is \$1,102
- **Total Construction cost is \$12,122**

Reference

- Rainwater Harvest Guide

<http://www.rain-barrel.net/rainwater-calculator.html>

- Occupancy Calculations By Architectural Building Code

An Architect's guide to building codes & standards /produced by the American Institute of Architects Building. 2nd ed. Washington, D.C.: AIA, c1990.

- Tank Calculation and Cost

<http://www.oasisdesign.net/water/storage/> And by attached excel table.

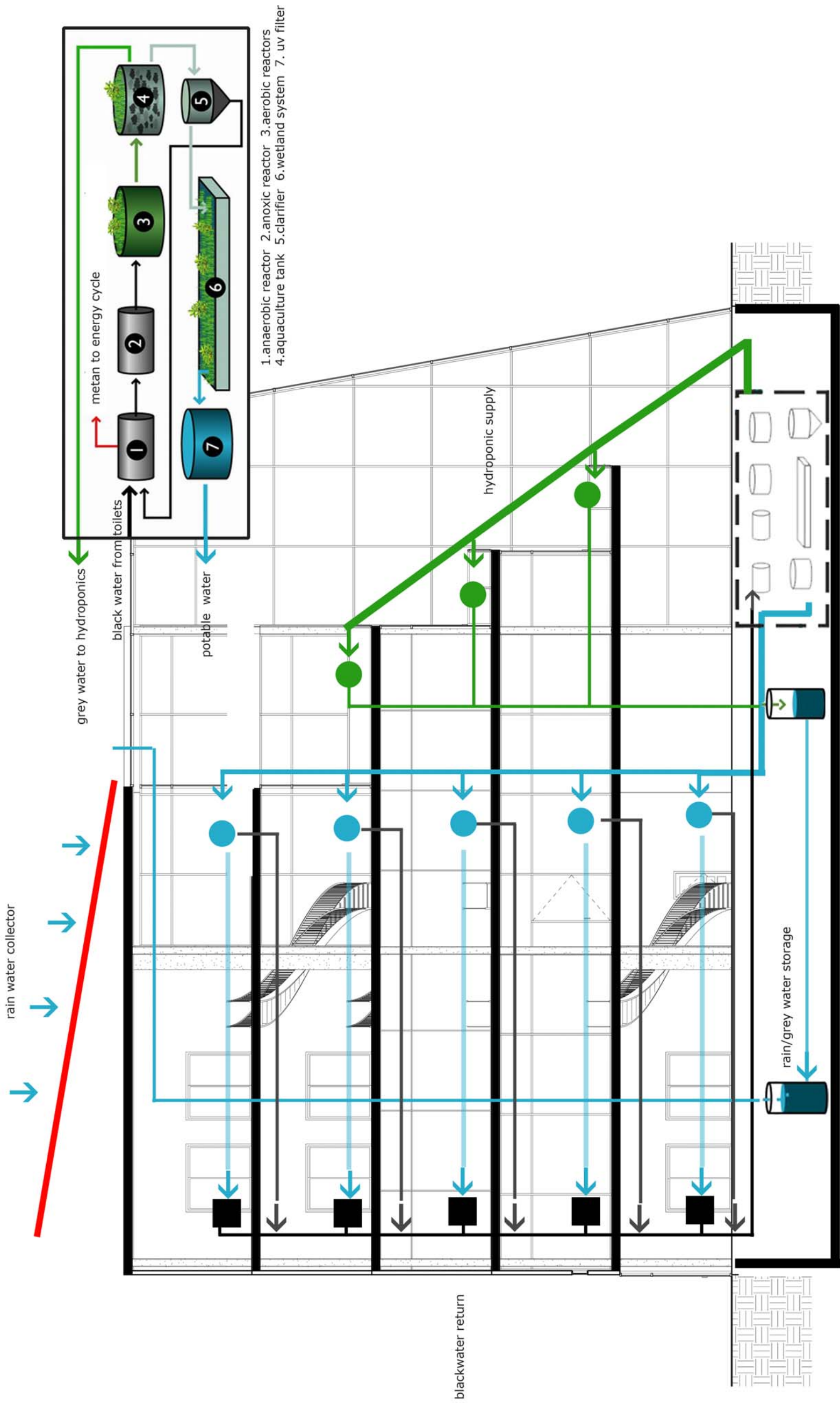

Tank Calculator

A companion to *Water Storage by Art*

Cylindrical tank with domed roof

Given tank dimensions, determine volume and surface area, and amount of material required (for ordering concrete).

Given density of tank material, determine load on ground under tank, and stress on reinforcement.

The table below is set up for ferrocement (See the *Water Storage* book for description of the construction), steel, and plastic tanks. If you would prefer to specify your own materials and construction specs, use the "Tank Calculator (generic)" worksheet.

Fill in numbers in blue under the in one or more columns. Read calculated values below.

	Light duty ferrocement	Medium duty ferrocement	Heavy duty ferrocement	Steel	Plastic
Tank volume	3000.00 gallons	3000.00 gallons	3000.00 gallons	2500.00 gallons	3000.00 gallons
Height	6.00 feet	6.00 feet	6.00 feet	6.00 feet	6.00 feet
Wall thickness (av)	1.00 inches	1.25 inches	2.00 inches	0.13 inches	0.25 inches
Roof thickness	1.00 inches	1.00 inches	1.75 inches	0.13 inches	0.25 inches
Floor thickness	3.00 inches	4.00 inches	5.00 inches	0.13 inches	0.25 inches
Roof rise/tank diameter	0.10 ratio	0.10 ratio	0.10 ratio	0.10 ratio	0.10 ratio
Floor beyond walls	1.00 inches	3.00 inches	5.00 inches	0.00 inches	0.00 inches
Density of material	100.00 lbs/ft ³	100.00 lbs/ft ³	100.00 lbs/ft ³	300.00 lbs/ft ³	60.00 lbs/ft ³
Hoop spacing	6.00 inches	18.00 inches	24.00 inches	N/A	N/A
Major reinforcing diameter	0.13 inches	0.38 inches	0.38 inches	N/A	N/A
Note that volume under roof below is in ADDITION TO to capacity above.					
Diameter	9.23 feet	9.23 feet	9.23 feet	8.42 feet	9.23 feet
Diameter/ height	1.54 ratio	1.54 ratio	1.54 ratio	1.40 ratio	1.54 ratio
Volume	401.02 Cubic feet	401.02 Cubic feet	401.02 Cubic feet	334.18 Cubic feet	401.02 Cubic feet
Volume under roof	31.24 Cubic feet	31.24 Cubic feet	31.24 Cubic feet	23.77 Cubic feet	31.24 Cubic feet
Volume under roof	233.72 Gallons	233.72 Gallons	233.72 Gallons	177.80 Gallons	233.72 Gallons
Total volume	432.26 Cubic feet	432.26 Cubic feet	432.26 Cubic feet	357.95 Cubic feet	432.26 Cubic feet

Radius	4.61 Feet	4.61 Feet	4.21 Feet	4.61 Feet
Roof rise	0.92	0.92	0.84	0.92
Circumference	28.98 Feet	28.98 Feet	26.45 Feet	28.98 Feet
Roof area	66.84 Square feet	66.84 Square feet	55.70 Square feet	66.84 Square feet
Wall area	173.87 Square feet	173.87 Square feet	158.72 Square feet	173.87 Square feet
Total stucco area	240.70 Square feet	240.70 Square feet	214.42 Square feet	240.70 Square feet
Floor area	69.27 Square feet	79.46 Square feet	55.70 Square feet	66.84 Square feet
Total area	309.98	320.16	270.11	307.54
(cylinder)	307.54	307.54	270.11	307.54
Roof volume	5.57 Cubic feet	9.75 Cubic feet	0.58 Cubic feet	1.39 Cubic feet
Wall volume	14.49 Cubic feet	28.98 Cubic feet	1.65 Cubic feet	3.62 Cubic feet
Total stucco volume	20.06	38.72	2.23	5.01
Total stucco volume	0.74 Cubic yards	1.43 Cubic yards	0.08 Cubic yards	0.19 Cubic yards
Floor volume	17.32	33.11	0.58	1.39
Floor volume	0.64 Cubic yards	1.23 Cubic yards	0.02 Cubic yards	0.05 Cubic yards
Total volume	37.38 Cubic feet	71.83 Cubic feet	2.81 Cubic feet	6.41 Cubic feet
Total volume	1.38	2.66	0.10	0.24
Material vol/water vol	11.56	6.02	127.22	67.47
Weight of material	3,737.68 lbs	7,183.14 lbs	844.10 lbs	384.43 lbs
Weight of water	26,969.21 lbs	26,969.21 lbs	22,332.82 lbs	26,969.21 lbs
Total weight	30,706.90 lbs	34,152.36 lbs	23,176.92 lbs	27,353.64 lbs
Force on soil	3.08 psi	2.98 psi	2.89 psi	2.84 psi
Force on soil	443.28 psf	429.83 psf	416.13 psf	409.27 psf
Max hoop stress	144.40 psi	72.20 psi	1,054.57 psi	577.61 psi
Rebar density	0.20% %	0.23% %		
Max hoop stress rebar alone	70,615 psi	31,385 psi		

Comments

Volume excluding space under domed roof
Height of tank walls (not roof height)

Ratio of roof rise to tank diameter. 0 for flat roof, 1/2 diameter for hemisphere
Distance that floor extends beyond walls. Used only to calculate amount of material.
Used to calculate load on ground under tank.
Vertical space between rebar hoops on ferrocement tank. For calculating hoop stress only
Diameter of reinforcing members (rebar hoops for ferrocement tank). For calculating hoop stress only

Energy Model Data:

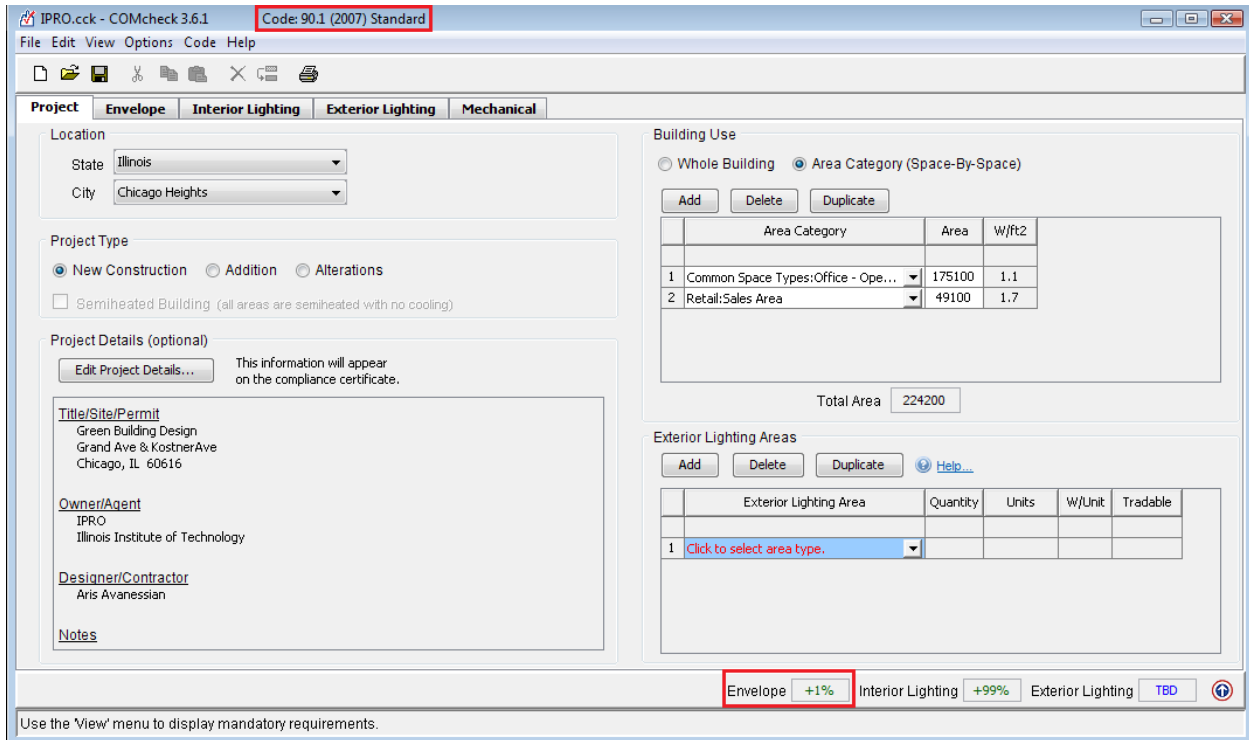

COMCheck Screenshot with ASHRAE 90.1-2007 and Envelope above 1% of code

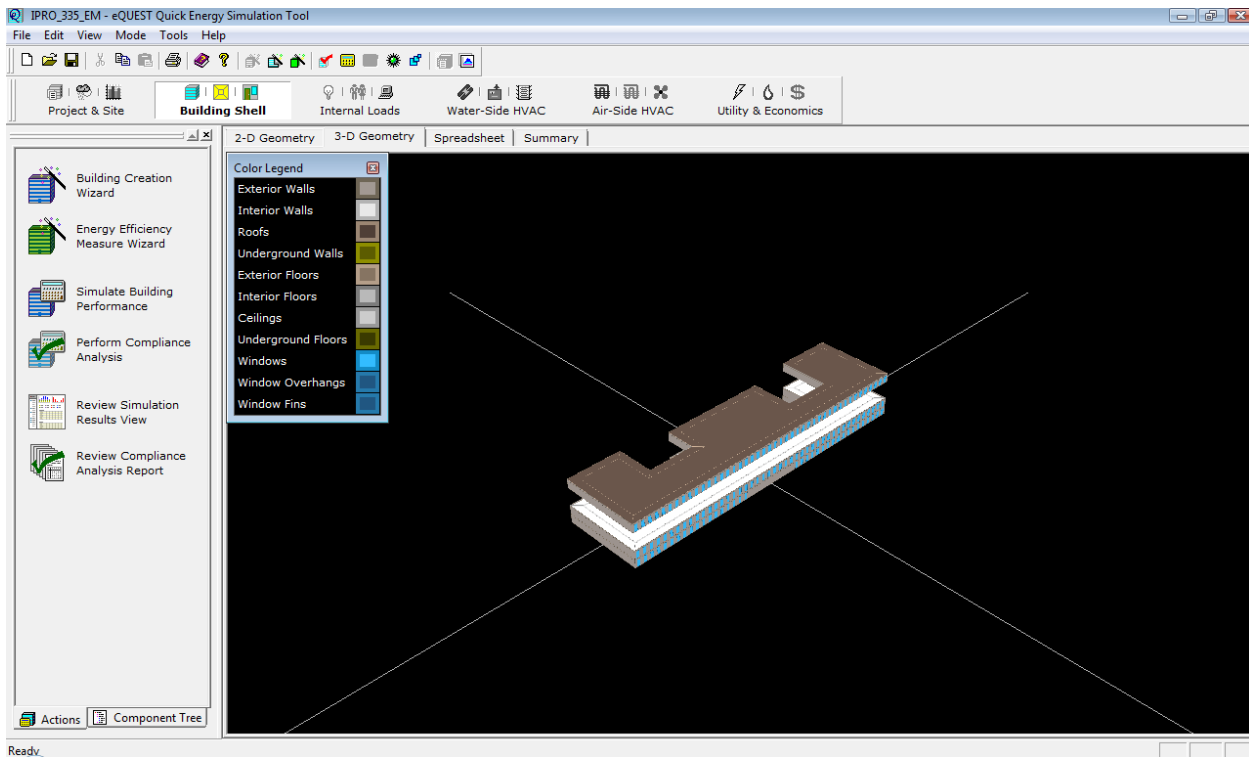

3D rendering of Model in eQuest

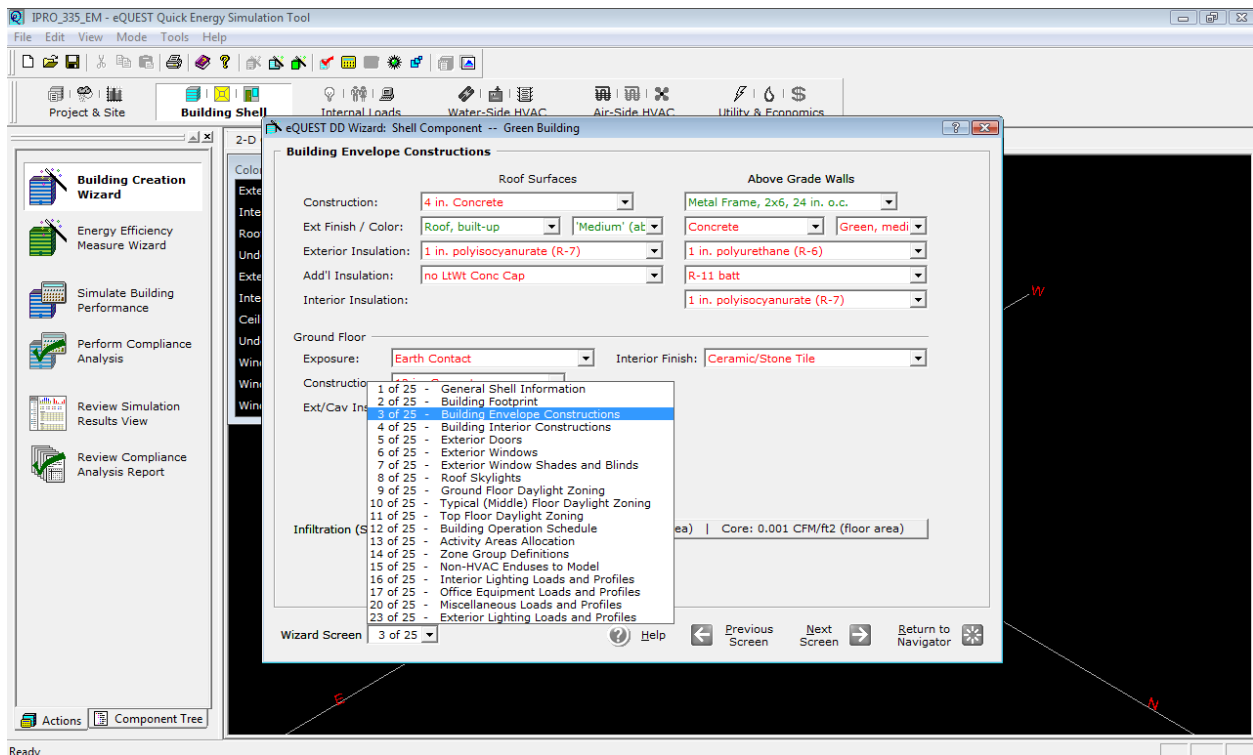

Example of inputs and details of programs input capabilities

Annual Energy Consumption by Enduse

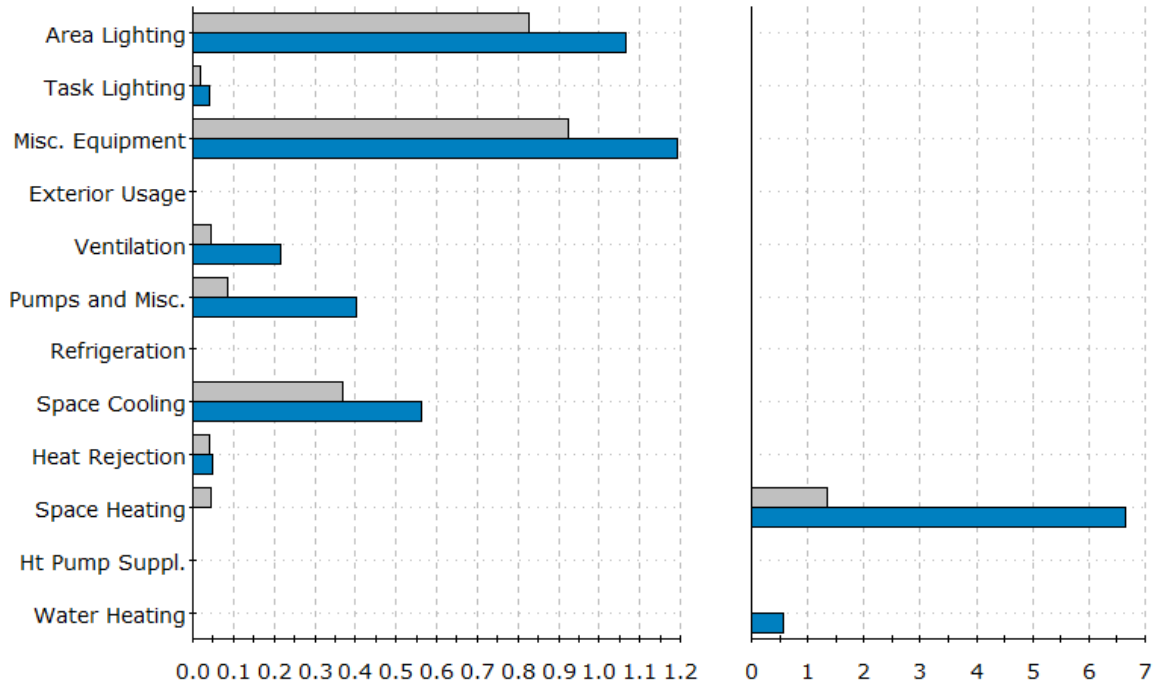

Annual Electric Consumption (kWh)

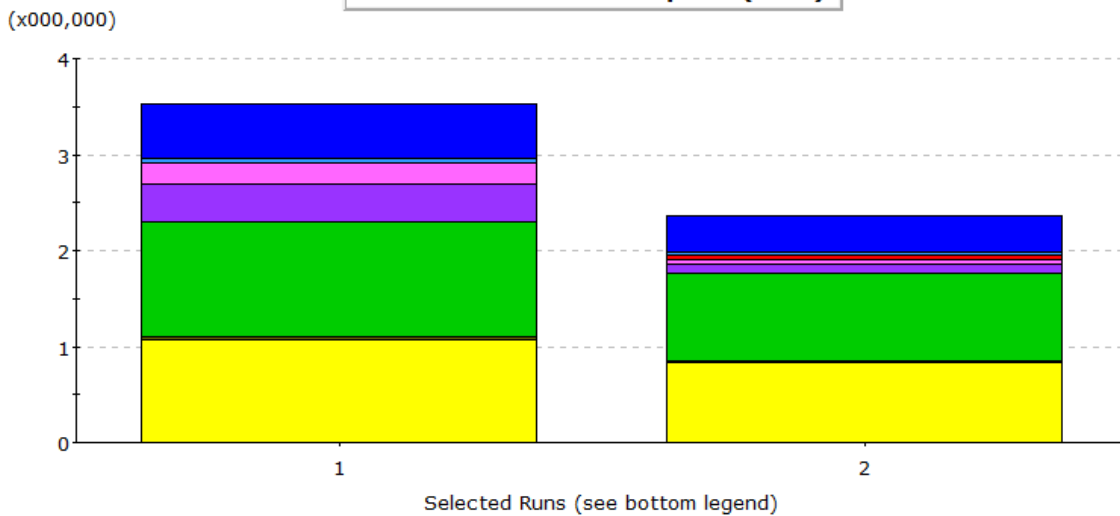

1. IPRO_335_Standard - Standard (11/23/09 @ 19:02)
2. IPRO_335_EM - Energy Efficient (11/23/09 @ 18:24)

Electric Consumption (kWh)

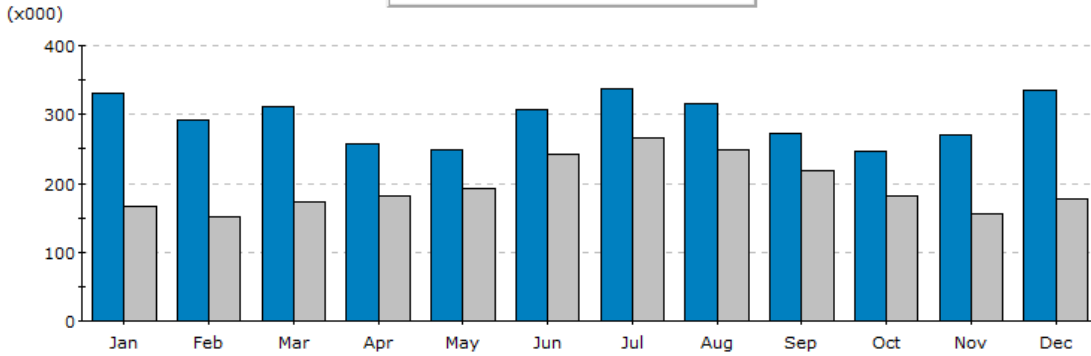

	Jan	Feb	Mar	Apr	May	Jun	Jul	Aug	Sep	Oct	Nov	Dec	Total
Run 1.	330.3	292.1	310.9	257.7	248.1	307.7	337.5	316.5	272.1	247.0	270.2	335.6	3,525.7
Run 2.	165.9	152.4	172.3	181.0	191.8	242.9	266.5	249.5	218.4	182.7	154.8	177.7	2,355.8
Run 3.													
Run 4.													
Run 5.													

- 1. IPRO_335_Standard - Standard (11/23/09 @ 19:02)
- 2. IPRO_335_EM - Energy Efficient (11/23/09 @ 18:24)

Gas Consumption (Btu)

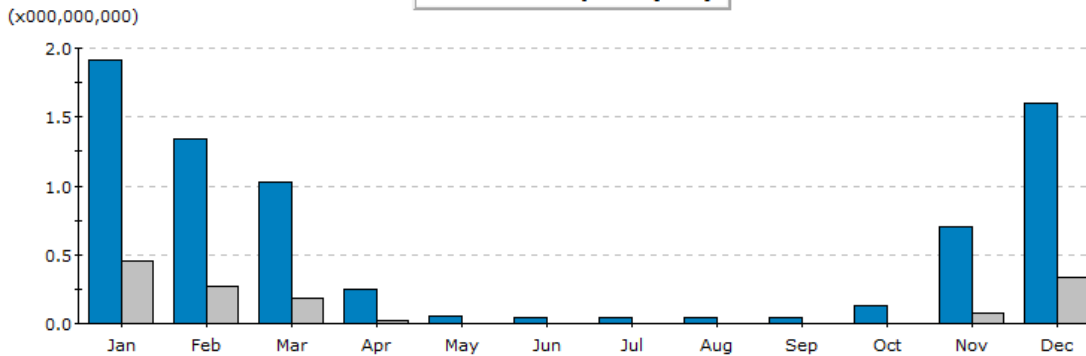

	Jan	Feb	Mar	Apr	May	Jun	Jul	Aug	Sep	Oct	Nov	Dec	Total
Run 1.	1.92	1.34	1.03	0.25	0.06	0.05	0.04	0.04	0.04	0.13	0.70	1.60	7.20
Run 2.	0.46	0.27	0.19	0.02	-	-	-	-	-	0.00	0.08	0.34	1.35
Run 3.													
Run 4.													
Run 5.													

Annual Electric Energy by Enduse (pg 1 of 4)

Annual Energy USE (kWh)		Ambient Lights	Task Lights	Misc Equip	Space Heating	Space Cooling	Heat Reject	Pumps & Aux	Vent Fans	Dom Ht Wtr	Exterior Usage	Total
0	Base Design	--	--	--	--	--	--	--	--	--	--	--
1	0+-Standard	1,064,919	39,645	1,193,629	0	561,606	47,928	401,289	216,727	0	0	3,525,743

Annual Energy Coincident Demand (kW)		Ambient Lights	Task Lights	Misc Equip	Space Heating	Space Cooling	Heat Reject	Pumps & Aux	Vent Fans	Dom Ht Wtr	Exterior Usage	Total
0	Base Design	--	--	--	--	--	--	--	--	--	--	--
1	0+-Standard	323.8	14.7	327.2	0.0	513.3	79.6	87.7	68.8	0.0	0.0	1,415.2

Annual Energy Non-Coincident Demand (kW)		Ambient Lights	Task Lights	Misc Equip	Space Heating	Space Cooling	Heat Reject	Pumps & Aux	Vent Fans	Dom Ht Wtr	Exterior Usage	Total
0	Base Design	--	--	--	--	--	--	--	--	--	--	--
1	0+-Standard	323.8	14.7	327.2	0.0	513.3	79.6	87.7	219.2	0.0	0.0	1,415.2

Annual Energy USE (MBtu)		Misc Equip	Space Heating	Space Cooling	Heat Reject	Pumps & Aux	Vent Fans	Ht Pump Supp	Dom Ht Wtr	Exterior Usage	Total
0	Base Design	--	--	--	--	--	--	--	--	--	--
1	0+-Standard	0.0	6,636.6	0.0	0.0	0.0	0.0	0.0	563.5	0.0	7,200.1

Annual Electric Energy by Enduse (pg 1 of 4)

Annual Energy USE (kWh)		Ambient Lights	Task Lights	Misc Equip	Space Heating	Space Cooling	Heat Reject	Pumps & Aux	Vent Fans	Dom Ht Wtr	Exterior Usage	Total
0	Base Design	--	--	--	--	--	--	--	--	--	--	--
1	0+Energy Efficient	827,970	16,996	925,324	45,820	369,712	39,307	85,626	45,089	0	0	2,355,839

Annual Energy Coincident Demand (kW)		Ambient Lights	Task Lights	Misc Equip	Space Heating	Space Cooling	Heat Reject	Pumps & Aux	Vent Fans	Dom Ht Wtr	Exterior Usage	Total
0	Base Design	--	--	--	--	--	--	--	--	--	--	--
1	0+Energy Efficient	263.2	6.6	277.9	0.0	598.7	133.7	43.2	20.0	0.0	0.0	1,343.4

Annual Energy Non-Coincident Demand (kW)		Ambient Lights	Task Lights	Misc Equip	Space Heating	Space Cooling	Heat Reject	Pumps & Aux	Vent Fans	Dom Ht Wtr	Exterior Usage	Total
0	Base Design	--	--	--	--	--	--	--	--	--	--	--
1	0+Energy Efficient	291.4	6.6	277.9	125.4	598.7	141.6	43.2	20.0	0.0	0.0	1,343.4

Annual Energy USE (MBtu)		Misc Equip	Space Heating	Space Cooling	Heat Reject	Pumps & Aux	Vent Fans	Ht Pump Supp	Dom Ht Wtr	Exterior Usage	Total
0	Base Design	--	--	--	--	--	--	--	--	--	--
1	0+Energy Efficient	0.0	1,347.8	0.0	0.0	0.0	0.0	0.0	0.0	0.0	1,347.8

LEED Checklist:



LEED 2009 for New Construction and Major Renovation Project Scorecard

Project Name: IPRO 335
Project Address:

Yes	?	No	21	SUSTAINABLE SITES	26 Points
-----	---	----	-----------	--------------------------	------------------

Y	Prereq 1	Construction Activity Pollution Prevention	Required	
1	Credit 1	Site Selection	1	
5	Credit 2	Development Density and Community Connectivity	5	
1	Credit 3	Brownfield Redevelopment	1	
6	Credit 4.1	Alternative Transportation - Public Transportation Access	6	
1	Credit 4.2	Alternative Transportation - Bicycle Storage and Changing Rooms	1	
3	Credit 4.3	Alternative Transportation - Low-Emitting and Fuel-Efficient Vehicles	3	
2	Credit 4.4	Alternative Transportation - Parking Capacity	2	
	Credit 5.1	Site Development - Protect or Restore Habitat	1	
	Credit 5.2	Site Development - Maximize Open Space	1	
1	Credit 6.1	Stormwater Design - Quantity Control	1	
	Credit 6.2	Stormwater Design - Quality Control	1	
	Credit 7.1	Heat Island Effect - Nonroof	1	
	Credit 7.2	Heat Island Effect - Roof	1	
1	Credit 8	Light Pollution Reduction	1	

Yes	?	No	6	WATER EFFICIENCY	10 Points
-----	---	----	----------	-------------------------	------------------

Y	Prereq 1	Water Use Reduction	Required	
2	Credit 1	Water Efficient Landscaping	2 to 4	
		2 Reduce by 50%	2	
		No Potable Water Use or Irrigation	4	
2	Credit 2	Innovative Wastewater Technologies	2	
2	Credit 3	Water Use Reduction	2 to 4	
		2 Reduce by 30%	2	
		Reduce by 35%	3	
		Reduce by 40%	4	

34	ENERGY & ATMOSPHERE	35 Points
-----------	--------------------------------	------------------

Y	Prereq 1	Fundamental Commissioning of Building Energy Systems	Required
Y	Prereq 2	Minimum Energy Performance	Required
Y	Prereq 3	Fundamental Refrigerant Management	Required
18	Credit 1	Optimize Energy Performance	1 to 19
		Improve by 12% for New Buildings or 8% for Existing Building Renovations	1
		Improve by 14% for New Buildings or 10% for Existing Building Renovations	2
		Improve by 16% for New Buildings or 12% for Existing Building Renovations	3
		Improve by 18% for New Buildings or 14% for Existing Building Renovations	4
		Improve by 20% for New Buildings or 16% for Existing Building Renovations	5
		Improve by 22% for New Buildings or 18% for Existing Building Renovations	6
		Improve by 24% for New Buildings or 20% for Existing Building Renovations	7
		Improve by 26% for New Buildings or 22% for Existing Building Renovations	8
		Improve by 28% for New Buildings or 24% for Existing Building Renovations	9
		Improve by 30% for New Buildings or 26% for Existing Building Renovations	10
		Improve by 32% for New Buildings or 28% for Existing Building Renovations	11
		Improve by 34% for New Buildings or 30% for Existing Building Renovations	12
		Improve by 36% for New Buildings or 32% for Existing Building Renovations	13
		Improve by 38% for New Buildings or 34% for Existing Building Renovations	14
		Improve by 40% for New Buildings or 36% for Existing Building Renovations	15
		Improve by 42% for New Buildings or 38% for Existing Building Renovations	16
		Improve by 44% for New Buildings or 40% for Existing Building Renovations	17
		18 Improve by 46% for New Buildings or 42% for Existing Building Renovations	18
		Improve by 48%+ for New Buildings or 44%+ for Existing Building Renovations	19
7	Credit 2	On-Site Renewable Energy	1 to 7
		1% Renewable Energy	1
		3% Renewable Energy	2
		5% Renewable Energy	3
		7% Renewable Energy	4
		9% Renewable Energy	5
		11% Renewable Energy	6
		7 13% Renewable Energy	7
2	Credit 3	Enhanced Commissioning	2
2	Credit 4	Enhanced Refrigerant Management	2
3	Credit 5	Measurement and Verification	3
2	Credit 6	Green Power	2



LEED 2009 for New Construction and Major Renovation Project Scorecard

Project Name: IPRO 335
Project Address:

Yes ? No
Yes ? No

5 MATERIALS & RESOURCES 14 Points

Y	Prereq 1	Storage and Collection of Recyclables	Required
1	Credit 1.1	Building Reuse - Maintain Existing Walls, Floors and Roof	1 to 3
		Reuse 55%	1
		Reuse 75%	2
		Reuse 95%	3
1	Credit 1.2	Building Reuse - Maintain Interior Nonstructural Elements	1
1	Credit 2	Construction Waste Management	1 to 2
		50% Recycled or Salvaged	1
		75% Recycled or Salvaged	2
1	Credit 3	Materials Reuse	1 to 2
		Reuse 5%	1
		Reuse 10%	2
1	Credit 4	Recycled Content	1 to 2
		10% of Content	1
		20% of Content	2
2	Credit 5	Regional Materials	1 to 2
		10% of Materials	1
		20% of Materials	2
1	Credit 6	Rapidly Renewable Materials	1
1	Credit 7	Certified Wood	1

15 INDOOR ENVIRONMENTAL QUALITY 15 Points

Y	Prereq 1	Minimum Indoor Air Quality Performance	Required
Y	Prereq 2	Environmental Tobacco Smoke (ETS) Control	Required
1	Credit 1	Outdoor Air Delivery Monitoring	1
1	Credit 2	Increased Ventilation	1
1	Credit 3.1	Construction Indoor Air Quality Management Plan - During Construction	1
1	Credit 3.2	Construction Indoor Air Quality Management Plan - Before Occupancy	1
1	Credit 4.1	Low-Emitting Materials - Adhesives and Sealants	1
1	Credit 4.2	Low-Emitting Materials - Paints and Coatings	1
1	Credit 4.3	Low-Emitting Materials - Flooring Systems	1
1	Credit 4.4	Low-Emitting Materials - Composite Wood and Agrifiber Products	1
1	Credit 5	Indoor Chemical and Pollutant Source Control	1
1	Credit 6.1	Controllability of Systems - Lighting	1
1	Credit 6.2	Controllability of Systems - Thermal Comfort	1
1	Credit 7.1	Thermal Comfort - Design	1
1	Credit 7.2	Thermal Comfort - Verification	1
1	Credit 8.1	Daylight and Views - Daylight	1
1	Credit 8.2	Daylight and Views - Views	1

1 INNOVATION IN DESIGN 6 Points

1	Credit 1	Innovation in Design	1 to 5
		Innovation or Exemplary Performance	1
		Innovation or Exemplary Performance	1
		Innovation or Exemplary Performance	1
		Innovation	1
		Innovation	1
1	Credit 2	LEED [®] Accredited Professional	1

REGIONAL PRIORITY 4 Points

1	Credit 1	Regional Priority	1 to 4
		Regionally Defined Credit Achieved	1
		Regionally Defined Credit Achieved	1
		Regionally Defined Credit Achieved	1
		Regionally Defined Credit Achieved	1

82 PROJECT TOTALS (Certification Estimates) 110 Points

Certified: 40-49 points Silver: 50-59 points Gold: 60-79 points Platinum: 80+ points