

DECEMBER 1st, 2006

I PRO 345

BUILDING A NOVEL MOBILE PROCESS
FOR REMEDIATING CONTAMINATED SOIL



FALL 2006 I PRO

ILLINOIS INSTITUTE OF TECHNOLOGY



TABLE OF CONTENTS

1. INTRODUCTION	4
2. BACKGROUND	4
3. PURPOSE	5
4. OBSTACLES	5
5. RESULTS	7
5.1 Supercritical Fluid Extraction	7
5.2.1 Furnace.....	11
5.2.2 Fluidized Bed	15
5.2.3 Cyclone Separation	23
5.2.4 Baghouse Filter	25
5.2.5 Adsorption.....	26
5.2.6 Condenser	33
5.3 Cost Analysis	34
5.4 Safety and Hazard analysis	37
5.5 Definitions and units of select parameters and variables.....	39
5.6 Physical properties of soil.....	39
5.7 Work to be done going forward.....	40
6. RECOMMENDATIONS	40
7. REFERENCES	41
8. ACKNOWLEDGEMENTS	41

LIST OF TABLES

Table 1: Mole balance of components in the furnace	13
Table 2: Settling Velocity for different particle sizes	20
Table 3: Mole Fractions of components of Fluidized Bed Effluent	27
Table 4: Particle Size Distribution & Mass Percent	28
Table 5: Cyclone Conditions	29
Table 6: Sizing for the Cyclone	29
Table 7: Physical Parameters and Sizing for the Baghouse.....	30
Table 8: Bag House Conditions	31



TABLE OF FIGURES

Figure 1:HYSIS Simulation for the SCF compressor.....	9
Figure 2: Supercritical fluid extraction using CO ₂ as solvent.....	9
Figure 3: Overall Process flow diagram	11
Figure 4: Overall Process Flow diagram by unit operation	11
Figure 5: The effect of flow rate on a packed bed	16



1. INTRODUCTION

Since the 1970's Americans have recognized the harmfulness of industrial pollution on human quality of life. A major concern of many Americans today is the effect of pollutants known as Polychlorinated Biphenyls (PCBs). Once found in capacitors and transformers, PCBs have been released from waste sites and have affected local wildlife, most notably fish populations. Humans exposed to PCBs have encountered liver problems, as well as birth defects. Two prominent sites affected by PCB exposure in the Chicagoland area include Waukegan Harbor, and the Altgeld Gardens housing development in Chicago's far south side. As a response to current PCB issues, IIT has launched IPRO 345, a multidisciplinary project for the design of a mobile process for PCB clean up. Using a fluidized bed, the design team has developed a (GIVE BRIEF INTRO TO PROCESS) process with the ability to intake soil, process it, and produce a 99.9% PCB-free product. In addition to the design of the process, the project also includes a feasibility study and cost estimate of services as well as background information on the effects of PCBs.

2. BACKGROUND

For many years, PCBs were used in industrial settings as insulating fluids in transformers, capacitors and other electrical equipment. Manufactured under their industrial trade name, Aroclor, PCBs were used because of their chemical stability, non flammability, high boiling point, and insulating properties (EPA.gov). Although, many different types of Aroclor were produced, the design of our project focused on the most common type, Aroclor 1254.

In 1976, congress passed section 6(e) of the Toxic Substances Control Act. This banned the production, processing, and distribution of PCBs. By the time production of PCBs officially stopped in 1977, over 1.5 billions pounds had been produced (EPA.gov). The majority of modern contamination comes from improper disposal of old equipment. Since some electrical components manufactured using PCBs have useful lifetimes of thirty years or more, contamination is still an important issue today.

What makes PCBs dangerous is their effect on the human body. The United States Environmental Protection Agency recognizes that they show a link with cancer, particularly in the liver. In addition, exposure to PCBs have negative health effects on the human



developmental process, and the endocrine, nervous and immune systems. Humans can be exposed to PCBs in several ways. Often fish from contaminated waters contain unsafe amounts of PCBs. The long-term health effects from eating contaminated fish are unknown, but it likely causes damage to fetuses, and increased cancer risk. Nursing mothers may also pass PCBs to infants through breast milk. Less often, humans may have contact with PCBs through direct skin contact or inhalation. In these cases, reported symptoms included lesions, rashes, and burning eyes and skin.

Clearly, there is no debate over whether to clean up contaminated sites. As a society that values human life, we cannot fail to act on a problem capable of affecting so many people. Therefore the question becomes not if to act, but how to act. This is the purpose of IPRO 345, finding the best way to transport a process for remediating contaminated soil.

3. PURPOSE

The purpose of IPRO 345 was to design a mobile process for the remediation of contaminated soil. To aid in the design, the team was initially expected to research the industrial uses of PCBs in the United States, as well as their chemistry and cancer causing properties. In addition, the team researched contaminated sites, most importantly those closest to the IIT campus. For the novelty of the design of the project, the team was to develop a highly mobile process that could be transported to various clean-up sites. HYSYS, computer simulation software, was used to model the effectiveness of the process. As a final step, to investigate the feasibility of the project, the team examined equipment size, capital cost and operating cost of the project.

4. OBSTACLES

- I. We tried to go to the EPA office downtown (they were closed and had moved with no forwarding contact information) and we also read several case studies on the Waukegan Harbor site but nothing provided detailed properties of the sand at the sight. For example we needed to know the soil particle distribution and the bulk density at fluidization. These could easily have been accomplished in a soil particle analysis lab with a soil sample and a number of calibrated sieves. However we could not travel to Waukegan



Harbor to obtain a sample. We overcame this obstacle by assuming an average value for the pertinent properties of sand that were well within the acceptable range.

- II. HYSIS did not have PCB nor Sand in its components database. The design team had to create sand and PCB by using various physical and chemical properties. It took over half a day of continuous work to manipulate the interior workings of HYSIS.
- III. In the first phase the sheer amount of research accumulated proved to be difficult to organize. The team overcame this by dividing up the tasks associated with the Project Plan. We also created folders in iGROUPS for each research topic or area.
- IV. PCB becomes even more unstable and hazardous at very high temperatures. The design sub-team has to work around this when choosing the design parameters for the fluidized bed contactors. For this reason, we have chosen a temperature just around the boiling point of PCB (370⁰ F) as the operating temperature of the column.
- V. Lack of experience or expertise with the project topic is slowing the pace of the design process. We end up spending a lot of time being stuck on several possibilities that look equally rewarding. To overcome this particular barrier we have sought out more specific help from our faculty in charge and also an industry expert. We have scheduled time to present our detailed design to them for critiquing.



5. RESULTS

What are the different remediation options available?

- I. Incineration: results in more toxic and unstable material
- II. Excavation and land filling: Not acceptable according to United Nations Environmental Programme (UNEP) standards
- III. Dechlorination: Only for 10% or less PCB contamination
- IV. Supercritical Fluid Extraction: Emerging technology not yet scaled up
- V. Thermal Desorption: Widely accepted. Novel design to include mobility

5.1 Supercritical Fluid Extraction

For simplicity since there are different classes of PCBs, our design will be based on the physical properties of PCB 1254 (54% Chlorine).

An SCF is a single-phase fluid at temperature and pressure above the critical point. SCF extraction is an emerging technology in hazardous waste management with few full scale applications. In SCF extraction, organics in soils are dissolved in the SCF at elevated temperature and pressure conditions and released from the SCF at lower temperatures and pressures. There are currently no generally accepted design procedures. Each design procedure in existence is designed with specific sites in mind.

Theory of supercritical fluid applications

Fluids are normally divided into two phases; liquid and solid. However at elevated temperatures and pressures, a point is reached where this distinction is no longer apparent. The fluid is neither gas nor a liquid. This point is known as the critical point. Above the critical temperature of a compound the pure, gaseous component cannot be liquefied regardless of the pressure applied. In the supercritical environment only one phase exists. The behavior of a fluid in the supercritical state can be described as that of a very mobile liquid. The solubility behavior approaches that of the liquid phase while penetration into a solid matrix is facilitated by the gas-like transport properties. As a consequence, the rates of extraction and phase separation can be significantly faster than for conventional extraction processes.

However, unlike conventional extraction, once the conditions are returned to ambient the quantity of residual solvent in the extracted material is negligible. In other words, separation of solvent and extract is more favorable in supercritical extraction than in conventional extraction because the mass transfer was only achieved due to the supercritical nature of the solvent. Once the solvent is returned to ambient, the extract has less affinity for it.



Process

First the soil is introduced into an extraction vessel into which the extraction fluid, pressurized and heated to the critical point in a compressor is continuously loaded. Then PCB in soil dissolves in the SCF because of the peculiar properties that it has. The design is essential. The design is such that PCB has a greater affinity for the SCF than the soil and that PCB will easily transfer to the SCF from its original medium. Next the SCF and PCB matrix is expanded by passing it through a pressure reduction valve. This expansion process lowers the solubility of the organic contaminant in the SCF resulting in separation. Finally, SCF is recompressed and recycled.

Design Considerations

1. Selection of solvent:

The selection of the solvent depends on various factors such as the density difference between the fluid and PCB. The relative density of PCB is 1.5 and thus we are considering two solvents, CO₂ and Cyclohexane. Of the two, CO₂ is less toxic. Cyclohexane is prone to being explosive at its critical conditions and would require insulation of the chambers involved. Another consideration in selecting the solvent is that the lower the critical temperature and pressure of the SCF, the more cost effective the design.

The team chose CO₂ as the solvent of choice for several reasons. Firstly, CO₂ has higher mass transfer rates compared to organic solvents because it has high diffusivity and low solvent viscosity but still maintains a high density. The density of CO₂ is sufficiently high to encourage mass transfer of organic pollutant but still low enough to allow for separation down the line.

2. Pressure must be maintained at very close to critical pressure. A slight variation in reduced pressure will result in a significant change in reduced density of the chosen solvent. If this happens, it will potentially change a lot of variables in the design of the process. The process relies heavily on the density of the chosen solvent.

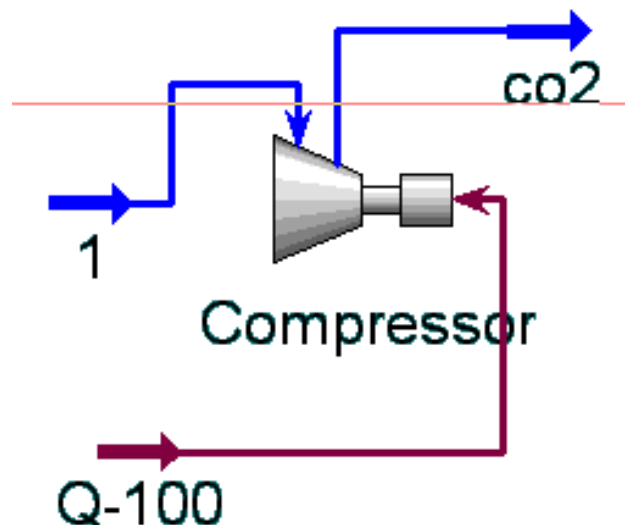



Figure 1: HYSIS Simulation for the SCF compressor

Below is the flow chart of the simulated design, using HYSIS, of the compressor process of a supercritical fluid extraction compressor using CO₂ as the solvent (Figure 1).

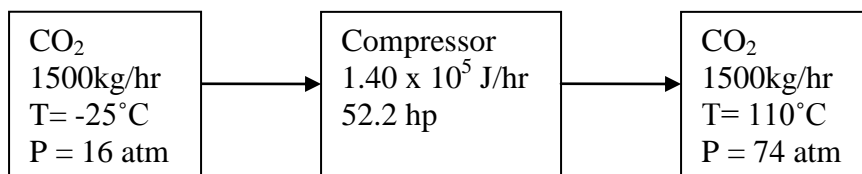

Figure 2: Supercritical fluid extraction using CO₂ as solvent.

The HYSIS simulation was done by trial and error by approximating the inlet pressure while holding the molar flow rate constant for the inlet and exit stream by entering the pressure of the exit stream. After the given parameters, the simulation would calculate the inlet temperature and the exit temperature of the CO₂ and the calculated heat flow and power of the compressor. The calculated results were as follows. The inlet CO₂ temperature was calculated to be -25°C and the desired temperature of the exit stream to be 110°C. In the HYSIS simulation the inlet/outlet molar flow rate were estimated to be 1500 kgmole/hr and a calculated inlet temperature of -25°C and an exit temperature of 110 °C. Considering that CO₂ melting point is -56°C and a boiling point of -78°C, which were well within the parameters. Under the instructor's instructions the compressor should have a horse power of approximately 40 to 60 hp for this process. The final results were as follows, the compressors heat flow was 1.40×10^5 kJ/hr and the compressors power was 52.2 hp which were well within the parameters. This was one way to use CO₂ as a solvent for the supercritical fluid extraction; however, further research is needed for a cost analysis of CO₂ as a solvent for the supercritical fluid extraction in order to determine whether this process is economical feasible for the soil remediation project.

Electrical usage for the pump

From the section above, it was found that the power requirement for the pump was 52.2hp. At a conversion rate of $1\text{hp}=0.7457\text{kW}$, this gives 38.9KW. The average cost of electricity for industrial usage is \$0.06/KWh, so this is \$2.33 per hr for 1500kg of CO₂ processed. For our design to be cost-effective, it is essential that we recycle our solvent, CO₂.



5.2 Thermal Desorption

What is Thermal Desorption?

Thermal desorption is the process of applying heat to a contaminated material to vaporize it into the gas stream. The gas stream is then treated prior to discharge to the environment.

Methodology

Typically, combustion gas is the transfer medium for the vaporized components and the fluidized bed is the contact chamber for the solid particles and the combustion gas

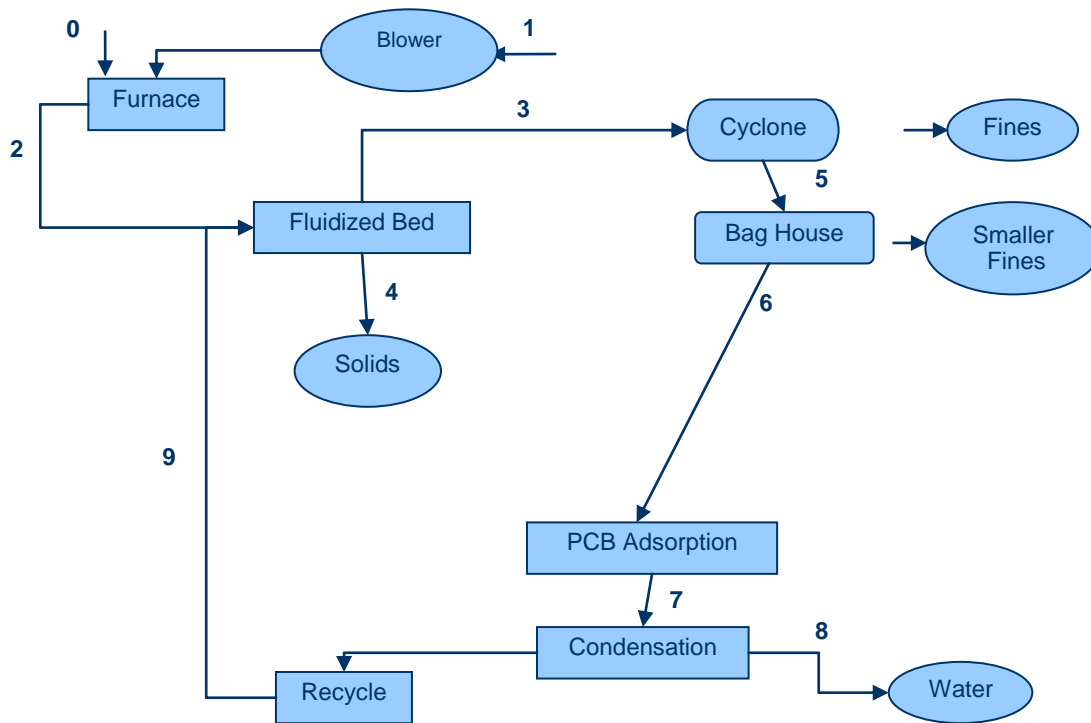



Stream-0: Feed of Methane to the furnace.

Stream-1: Feed of Air to the furnace from the blower.

Stream-2: Combustion Gases (CO₂, H₂O, N₂ and O₂)

Stream-3: Flue Gas, water, PCB and solid Fines.

Stream-4: Water free Solids. Trace of PCB.

Stream-5: Effluent of first separation unit.

Stream-6: Effluent from bag house with negligible fines

Stream-7: Water and negligible PCB.

Stream-8: Water.

Stream-9: Recycle combustion gases and water back to the fluidized bed.

Figure 3: Overall Process flow diagram

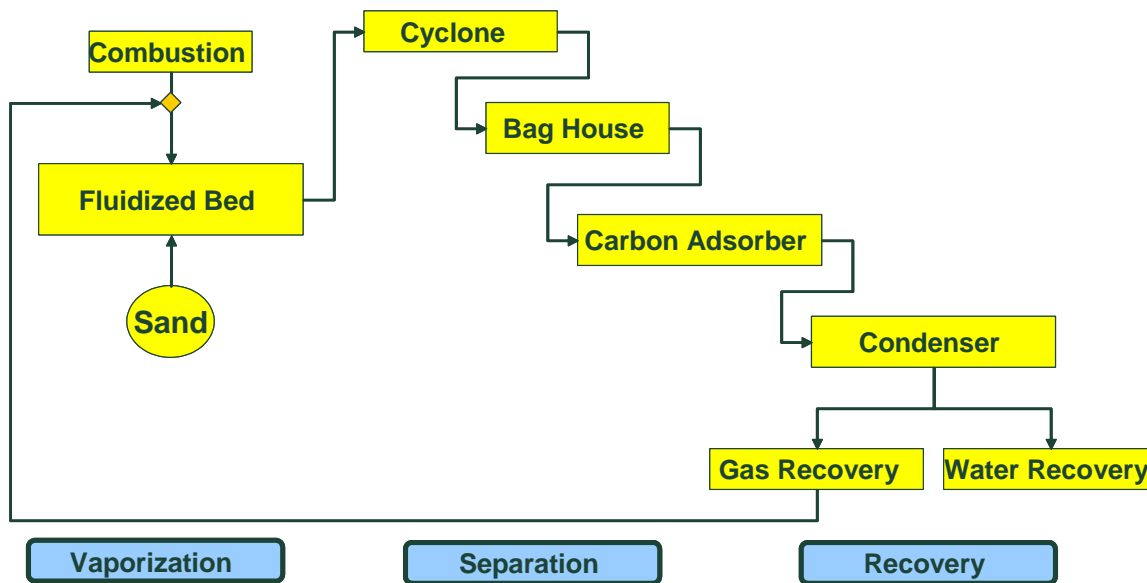
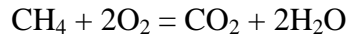

Figure 4: Overall Process Flow diagram by unit operation

5.2.1 Furnace

The amount of heat required to vaporize PCB and water present in the soil is obtained through a combustion reaction that takes place within a furnace. The reaction is:



An equal sign instead of an arrow is used here to represent complete combustion. The supply of air to the furnace is driven by a blower to provide sufficient flow to fluidize the fixed bed. Methane is injected directly into the furnace so that combustion takes place within the furnace. A 100 mol basis is assumed for the methane and according to the elementary stoichiometric relationship in the equation above, 200 mol of oxygen is necessary for complete combustion. However an excess of 400 mol of oxygen is fed to the furnace to ensure complete combustion. Rather than pure oxygen, air is fed to the furnace. Air is approximately 79% Nitrogen and 21% oxygen which means that Nitrogen, an inert gas in this reaction, is present in the flue gas stream to the fluidized bed. The furnace is operated at 1.36atm which is just above atmospheric pressure (1atm). To calculate the density of the flue gas stream, ideal conditions are assumed such that:

$$PV = nRT$$

Where P is the pressure in the furnace, T is the temperature within the furnace and R is the universal gas constant. By using the identity, density = mass/volume and after manipulation, the equation above becomes:

$$\rho_{fluegas} = \frac{P}{RT} MW_{\text{CO}_2+\text{H}_2\text{O}+\text{O}_2+\text{N}_2}$$

Where MW stands for molecular weight and $MW_{\text{CO}_2+\text{H}_2\text{O}+\text{O}_2+\text{N}_2}$ is the average molecular weight of the gas. It is calculated to be 49.8gmol/mol. The density at pressure of 1.36atm and temperature of 1800K is then calculated to be:

$$\rho_{fluegas} = \frac{49.8g/mol \times 1.36atm \times K}{82.037cm^3 \cdot atm \times 1800K} = 4.59 \times 10^{-4} g/cm^3$$

Calculating the flame temperature in the furnace



An important assumption was made in the calculation of the flame temperature. It was assumed that the furnace operates adiabatically such that the energy released by combustion is not lost but goes directly to heat up the components.

Below is a mole balance on each of the species.

Component	Number of moles into the furnace	Number of moles out of the furnace	Change in number of moles
CH ₄	100	0	-100
O ₂	1504	1504	0
N ₂	1504	1504	0
CO ₂	0	100	100
H ₂ O	0	200	200

Table 1: Mole balance of components in the furnace

Excess air and CH₄ enter separately into the furnace at 100⁰C where they mix and react. Excess air is used to completely combust CH₄. The reaction proceeds at an immeasurably slow rate and as temperature increases, the rate of oxidation reaction also increases, and measurable amounts of CO₂ and H₂O appear. The products are calculated based on the elementary stoichiometric relationship as defined by the chemical equation.

An energy balance over the system is performed recognizing the following system properties:
Adiabatic Combustion, open system ($\nabla Q = 0$)

$$\nabla \dot{H} = \dot{n}_f \times \nabla H^o_c + \sum_i n_i \times H_i(T_{out}) - \sum_i n_i \times H_i(T_{feed}) = 0$$

$$\sum_i n_i \times H_i(T_{out}) = \sum_i n_i \times H_i(T_{feed}) - \dot{n}_f \times \nabla H_{oc}$$

$$\dot{n}_f = 100 \text{ mol (CH}_4\text{)}$$



$$\nabla H_c^o = -890.36 \text{ KJ/mol}$$

$$\text{Air}(100^\circ\text{C}): H = 2.19 \text{ KJ/mol}$$

Next, the LHS and RHS are solved independently (an excel sheet showing the calculations has been appended to this report):

$$\text{LHS: } \sum_i n_i \times H_i(T_{feed}) - \dot{n}_f \times \nabla H_{oc} = 100 \times 0 + 1904 \times 2.191 - 100(-890.36)$$

$$\sum_i n_i \times H_i(T_{feed}) - \dot{n}_f \times \nabla H_{oc} = 93,209 \text{ KJ/mol}$$

$$\text{RHS: } \sum n_i \times H_i(T_{out}) = n_{H_2O} \cdot \nabla H_{H_2O}^o + \int_{25}^{T_f} n_i C_{pi} dT$$

Where T_f is the flame temperature we desire to calculate. The integral term in the RHS equation above can be further simplified based on the assumption that C_p has a very weak dependence on temperature:

$$\sum n_i \times H_i(T_{out}) = n_{H_2O} \cdot \nabla H_{H_2O}^o + \sum n_i C_{pi} \int_{25}^{T_f} dT \quad \text{----- (1)}$$

$$\Delta H_{vH_2O} = 44.013 \text{ KJ/mol}$$

Product stream enthalpy, $\sum n_i C_{pi}$

The C_p ($\text{KJ/mol}^2 \cdot ^\circ\text{C}$) of each component is calculated at 25°C from tables. The constants have already been found as illustrated here:

$$C_{PCO_2} = 36.11 \times 10^{-3} + (4.233 \times 10^{-5} \times 25) + (-2.887 \times 10^{-8} \times 85^2) = 0.037025$$

$$C_{PH_2O(g)} = 33.46 \times 10^{-3} + 0.6880 \times 10^{-5} \times 25 + 0.7604 \times 10^{-8} \times 25^2 = 0.033637$$

$$C_{PO_2} = 29.1 \times 10^{-3} + (1.158 \times 10^{-5} \times 25) + (-0.6076 \times 10^{-8} \times 21^2) = 0.029386$$

$$C_{PN_2} = 29 \times 10^{-3} + (0.7199 \times 10^{-5} \times 25) + (0.5723 \times 10^{-8} \times 25^2) = 0.029059$$



$$\sum n_i C_{p_i} = n_{O_2} C_{p_{O_2}} + n_{N_2} C_{p_{N_2}} + n_{CO_2} C_{p_{CO_2}} + n_{H_2O} C_{p_{H_2O}} = 2.939 + 32.78 + 3.717 + 6.725$$

$$\sum n_i C_{p_i} = 46.164 \text{ KJ/mol} \cdot ^\circ\text{C}$$

Substituting this value into equation (1) above and solving gives:

$$\sum n_i \times H_i(T_{out}) = n_{H_2O} \cdot \nabla H_{H_2O}^o + \sum n_i C_{p_i} \int_{25}^{T_f} dT$$

$$\sum n_i \times H_i(T_{out}) = 200 \times 44.013 \text{ KJ/mol} + 46.164 \int_{25}^{T_f} dT = 8802.6 + 46.164 T_f - (46.164 \times 25)$$

$$\sum n_i \times H_i(T_{out}) = 46.164 T_f + 7648.5$$

The above equation is then equated to the numerical result from the LHS to solve for T_f .

$$T_f = 1853.37^\circ\text{C}$$

Heat, Q needed to vaporize the PCB

In order to calculate the heat required to vaporize PCB, the heat capacities of the different components of the stream going into the fluidized bed were found and assumed to be constant, an energy balance was calculated based on the inlet stream heat enthalpies and the product stream enthalpies exiting the furnace.

$$Q = (\dot{m} C_p dT)_{solid} + (\dot{m} C_p dT)_{H_2O} + (\dot{m} C_p dT)_{PCB} + \nabla H_{PCB} + \nabla H_{H_2O}$$

$$Q = (6.865 \times 219.2 \times (204 - 25)) + (1009.16 \times 1.868 \times (204 - 25)) + (0.06885 \times 10^{-3} \times 0.00257 \times (204 - 25)) + 126.9 + 2444$$

$$Q = 2.697 \times 10^8 \text{ KJ/hr}$$

5.2.2 Fluidized Bed

When a fluid such as a gas or a liquid is allowed to infiltrate upward through a bed of particulate solids, the structure of the bed remains unchanged until a certain velocity is reached. This velocity is known as the minimum fluidization velocity. As the fluid flow is increased, the



pressure drop in the bed also increases until it reaches a maximum value corresponding to the bed weight per unit area. It is important to note that in this state of fluidization, heavy objects tend to sink while light objects tend to float. Also, fluidization allows the solid to flow like a liquid through an outlet. This means that larger particles in the soil will sink and may be collected easily through the bottom of the bed. The situation where solid particles are entrained, suspended or carried along by the fluid flow corresponds to a state called pneumatic transport.

When the fluid is a gas, such as in our case, bubbling is predominant. The minimum bubbling velocity is the velocity at which the first bubbles begin to appear. Pneumatic transport of solid particles by the gas stream occurs at and above the particle terminal velocity. It is undesirable to have pneumatic transport and should be avoided as much as possible. Estimation of the onset of the fluidization velocity is essential because it is the most important fundamental design parameter in fluidization.

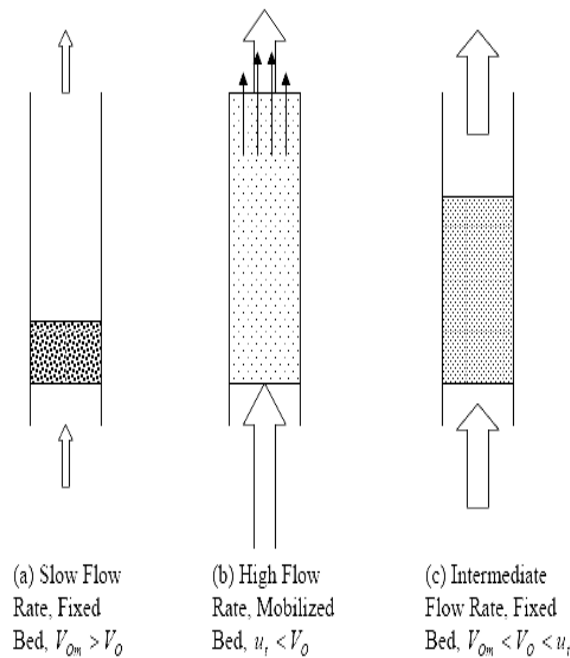

Figure 5: The effect of flow rate on a packed bed

Dynamics at fluidization:

In order to properly design a fluidized bed to extract PCB from soil, the soil density of the sample at the site must be determined. For simplicity sake since we are not designing for a



particular site, we pick a soil density that is applicable to a wide range of soils. Void fraction is then calculated thus:

$$\text{Void Fraction} = 1 - \frac{\text{Bulk Density}}{\text{Particulate density}}$$

¹Where Bulk Density of soil is 1.3g/cm^3
Particulate density is app. 2.0g/cm^3

The void fraction was found to be 0.35. Since the particle density is greater than the density of the fluid to be used to fluidize the bed, we are operating under normal fluidization conditions.

Parameters

Independent variables:

Fluid(flue gas) properties

Density = $4.59 \times 10^{-4} \text{ g / cm}^3$

Viscosity = 0.08cP

Particle(soil) properties

Density = 2.0g/cm^3

Size = $<2000 \mu\text{m}$ (varies)

Shape = *assumed spherical

Porosity = 0.35

System Parameters

Fluid Flow direction = upward

Vessel geometry = Cylindrical and symmetric

Operating linear velocity = 3.89m/s

Temperature = 400F (low temperature thermal desorption)

Pressure = 20psia (1.36atm)

¹ http://interactive.usask.ca/Ski/agriculture/soils/soilphys/soilphys_depo.html



Dependent Variables:

Minimum fluidization velocity = 0.389m/s

Particulate distribution

Soil particles range widely in size from clay (less than 0.0039 mm diameter) to silt (0.0039 mm to 0.0625 mm) to sand (0.0625 mm to 2.000 mm). Particles larger than 2 mm in diameter are generally classified as gravel.¹ Our site primarily contains soil classified as loamy sand. Using the soil texture triangle, the mass distribution for this type of soil is 10% Clay, 5% silt and 85% sand. With this information the particulate diameter, D_p may be calculated.

$$D_p = \frac{1}{\sum \left(\frac{x_i}{dp_i} \right)}$$

Where dp_i is the particle diameter for clay, silt and sand in turn and x_i is the corresponding mass fraction. In the absence of an experimental sample, dp_i for each soil type is obtained by taking a weighted average over the specified range above.

$$D_p = \frac{1}{\frac{0.85}{1850} + \frac{0.1}{3.5} + \frac{0.05}{33}} = 32.7 \mu m$$

To calculate the minimum velocity required to fluidize the fixed bed, we use the widely accepted Leva equation.

$$V_{mf} = \left[\frac{g(\rho_p - \rho_f)D_p^{1.94}}{1430\rho_f\mu^{0.94}} \right]^{\frac{1}{1.06}}$$

Where μ is the viscosity of the flue gas. As can be seen, the viscosity of the flue gas must be computed. This is done by solving the Boltzmann equation. The Boltzmann equation is solved using a Sonine polynomial expansion. The Sonine polynomial expansion consists of a series of



computations that are difficult to solve analytically. However, a computer simulation application can be used for such calculations. Under the given conditions i.e. temperature of 1800°C and 1.36atm , the viscosity of the multi-component gas described above was found to be 0.08cP (centipoises). The minimum fluidization velocity was then found:

$$V_{mf} = \left[\frac{98000(2.0 - 0.000459)0.00327^{1.94}}{1430 \times 0.000459 \times 0.08^{0.94}} \right]^{\frac{1}{1.06}} \times \frac{1\text{m}}{100\text{cm}} = 0.389 \frac{\text{m}}{\text{s}}$$

Sizing the bed

To calculate the diameter of the bed assuming perfect sphericity and smooth surface of the soil:

$$D = \sqrt{\frac{4\dot{V}}{\pi V}}$$

Where V_{dot} is the volumetric flow rate of the combustion gas coming into the fluidized bed and V is the linear velocity, 3.89m/s .

$$V_{\text{gas}} = \frac{\dot{m}_{\text{gas}}}{\rho_{\text{fluegas}}} = \frac{3200.76}{4.59 \times 10^{-4}} = 6917.7\text{m}^3 / \text{hr}$$

$$\mathbf{D = 2.52\text{m}}$$

The Bed height is determined by a number of factors such as:

1. Gas-contact time
2. L/D ratio required to provide staging
3. Maximum allowable length on a flatbed truck
4. Solids-retention time

Generally, bed heights are not less than 0.3 m (12 in) or more than 15m (50 ft).

Solids separation in the fluidized bed



As mentioned before, in a fluidized bed lighter particles tend to get blown out through the top of the bed by the flue gas. Depending on the velocity and intensive properties of the flue gas coming in as well as the size and shape of particles within the bed, we can determine what particles get blown out through the top. The governing law for this is known as Stokes' Law. For dilute suspensions, Stokes' Law predicts the settling velocity of small spheres in either air or water. Stokes' Law is given by:

$$w = \frac{2(\rho_p - \rho_f)gr^2}{9\mu}$$

where w is the settling velocity of the particle, g is the acceleration due to gravity and r is the radius of the particle. Other variables remain as defined previously. Using a chart provided in Perry's handbook for specific gravity of 2, the following values were obtained for the terminal velocity:

Particle Type	Upper limit of Particle Size μ m	Settling Velocity cm/s
Sand	1850	1000
Silt	33	50
Clay	3.5	0.05

Table 2: Settling Velocity for different particle sizes

With a flow rate of 389cm/s, the particles that get blown out through the top of the fluidized bed have a mean particle diameter of 18microns with a standard deviation of 15 microns. This was the basis for the HYSIS simulation of the cyclone feed stream.

Vapor Pressures and Mole Fraction:

The feed consists of 10,000ppm PCB, 14.7 weight % H₂O and 17,000lbs of soil. Raoult's law was used to find the molar fraction of PCB and H₂O in the vapor phase within the fluidized bed. From charts, the vapor pressures of PCB and H₂O were computed at the fixed temperature entering the bed. The mole fractions of PCB and H₂O in the soil were estimated at 1 each



because they are present in the soil as pure components and are thus insoluble. Raoult's Law states that:

$$P = x_i P_i$$

Where P is the total system pressure, P_i is the partial pressure and X_i is the mole fraction of PCB and water in turn.

From steam tables @ 204.4⁰C:

$$P_{H_2O} = P = 17 \text{ bar (16.78 atm)}$$

$$P_{PCB} = 0.02 \text{ atm}$$

$$X_{H_2O} = 1$$

$$X_{PCB} = 1$$

The gas phase in the fluidized bed had 50% saturation. The vapor fraction of PCB and H₂O was calculated using Dalton's law in order to know how much water gets vaporized in the total gas. Dalton's Law states that:

$$P_i = y_i P_{tot}$$

Where y_i is the vapor fraction of water and where P_{tot} is the total pressure and is assumed to be 20psia. The partial pressure of PCB was calculated using the molecular weight of PCB (360.6g/mol) multiplied by the molecular fraction of PCB in the soil (0.010). Using Raoult's Law:

$$P_i = x_i P_{tot} = 0.010 \times 0.02 = 2.0 \times 10^{-4} \text{ atm}$$

$$y_{PCB} = \frac{P_{PCB}}{P_{tot}}$$

To calculate the mass fraction of water for our soil sample with 14.7% moisture,



$$\frac{13000 \text{ ton} \times 14.7}{\text{hr} \times 100} = 2170 \frac{\text{ton}}{\text{hr}}$$

The partial pressure of H₂O calculated earlier (P_{H₂O} = 16.78atm) is divided by the total pressure of 2psia.

$$y_{H_2O} = \frac{P_{H_2O}}{P} = \frac{16.78}{2} = 9.39$$

Exit temperature of the fluidized bed

$$Q = \dot{m} C_p dT$$

Where Q is the amount of heat required to volatize PCB.

$$2.679 \times 10^8 = 1016.46 \times 46.14 \times (1853 - T_{exit})$$

$$T_{exit} = 389.6^\circ\text{C}$$

Advantages of fluidized bed

1. High rate of heat transfer under isothermal operating conditions
2. Maintenance cost is low since there is no moving part
3. Unit can be mounted vertically to save space
4. Ease of control despite large-scale application

Disadvantages of fluidized bed

1. Elutriation of fines are inevitable and fine-sized particles get blown out through the top
2. The hydrodynamic features of a fluidized bed are complex and hence modeling and scale-up are difficult.
3. Sticky materials in the soil could defluidize the bed



PHYSICAL SEPARATION OF SOIL FINES OR DUST

Purpose of soil fine removal and collection

For this project, soil fines removal and collection is very important for the following reasons:

1. Air-pollution control
2. Equipment-maintenance reduction
3. Safety- or health-hazard elimination

The operations in dust collection are separation of the gas-borne particles from a gas stream by deposition on a collecting surface, the retention of the deposit on the surface, and the removal of the deposit from the surface for recovery or disposal. The separation requires a force that produces a motion of a particle relative to the gas and gas retention time enough for the particle to migrate into the collecting surface. The mechanisms of deposition that are applied in dust collectors are gravitational settler, flow-line interception, inertial deposition, diffusion deposition, and the cyclone. The gravitational settler is large and bulky and can handle only particle range 40-100 μm . As for the cyclone it uses centrifugal force, it's more efficient under heavy loads and has a particle range 15-50 μm . The cyclone was chosen as a multi-tube or multi cyclone (3 cyclones in parallel). This is due to the large volume of gas being treated in this process. The large particles are removed in the first cyclone while second one has a lower efficiency compared to the first. This is shown to have high efficiencies of 90 % for 5 to 10 microns.

5.2.3 Cyclone Separation

The most commonly used type of soil fines collection equipment is the cyclone, in which solids-laden gas enters a cylindrical or conical chamber tangentially at one point and leaves through the top with most of the solid particles leaving out through the bottom. The dust particles, by virtue of their inertia, will tend to move toward the outside separator wall, from which they are led into a receiver. A cyclone is essentially a settling chamber that uses centrifugal acceleration for separation.



Within the range of their performance capabilities, cyclone collectors offer one of the least expensive means of soil fines collection. Cyclones have been operated at temperatures as high as 1000°C and pressures as high as 500 atm. In more detail, the gas-solid mixture enters in a rotating motion and the vortex formed develops centrifugal force which throws the particles radially outward before they fall downward. The gas on the other hand flows downward until it nears the bottom then it spirals upward in a smaller spiral resulting in a double vortex. In general, the more solids present in the inlet gas stream, the higher the efficiency. Efficiency is also generally increased with increasing inlet gas flow rate. The centrifugal force in a cyclone ranges from about 5 times gravity in large, low velocity units to 2500 times gravity in small, high-resistance units. They are generally applicable in removing particles over $5\ \mu\text{m}$ in diameter from gases and specifically useful in the first stage of physical separations for this project.

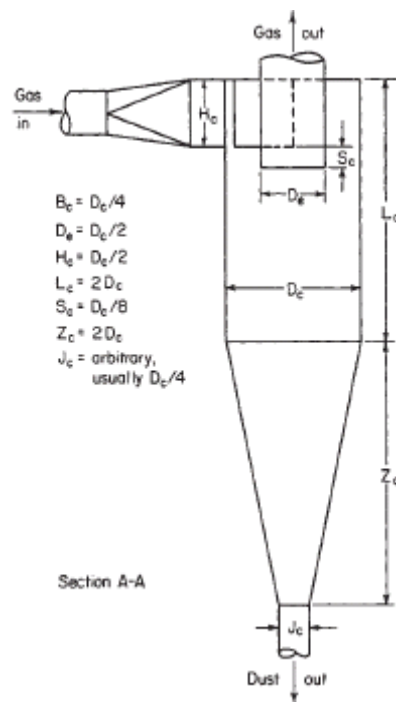

Figure 2: Cyclone Separator and dimensional ratios

It is assumed that particles on entering a cyclone quickly reach their terminal settling velocity.

Factors that increase collection efficiency



1. Reducing the gas outlet pipe diameter. However, this will also increase the pressure drop. If the gas outlet pipe diameter is reduced, the outlet vortex must also be increased to compensate.
2. Reducing the diameter of the unit: A smaller diameter unit operating at a fixed pressure drop gives a higher efficiency. Small diameter cyclones, however, will require a multiple of units in parallel for a specified capacity.

The final design involves a compromise between collection efficiency and complexity of equipment. It is customary to design a single cyclone for a given capacity, resorting to multiple parallel units only if the predicted collection efficiency is inadequate for a single unit.

Advantages of a cyclone separator

1. More effective than a gravity settling chamber because the outward force on the particles in many times the force of gravity.

Disadvantages of a cyclone separator

1. Unless very small units are used, efficiency is low for collection of particles smaller than $5 \mu\text{m}$.

5.2.4 Baghouse Filter

Bag house filters are collectors in which dust is removed from the gas stream by passing the solids-laden gas through a fabric made of woven cloth or felt. The pores in the medium (particularly in woven cloth) are usually many times the size of the dust particles, so that collection efficiency is low until sufficient particles have been collected to build up a “precoat” in the fabric pores. Once the dust layer has been fully established penetration is usually extremely low. Only limited additional means remain for influencing collection efficiency by filter design. Filter design is related mainly to choices of gas filtration velocities, pressure drops and fabric-cleaning cycles.

Because of their inherently high efficiency on dusts in all particle size ranges, fabric filters have been used for collection of fine dusts and fumes for over 100 years. The greatest limitation on



filter application has been imposed by the temperature limits of available fabric materials. The upper limit for fabrics made from glass and synthetic fibers is 260°C (500°F).

The cost of the filter bags represents a substantial part of the erected cost of a bag filter—typically 5 to 20 percent, depending on the bag material². The cost of bag repair and replacement is the largest component of the cost of bag-filter maintenance. Consequently, the proper choice of filter fabric is critical to both the technical performance and the economics of operating a filter.

In filter operation, it is essential that the gas be kept above its dew point to avoid water-vapor condensation on the bags and consequently, plugging of the bag pores. However, fabric filters have been used successfully in steam atmospheres, such as those encountered in vacuum dryers.

Efficiency of the baghouse filters

The inherent collection efficiency of fabric filters is usually so high that, for practical purposes, the precise level has not commonly been the subject of much concern. Furthermore, for collection of a given dust, the efficiency is usually fixed by the choices of filter fabric, filtration velocity, method of cleaning, and cleaning cycle, leaving few if any controllable variables by which efficiency can be further influenced. Inefficiency usually results from bags that are poorly installed, torn, or stretched from excessive dust loading and pressure drop.

5.2.5 Adsorption

Activated carbon is selected for the adsorption process because it is hydrophobic while silica gel is hydrophilic. Since the feed to the adsorber is PCB and water and we wish to isolate the PCB alone, we choose the absorber that does not absorb water as well. Activated carbon does not absorb water.

We will now discuss the preliminary data acquisition to complete the HYSYS simulation for the soil remediation process. The state of the art remediation technology for remediating contaminated soils with poly-chlorinated benzenes and other pollutants will be the thermal

² Reigel and Bundy, *Power*, **121**(1), 68 (1977)



desorption process. This process will incorporate the following equipment: compressed air tank, blower, furnace, fluidized bed, cyclone, bag house, absorber column, and condenser and then recycle. The flow diagram for the thermal desorption process is as follows:

The assumption made for this separation process is that the fluidized bed is based on 99% efficiency. Then the temperature was calculated to 350°C, the pressure to be 405.3 kPa, and the molar flow to be 89.50 kgmol/hr, data is from the exiting fluidized bed. The compositions exiting the fluidized bed were calculated to be the following:

Components	Mole Fraction	Vapor Mole Fraction	Solid Mole Fraction
CO ₂	0.0500	0.0510	0.0000
O ₂	0.0400	0.0408	0.0000
H ₂ O	0.0400	0.0408	0.0000
N ₂	0.8500	0.8662	0.0000
PCB	0.0013	0.0013	0.0000
SAND	0.0187	0.0000	1.0000

Table 3: Mole Fractions of components of Fluidized Bed Effluent

The components for PCB and sand had to be made under hypothetical components in HYSYS since it was not listed in the component list. This was done by entering their physical properties from Chemical Properties Handbook, Yaws, C.L.1999 McGraw Hill. In the hypothetical component for sand the log probability was chosen to give a range of particle size distribution for the separation process as follows:

Particle Size (mm)	Mass In Range (%)
0.1116	0.01
0.1490	0.04
0.1988	0.15
0.2654	0.48



0.3542	1.32
0.4727	3.02
0.6309	5.88
0.8421	9.68
1.124	13.49
1.500	15.93
2.002	15.93
2.672	13.49
3.566	9.68
4.760	5.88
6.353	3.02
8.479	1.32
11.32	0.48
15.10	0.15
20.16	0.04
26.91	0.01
35.91	0.00
47.93	0.00

Table 4: Particle Size Distribution & Mass Percent

Minimum particle diameter was set at 4.695E-2 mm and the parameters for the cyclone were of the following:

- High efficiency configuration
- Lapple efficiency method
- Particle diameter: 4.077E06 mm
- Particle efficiency: 90.00 %
- Particle density: 2000 kg/m³

The conditions of the cyclone were of the following:



Name	Cyclone Inlet	Cyclone Solid	Cyclone vapor
Vapour	0.9813	0.000	0.9981
Temperature (°C)	350.0	350.0	350.0
Pressure (kPa)	405.3	405.3	405.3
Molar Flow (kgmole/hr)	89.4985	1.5063	87.9922
Mass Flow (kg/hr)	2625.4196	90.3920	2535.0275
Std Ideal liq Vol Flow (m ³ /hr)	3.1144	0.0502	3.0642
Molar Enthalpy(kJ/kgmole)	-1.831E4	8.155E04	-2.002E04
Molar Entropy (kJ/kgmole °C)	192.2	1615	167.9
Heat Flow (kJ/hr)	-1.6387E06	1.2284E06	-1.7615E06

Table 5: Cyclone Conditions

Sizing the cyclone:

Inlet Width Ratio	0.2000
Inlet Height Ratio	0.5000
Cyclone Height Ratio	1.500
Gas Outlet Length Ratio	0.5000
Gas Outlet Diameter Ratio	0.5000
Solid Outlet Diameter Ratio	0.3750
Body Diameter	4.803 m
Total Height Ratio	4.000

Table 6: Sizing for the Cyclone



The overall performance for the cyclone was that three parallel cyclones were needed for the separation process, the pressure drop in the cyclone was 7.579E-06 kPa, and the overall efficiency was 90.00%. These results were based on the particle size distribution given earlier in the separation process requirements. The cyclone size and handling constraints were of the following:

- Maximum diameter: 5.000 m
- Minimum diameter: 0.3000 m
- Maximum pressure drop: 15.00 kPa
- Maximum number of cyclones: 20

The cyclone vapor effluent then enters the bag house for further filtration of solid fines since it is not 100% and the cyclone solid effluent is disposed.

The cyclone vapor effluent then proceeds to the bag house for further filtration of solid fines. There is no need to input any information since the bag house does the calculations. The physical parameters and the sizing for the baghouse were given to be:

Max gas velocity	5.0E-03 m/s
Bag filter area	1.480 m ²
Clean bag pressure drop	0.2400 kPa
Dirty bag pressure drop	2.000 kPa
Bag diameter	0.30 m
Bags per cell	78
Bag spacing	0.02 m

Table 7: Physical Parameters and Sizing for the Baghouse

The conditions of the baghouse were of the following:

Name	Cyclone Vapor	Vapor Effluent Bag	Solid Effluent Bag House
------	---------------	--------------------	--------------------------



		House	
Vapour	0.9981	1.000	0.0000
Temperature (°C)	350.0	350.0	350.0
Pressure (kPa)	405.3	405.3	405.3
Molar Flow (kgmole/hr)	87.9922	87.8249	0.1673
Mass Flow (kg/hr)	2535.0275	2524.9855	10.0420
Std Ideal liq Vol Flow (m ³ /hr)	3.0642	3.0586	0.0056
Molar Enthalpy(kJ/kgmole)	-2.002E04	-2.021E04	8.155E04
Molar Entropy (kJ/kgmole °C)	167.9	165.1	1615
Heat Flow (kJ/hr)	-1.7615E06	-1.7752E06	1.3647E04

Table 8: Bag House Conditions

The filtration results for the baghouse were as follows:

- Filtration Time: 3.6 hours
- Number of cells: 1
- Area/Cell: 14.19 m²
- Particle Diameter: 4.077E06 mm

There was no need for the venturi scrubber after the bag house since there were negligible solid fines after the baghouse. The next step was the gas adsorption system, the condenser, and the recycle stream back to the fluidized bed.

The gas adsorption system's primary use is to remove low concentration gases and vapors from a exhaust stream by having the material adhering to a surface of porous solids. The adsorbents used in a gas adsorption system are activated carbon, alumina, bauxite, and silica gel. All of



these adsorbents are hydrophilic except for the activated carbon; we wanted the poly chlorinated benzenes to attach to the adsorbent and not the water. Therefore activated carbon was chosen to be the adsorbent. A typical fixed bed carbon system; an air vapor mixture enters a blower and then passes through a cooler. The cooling is for the poly chlorinated benzenes can be adsorbed per unit mass of carbon increases as temperature decreases. The cool gas stream enters the adsorbent bed where vapor is removed and the remaining gases enter the condenser.

The volume of the adsorption system was calculated by the following:

The fixed bed is packed with particles of a porous adsorbent material and the interparticle void fraction is 0.40. The intraparticle porosity is 0.50, with two-thirds of this in cylindrical pores of diameter 1.4 nm, the rest in much larger pores and 13.5 percent of the total packed-bed volume.

$$V = \Pi * r^2 * h = \Pi * 1.5 \text{ ft} * 8 \text{ ft}$$
$$V = 56.55 \text{ ft}^3$$

The volume of the absorber material was calculated as:

$$V = 2/3 * 56.55 \text{ ft}^3$$
$$V = 37.70 \text{ ft}^3$$

Pore Volume:

$$\text{Pore Volume} = (0.6) * (37.70 \text{ ft}^3)$$

$$\text{Pore Volume} = 22.62 \text{ ft}^3$$

$$\text{Surface area} = (37.40 \text{ ft}^2) * (0.4)$$

$$\text{Surface area} = 14.96 \text{ ft}^2$$

The solute in the cylinder:



$$\text{Solute in the cylinder} = \text{Volume of adsorption system} \times 13.5\% = (56.55 \text{ ft}^3) \times (0.135)$$

$$\text{Solute in the cylinder} = 7.6 \text{ ft}^3$$

5.2.6 Condenser

Temperature 350 °C

Constant Pressure 403.3 kPa

Temperature 79.192 C

Vapor Streams:

CO2 445.02 kg/ hr

O2 445.02 kg/ hr

H2O 44.52 kg/ hr

N2 667.61 kg/ hr

Recycled to Furnace

Overall ndot = **1780.47** kg/ hr

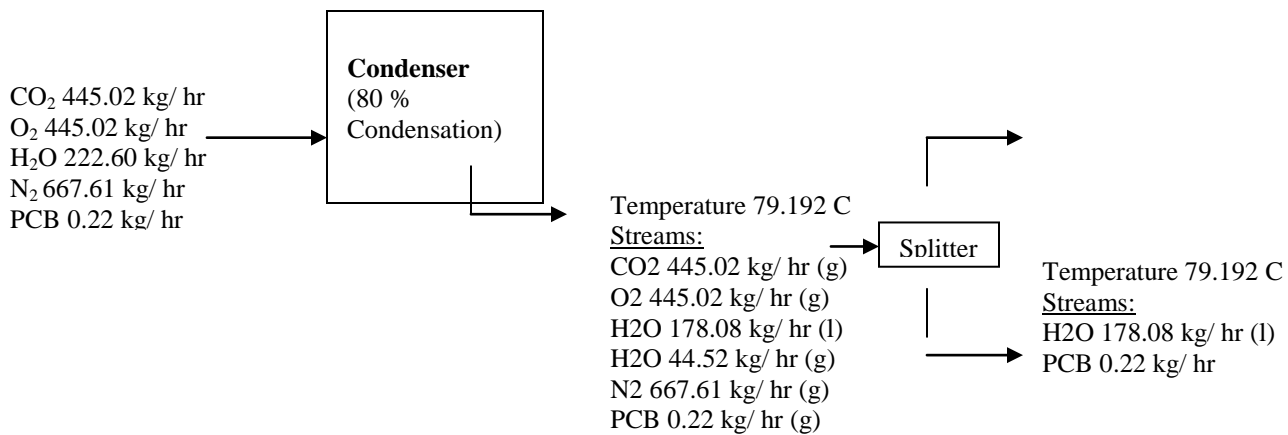

*Duty of condenser is set based on the boiling points of H₂O and EG coming into the system.

*Where EG = effluent gas

Compounds	Vapor Eff. Fraction	Mole Rate [kg/ hr]	Mole Rate into Condenser [kg/ hr]
CO ₂	0.2469	1802.41	445.02
O ₂	0.2469		445.02
H ₂ O	0.1235		222.60
N ₂	0.3704		667.61
PCB (0.1%)	0.0123		0.22



to Cond.)			
SAND	0		
Total			1780.47

Energy balance for the condenser:

$$V_1 H_V + Q_C = (L_o + D)h_D \quad (5)$$

$Q = H = (\text{out}) n_i H_i - (\text{in}) n_i H_i = \text{heat removed from condenser}$

*Condenser changes the phase of the entering vapor stream – the splitter will change the flow rates.

* Assume negligible heat transfer between system and surroundings

5.3 Cost Analysis

Capital Cost Monthly

Based on the size and dimensions of our equipments we estimated the cost of process plant.

Equipment	Unit Cost	Number required	Total cost including Installation (\$)
Blower	3600	1	10,800
Furnace	60,285	1	180,885
Fluidized bed	17,000	1	51,000
Compressor	55,300	1	165,900
Cyclone	10,400	2	62,800
Baghouse	12,100	1	363,100
Carbon Adsorber	291,260	1	873,780
Condenser	1,100	1	3,300
TOTAL			\$1,711,565



Capital Cost Comparison

Capital Cost Analysis

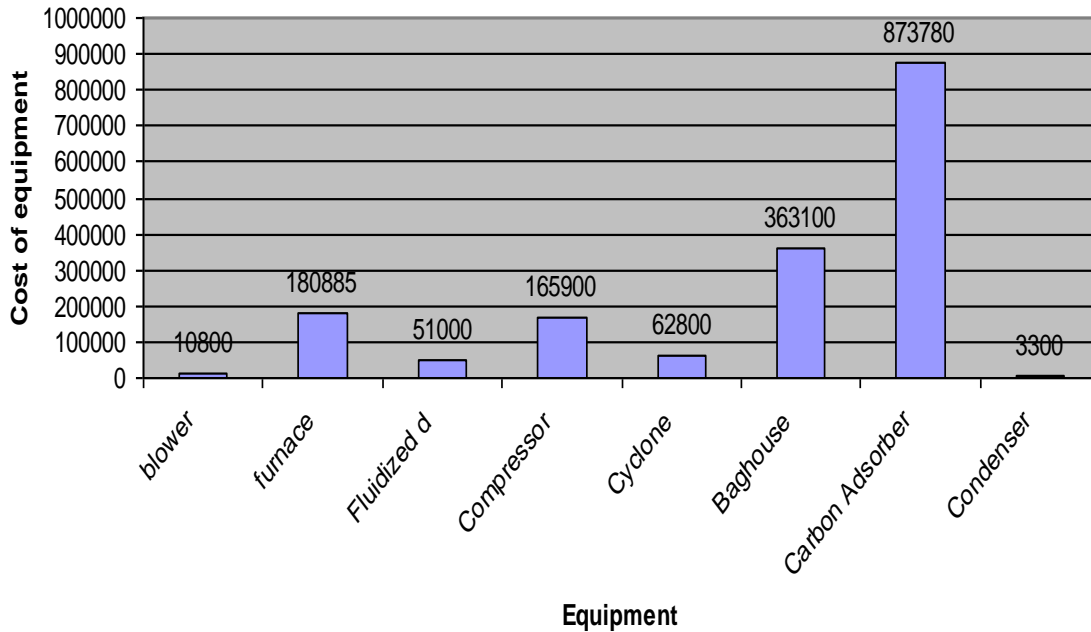

Fixed, Variable and Capital Cost

Fixed costs are un-expired assets or *expenses* whose total does not change in proportion to the activity of a business, within the relevant time period or scale of production. Fixed costs include, but are not limited to, overheads (rent, insurance, and such) and can include direct costs such as payroll (particularly salaries). Capital assets will generally be considered part of fixed costs, but treated differently.

Variable cost is a cost of labor, material or overhead that changes according to the change in the volume of production units. Combined with fixed costs, variable costs make up the total cost of production. While the total variable cost changes with increased production, the total fixed cost stays the same.

Capital cost is the cost associated with initial construction of the plant and the modifications. These end up as embedded costs.

Project Fixed Cost



Waste Water Treatment (lb/yr)	\$250,000
Landfill (sand) (lb/yr)	\$ 0
Unit Cost (bed truck)	\$50,450
2 flat bed trucks	\$100,900

Purchased Components

Methane	\$2.12/lb
Air	\$.06/lb
Carbon	\$2.06/lb
Electricity	\$0.06/Kwh

Component	Power (KW)	Utility Cost(\$)/hr
Splitter	44Kw	2.64
Cooler	223Kw	13.38
Cyclone	200kw	12
Baghouse	208KW	12.84

Total Annual Treatment Cost

Capital Cost/yr	\$20,538,780
Fixed Cost	\$27,360,515
Variable Cost	\$2,582,045
Annual Cost	\$50,481,340

Advantages of cost Analyses:



- Cost analyses can provide estimates of what a program's costs and benefits are likely to be, before it is implemented.
- Cost analyses may improve understanding of program operation, and tell what levels of intervention are most cost-effective.
- Cost analyses may reveal unexpected costs.

Disadvantages of Cost Analyses:

- Whether or not the program is having a significant net effect on the desired outcomes.
- Whether the least expensive alternative is always the best alternative.

5.4 Safety and Hazard analysis

Hazard Analysis

The principal unique hazards associated with high-temperature thermal desorption include:

1. Physical hazards
2. Chemical hazards
3. Radiological hazards
4. Biological hazards

1. Physical Hazards

Desorption treatment units may expose workers to elevated noise levels in the work area due to the operation of the air blower, pumps, and the ignition of fuels within the furnace. Regulatory requirements should be followed to address noise. These include:

- a. Wearing personal protective equipment (PPE) for hearing protection.
- b. Using personal electronic communications devices, such as a dual ear headset, to overcome ambient noise.
- c. Noise-free areas should be established during operations to provide breaks from the noise, which can cause fatigue and inattention.



Thermal desorption usually requires storage of flammable or combustible fuels. Hazards associated with flammable/combustible fuels include the potential for on-site spills or release of material. The release may cause worker exposure to the vapors generated or a fire hazard may exist if the material is ignited. To control fire hazards, consideration should be given to ensure that the type of tanks used are appropriate, equipped with pressure-relief devices, and are bermed to help prevent release of material to the work environment. The area should also be adequately ventilated to help prevent the accumulation of flammable vapors. Only trained and experienced workers should be permitted to work on the system.

Also during excavation, saturated soils may be ignited by sparks generated when the blade of the dozer or crawler contacts rocks or other objects. The periodic application of water to the soils may help to control soils from being ignited. The soil handling equipment may also be equipped with non-sparking buckets or blades. Transfer systems such as the conveyors used to transport sand to the fluidized bed expose workers to injury if limbs or clothing are caught in the system. As a control, emergency shutoff controls should be installed in multiple locations. Lock-out/tag-out procedures should also be rigorously enforced.

The thermal desorption process uses high temperatures to heat materials. The materials that are processed will exit the system hot, exposing workers to possible thermal burns hazards. Heat resistant gloves may be used to help prevent thermal burns. As a warning of the potential hazard:

- a. Safety control systems should be included to protect people and equipment.
- b. Signs should be posted warning of high temperatures.
- c. Safety barriers can be included to isolate critical sections of the equipment.
- d. Heat resistant gloves may be used to help prevent thermal burns.

Depending on soil type, exposure to respirable quartz may be a hazard. Worker exposure to dust rich in respirable quartz may be minimized by periodically wetting the soil with water. Workers may also be exposed to infrared radiation hazards associated with working in the vicinity of thermal desorbing treatment units. The exposure, depending on the temperature of the equipment, length of exposure, and other variables, may increase the risk of cataracts.



Control: Workers should minimize their exposure to heated equipment surfaces. If prolonged work is required, eye protection using the appropriate shade safety glass may help to control exposure to the eyes.

2. Chemical Hazards

During operation of the desorption unit, workers may be exposed to byproducts of incomplete combustion such as carbon monoxide, or to airborne toxic materials. To control this, wastes should be classified prior to desorption, and only those waste materials compatible with the process should be fed into the unit. When such materials are known or suspected in the waste byproducts, the design of the process and off-gas treatment should control their generation and release. If control is not possible with the design, the personnel should operate with the appropriate PPE (e.g. an air-purifying respirator equipped with filters/cartridges appropriate for the contaminants of concern) and air emissions controls.

3. Radiological Hazards

Description: Not Applicable to this project

4. Biological Hazards

Description: Not Applicable to this project

5.5 Definitions and units of select parameters and variables

$\rho_{flue\ gas}$, g/cm ³	Density of the flue gas stream to the fluidized bed
ρ_p , g/cm ³	Particulate density of soil
D_p , m	Particulate diameter of soil

5.6 Physical properties of soil

Thermal conductivity, W/m.K = 0.52

Thermal diffusivity, m²/s = 0.14x10⁻⁶



5.7 Work to be done going forward

1. Calculate theoretical value for particle size removed by the cyclone using the equation relating cyclone size, velocity, viscosity and density of particles. This equation can be found in Perry's handbook under solid-gas separations and will give a more accurate estimation for the mass of soil going out through the top of the fluidized bed.
2. Calculate the bed height and maximum pressure drop. To calculate the maximum pressure drop, which occurs at fluidization, we use the Ergun's equation.

$$\Delta P = L \times \left[\left(150 \mu \frac{\varepsilon V}{D_p^2} \cdot \frac{(1-\varepsilon)^2}{\varepsilon^3} \right) + \left(\frac{1.75 \cdot \rho_p \cdot \varepsilon^2 V^2}{D_p} \cdot \frac{(1-\varepsilon)}{\varepsilon^3} \right) \right]$$

Where ε is the void fraction in the bed and V is the flue gas velocity.

3. Establish a fabric cleaning cycle in the baghouse
4. Applications for the soil after treatment.

6. RECOMMENDATIONS

Throughout this term our IPRO class gained experience in the analysis and design of the fluidized bed process for soil remediation. One of the first and most important aspects of the learning and preparation process is research. Research should be done early and thoroughly, possibly in the first two to three weeks of the term. Doing extensive research is very important in realizing what has already been done by other people, what alternatives there are and how to take advantage of the work that other people have done without misusing the information found. But for research to be effective it is of utmost importance to divide the work between team members based on research areas and topics and according to each individual's field of expertise. Also to save time and money, effort should be placed into getting information direct from the industry or government agencies. While the internet can point you in the right direction it should be realized that not all of the information from this source is reliable therefore it should be left as one of the last choices.



The creation of sub-teams proved to be a very effective way of meeting goals and tasks requested by the project plan. The design sub-team was responsible to use the research information gathered to develop the process design. The work within the design sub-team was divided further to cover all areas of possibilities for the design process. This division allowed for the involvement of all team members as well as for the exploration of several opportunities for the process. The organization sub-team was responsible to make sure the team met all goals described in the objectives as well as all deliverable deadlines. Within the organization team the work was divided evenly among the members while letting each person work on tasks that best fitted their character and background.

Additional team meetings were another good way of building team spirit while working on the project at the same time. These meetings helped form stronger bonds between the members which allowed for more effective communication and therefore better results throughout the project. Communication between team members was also strongly encouraged to allow for the resolution all possible conflicts before they became a detriment to the project.

7. REFERENCES

1. Leeder, M.R., *Sedimentology*. Harper Collins Academic, London, 1982, p. 36.
2. Perry's Handbook for Chemical Engineers
3. Transport processes and Separation Process Principles, 4th Edition, Geankoplis
4. Billings and Wilder, *Handbook of Fabric Filter Technology*, vol. I, EPA No. APTD-0690, NTIS No. PB-200648, 1979
5. Practical Process Engineering by Henry J. Sandler. Edward T.Luckiewicz
6. Product and Process Design Principles: Synthesis, Analysis, and Evaluation by Warren D. Seider, J. D. Seader, and Daniel R. Lewin (New edition)
7. Chemical Properties Handbook, Yaws, C.L.1999 McGraw Hill

8. ACKNOWLEDGEMENTS

Dr. Pagilla

Professor of Environmental Engineering, Illinois Institute of Technology



November 1st, 2006

Items discussed: Gave direction with the design of our project. Dr. Pagilla has expertise in the design of treatment plants. He is researching soil contaminated by organics and metals in his laboratory.

Dr. Aderangi

Professor of Chemical Engineering, Illinois Institute of Technology

November 7th, 2006

Items discussed: Dr. Aderangi helped with determining the minimum fluidizing velocity in the fluidizing bed. He supplied our group with a lab manual containing pertinent equations for the design of the fluidized bed.

Dr. Lindahl

Professor of Chemical Engineering, Illinois Institute of Technology

Throughout Semester

Items discussed: Dr. Lindahl provided insight throughout the semester. One specific instance of his guidance was in helping determine the optimum temperature of the fluid gas and water recycling streams.

Raymond Losch

Master's Degree Candidate, Illinois Institute of Technology

Throughout Semester

Items discussed: Ray initiated a HYSYS tutorial that allowed the group to model the design process using HYSYS simulation software.

David Graham

Environmental Coordinator

Department of Environment- Urban Management and

Brownfields Redevelopment

November, 2006



Items discussed: David answered questions related to regulations for hazardous waste cleanup, as well as if there were any public reports about contaminated sites. He gave case studies to consider through the USEPA, in addition to the website www.frtr.gov.

Dr. Abassian

Professor of Chemical Engineering, Illinois Institute of Technology

Throughout Semester

Items discussed: Dr. Abbasian was the Coordinator of I PRO 345 and gave guidance through the semester. He also gave a useful critique of our presentation.