

ILLINOIS INSTITUTE OF TECHNOLOGY

LOW-COST WATER PURIFICATION SYSTEM DESIGN & ANALYSIS FOR
APPLICATIONS IN MEXICO AND THE US
IPRO 355

March 8, 2006

MIDTERM PROGRESS REPORT
DESIGN TEAM

TABLE OF CONTENTS

Summary	2
Design	3
Composition	12
Bacteria Testing	15
Appendix	16
Previous Designs	17
New Designs	19
Lab Records	27
Kiln Records	29
Mixture Results	30
Bacteria Procedure	31

SUMMARY

Klaraqua, is a low cost water purification system developed to promote health and economics in developing countries and other areas in need of clean and safe drinking water.

The design team of Klaraqua recently adopted a new design to minimize leakage in the filtration device. The new design utilizes a cone-like insert that will direct the filtered water from the first bowl shaped filter to the center of the second filter. The second filter will still be shaped like a disc. However, the top will be slightly concave in order to minimize leakage due to water flowing over the sides of the filter. A second cone-like insert will be used at the site of the second filter in order to direct the water to the center of the third filter. In addition, the cast has been slightly modified. 90° angles have been replaced with slightly obtuse angles in order to prevent pools of water forming in the corners of the cast.

The composition team is currently in the process of evaluating different compositions for the filter. During this process, several conclusions have been made. One, the weight of the sawdust is directly related to the particle size. Two, the flow rate, which is directly related to the amount of sawdust used in the mixture, is also directly related to the fragility of the disk. Thus, the greater the flow rate, the more fragile the disk is will be. Related to this, is the size of the sawdust. As the size of the sawdust particles increase in the mixture, the flow rate increases in proportion to it. However, the size of the sawdust also impacts the cohesion of the filter mixture.

The bacteria team recently performed some preliminary tests in order to tweak the procedure and begin evaluation of the filters. The team successfully revitalized the bacteria and started growth cultures. In addition, testing began on a small number of filters. Some errors were found in the brushing of the disks with colloidal silver; the team evaluated the problem and proposed some solutions. The next test will incorporate these measures. The team is currently awaiting results from the Fluroscopy Microscope in order to evaluate the efficiency of the disks in killing bacteria.

In the near future, prototypes will be made in order to evaluate their effectiveness. In addition, testing will continue among all three branches of the design team: design, composition, and bacteria.

Technical Chapter

Design and Characterization of the Cast and Filters

This chapter describes engineering criteria and test procedures involved with design and characterization of Klaraqua. Previous and alternate designs are present in the appendix.

1.1 Design Considerations

Klaraqua, is a low cost water purification system developed to promote health and economics in developing countries and other areas in need of clean and safe drinking water.

This system was therefore, designed considering the following factors:

- ☒ Use locally available material such as clay
- ☒ Design as simple as possible in order manufacture or produce it locally
- ☒ User friendly and safe for children and household application (no chemicals involved),
- ☒ Cost effective

1.2 Current Design

In order to avoid flooding the design was changed for a slope shape in the first step. Also we decide that the best approach is to have a packed bed between the first and second step, and another between the second and third step. With the packed bed the leakage is prevented at the edges.

The packing material is planned to be activated carbon for removing odor and taste and organic modified clay to remove nitrates.

An alternative to the above design is to utilize cones instead of the packed bed. The cone would be placed between the first and second filters. The cone would direct water from the first filter to the center of the next filter. This would reduce the likelihood of water flowing past the filter by going over its edge.

Advantages

- ☞ There is the possibility to address different contaminants due the versatility of 3 layers.
- ☞ Light in weight
- ☞ Leakage is prevented in all stages
- ☞ Collection of water in a separate entity

Disadvantages

- ☞ Increase in cost and maintenance for the filter

This plastic cast is the one that we are constructing right now. The cast was divided in 3 pieces (A, B and C) for easy assembly.

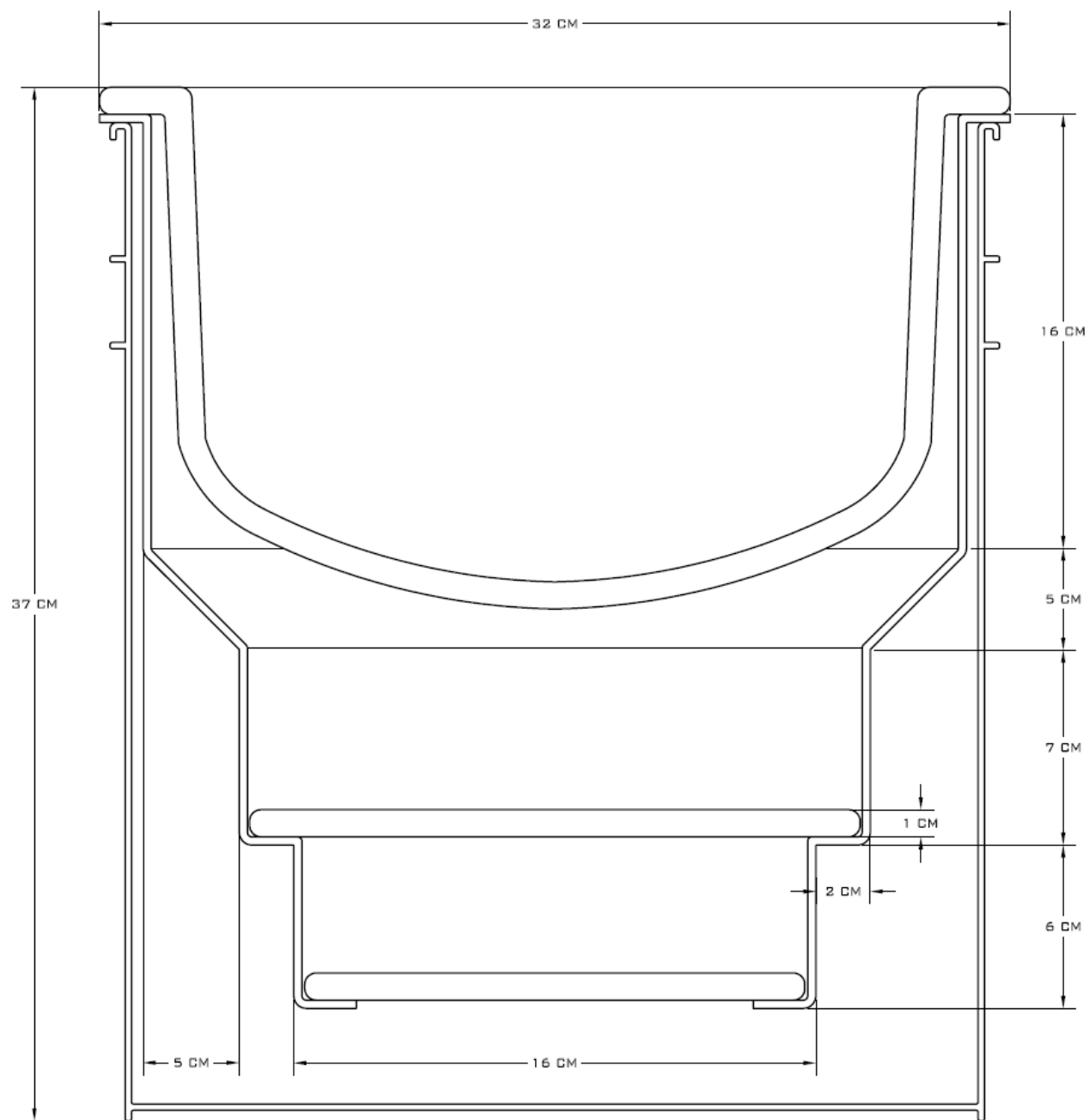

Figure D3.1 Filter structure [D.3.A.1]

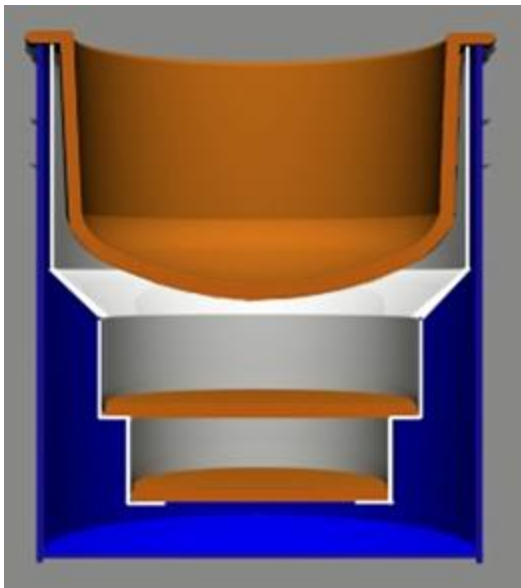

Figure D3.2 Filter Section [D.3.A.2]

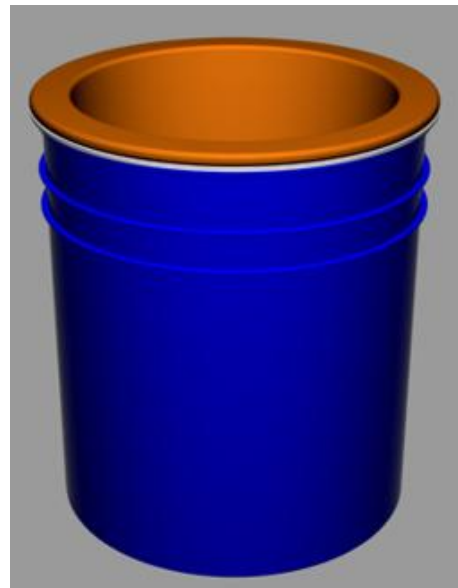
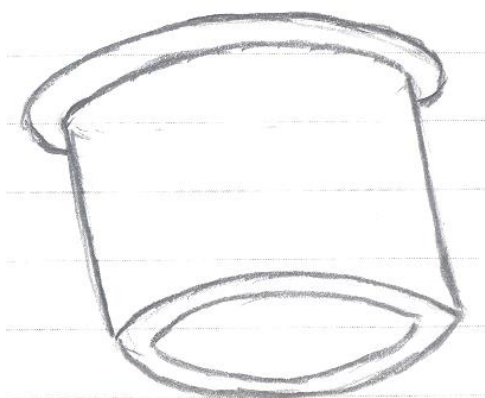
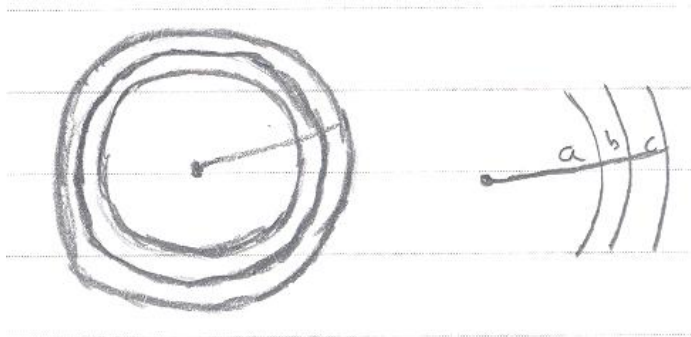

Figure D3.3 Filter Perspective [D.3.A.3]



Perspective view



Top view

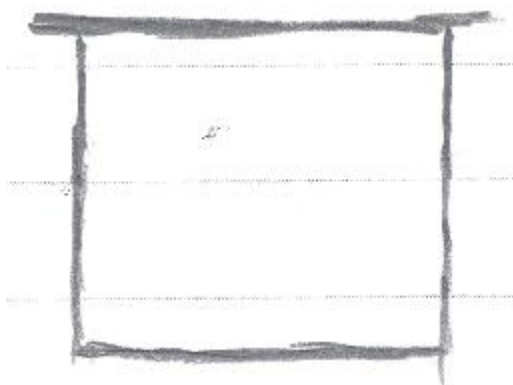

Lateral view

Figure D3.4 Piece A [D.3.C.1]

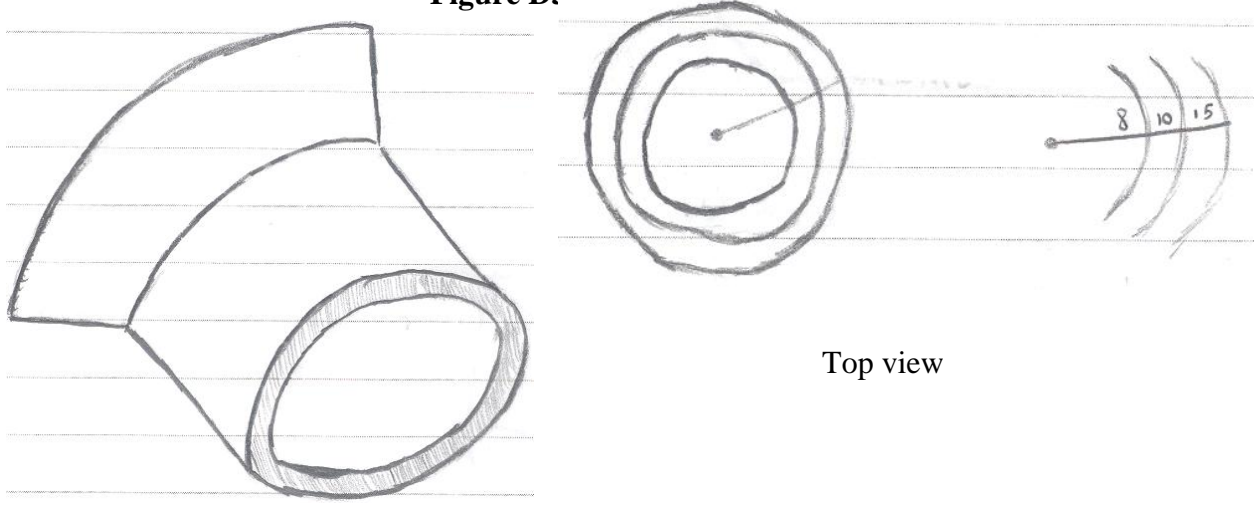

Top view

Perspective view

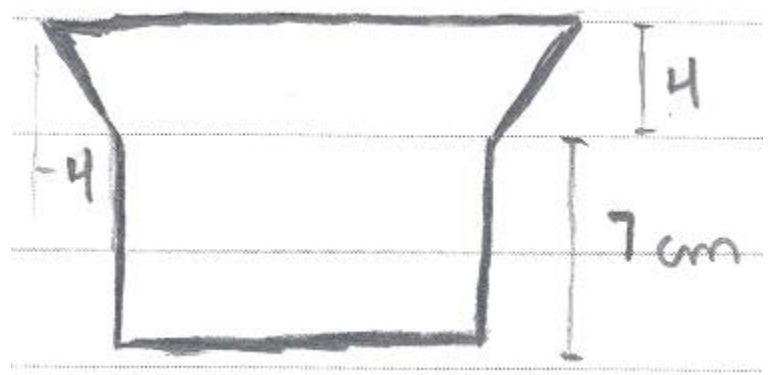

Lateral view

Figure D3.5 Piece B [D.3.C.1]

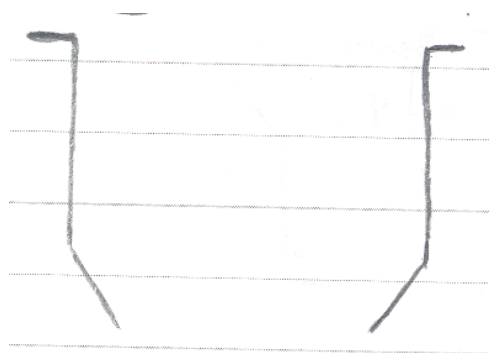

Lateral View

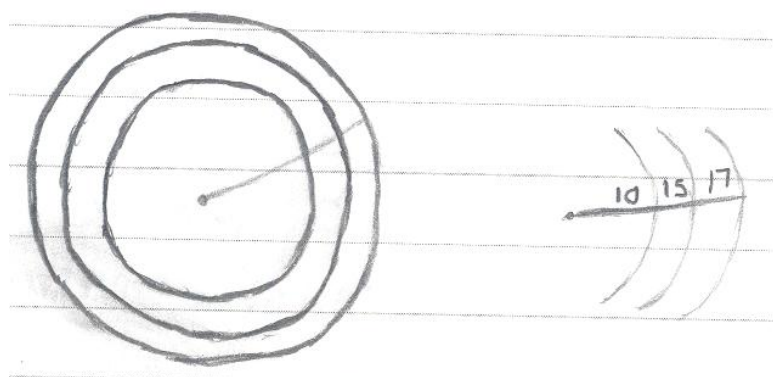

Top view

Perspective view

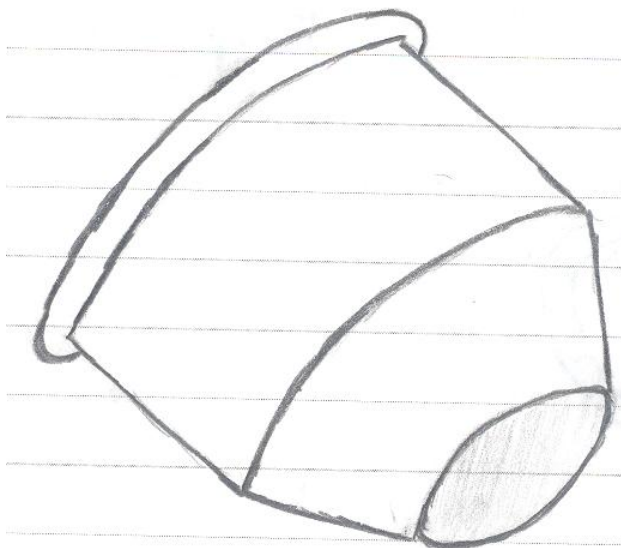

Figure D3.6 Piece C [D.3.D.1]

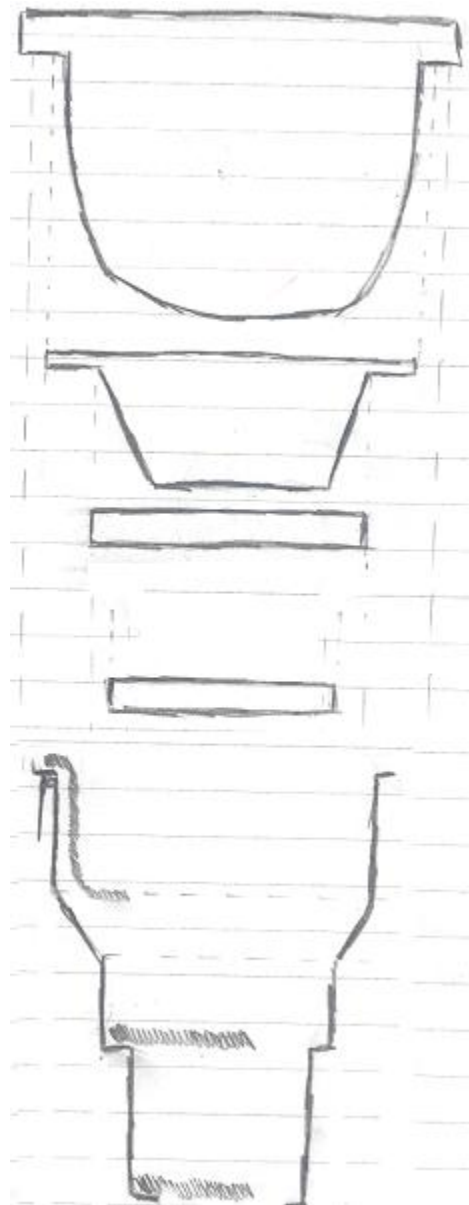

Figure D3.7 Filter Structure [D.6.A.1]

1.3 Plastic casting

In order to reduce cost of construction for the prototype, the manufacture of the plastic cast is being done. The ideal method of construction will be plastic injection, this is because we have 90° angles on the shape and the layers (A, B and C) are considerable separated. But as IIT do not have plastic injection, so we are using plastic vacuum.

Plastic vacuum have some disadvantages compared with the injection, we need negative pressure and we start from a flat plastic layer instead from a liquid plastic phase. The main problem starting from a flat layer is that when the vacuum is applies and 90° angles exist, there is a very short distance (X) that will became a 3D shape with high deep.

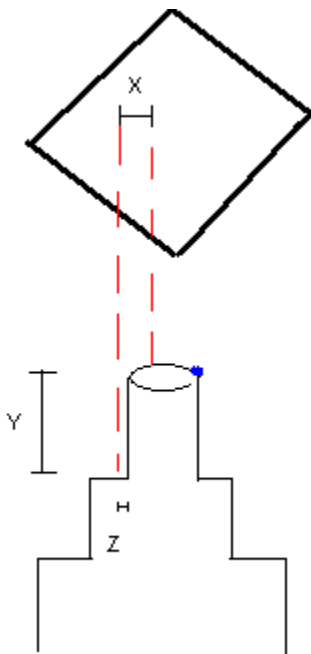

Figure 1. From flat to 3D

In figure 1 is possible to see the deformation that the flat layer will have when the vacuum is applied. The main problem is when a 1D distance (X) becomes a 3D volume (X+Y+Z).

The stress that the film needs to resist is high due the expansion asked in the cast. The existence of 90° angles in the cast enhances the problem.

Using as origin the top part of the cast (blue point), as showed in figure 1, we see that the angle that the section has is 270° regarding the height of the piece and the top of it. In order to have the most advantageous use of material is needed a greater angle (closer to 360° , a flat surface).

The physical restriction that we have on the angle is the real size, we can not exceed the 34 centimeters long and 31 in diameter. As equal we need to consider that the top part is not really a point, is a surface with 16 cm in diameter.

When the calculations were being made for the better slopes regarding each step, we realize that IIT labs do not have the capacity to produce a complete cast. Because of this we are scaling the cast to half of the size. With this scale up we hope that the plastic stress diminish enough to be feasible.

1.3 Actual actions

The creation of the plastic cast in a scale of a half is being done in the laboratory of architecture. Already is available a small unit as prototype, the disk are being created in order to be able of having a complete test.

COMPOSITION

Technical Chapter Composition of the Filters

This chapter presents all the steps involved in the creation of the disks and the important aspects and characteristics found during the manufacturing of them. The chapter is divided into several subsections: the mixture, special considerations, molding and drying, and disk firing. Lab reports are available in the appendix.

2.1 The Mixture

The first part in the creation of the disks is to make a mixture of clay, sawdust and water. The steps involved in the creation of the mixture are summarized into 4 basic steps:

- 1. Select the ratio of clay and sawdust:** selection of the ratio determines the amount needed for each component - in this case, clay and sawdust.
- 2. Sieving of the sawdust:** the sawdust is sieved to have a homogenous composition, therefore allowing for the creation of disks with the same characteristics.
- 3. Mix the clay with the sawdust:** they are mixed until a homogenous mixture is obtained.
- 4. Add water to the mixture:** water is added in small amounts followed by mixing until the mixture sticks together.

2.2 Special Considerations

Some important considerations or findings regarding these 4 steps:

The ratio used in the Laboratory is a volume ratio using a standard container (tuna can). The conversion to a mass ratio was made by measuring the mass of each component in a separate container. It is important to note that the weight of the sawdust is a direct relationship to the particle size; for example, the weight of one volume unit of sawdust sieved with a tray that has a mesh size of 9 is not the same if the tray has a mesh size of 28.¹

The ratio is an important factor in flow rate and in the strength of the disks. We found that the ratio is proportional to the flow rate and to how fragile is. The

¹ For more information about the Laboratory Work please see Appendix.

greater amount of sawdust used, the greater the flow rate and the greater the fragility of the disk².

The particle size of the sawdust is an important factor with respect to the flow rate of the disk. After some testing of disks made with different particle sizes of sawdust, it was found that the size of the sawdust is proportional to the flow rate: the greater the size, the greater the flow rate. The particle size of the sawdust is also an important factor on how cohesive the mixture is after water is added. The mixture becomes less cohesive as the particle size increases.

After the evaluation of the ratio and particle size of the mixture, it is important to find the correct relationship between ratio and particle in order to obtain an appropriate flow rate without making the disk too fragile or making the mass of clay and sawdust too difficult to stick together during the mixture making process. In this part the bacteriological aspect is not included but the final decisions about ratio and particle size are primarily governed by the results of the bacteriological testing.

Analyzing step 3 is important because the clay used is a powder, which is really fine in comparison to the one used in Mexico. We believe that it is one of the reasons for the dusty composition of the filter obtained after firing.

In step 4, it is important to add a small amount of water followed by properly mixing it until a homogenous mixture is formed and the mass sticks together well. It is important to understand that water is the bonding agent for the clay and sawdust mixture. Therefore, it has to be properly accomplished by not adding too much or too little water, that is the reason why the addition of water has to be in small amounts.

2.3 Molding and Drying

Once the mixture is finished, the next step is to make the disks. In order to do this, molds are used to properly shape the clay mixture. Molds can be plastic containers. To put the clay in the molds, it is necessary to wrap the mixture (clay, sawdust and water) in PVC plastic. This prevents the mixture from sticking to the mold.

2.4 Disk Firing

The disks are fired using a Kiln available in the Alumni Hall Laboratory. The kiln has the feature to introduce specific programs for the firing process. This allows the firing process to be individualized and allows for a greater amount of flexibility in the process. The programs used to fire the disks were made to meet certain specifications³.

² See EXCEL table of mixture to see the ratios used and the particle size of the saw dust used.

³ To see the specific program used on the different disks see the EXCEL table of mixture to see the program used in each disk and then go to the Kiln programs to see the specifications of each program.

After some disks were fired, we noted that the time of firing is really important in order to reduce the dusty composition of the disks and to prevent any fractures. The kiln records are keep are available in the appendix.⁴

⁴ See Kiln records spreadsheet.

BACTERIA TESTING

Technical Chapter Bacteria Testing of the Filters

This chapter summarizes the procedure utilized for evaluating the efficiency of the filters with respect to their ability to kill bacteria. The chapter is divided into several sections: Preparation of the Bacteria and Filters, filter testing, results, and concerns. Additional data is present in the appendix.

3.1 Preparation of the Bacteria and Filters

Revitalizing the bacteria is a fairly straightforward process. A soy broth needs to be created and aerated. The bacteria are placed into the broth, which is then placed into an incubator. Within 24 hours, bacteria growth will have occurred. A sample of the bacteria broth is taken and centrifuged. The excess broth is removed and the bacteria isolated. The bacteria are then placed into DI water. This solution will then be used to test the efficiency of the bacteria.

The clay filters need to be brushed with colloidal silver. In addition to this, they need to be soaked in water. This is done to minimize the absorption of the test solution by the filters. It has also been discovered that the disks need to be thoroughly rinsed before and after brushing.

3.2 Filter Testing

The filters are placed in to funnels, which direct their flow into glass flasks. The bacteria solution is poured onto the filters. The filtrate is collected after the solution has flowed through and placed into small vials. These vials are then taken to a fluoroscopy microscope and treated with the BacLight solution. The BacLight solution allows for the fluoroscopy microscope to evaluate the ratio of live to dead bacteria in the sample.

3.3 Results

3.4 Concerns

It was noted during the experiment that the samples for two of the filters (non-control ones) contained clay particles in them. The controls did not. There is reason to believe that either one, the brushing of the colloidal silver onto the filters is abrasive and causes some particles to form. Or two, the particles may be related to the colloidal silver itself. Or three, some other mechanism causes this. In the future, we plan to apply brushing (with no colloidal silver) to the controls in order to evaluate if the brushing itself is the cause. In addition, the filters will also be rinsed after the colloidal silver has been brushed on and dried.

APPENDIX

APPENDIX – DESIGN

A. Previous Design

The initial design consisted of a plastic bucket containing a plastic cast designed to hold three clay disks, two reservoirs were assumed for holding water. Reservoir one has contaminated water and it creates hydraulic head (top reservoir), reservoir two collects and store treated water (bottom reservoir). The hydraulic head on top of the filter enhance filtration rate, it also allows the user to add large quantities of water versus small quantities to the device. (See figures PV)

Advantages.

- ☞ Different situations can be addressed through the use of three filters, specifically other containments besides bacteria can be dealt with.
- ☞ Filter is light weight.

Disadvantages

- ☞ Greater leakage
- ☞ Collection of water in the same container

It is important to notice that if there is not 100% removal of bacteria and the water is collected in the same reservoir, the already filtered water will serve as an incubation media for the bacteria growth. The bottom reservoir can not be easily fully emptied if there is a side valve in the bucket.

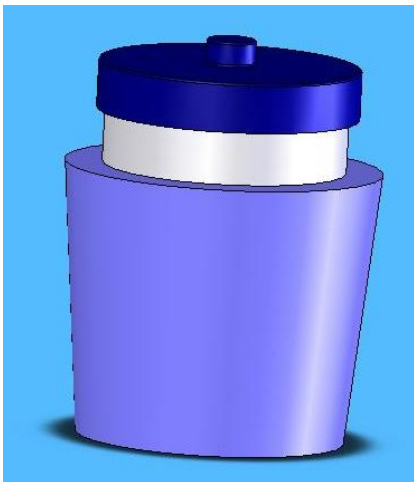

Figure PD.1 Assembled

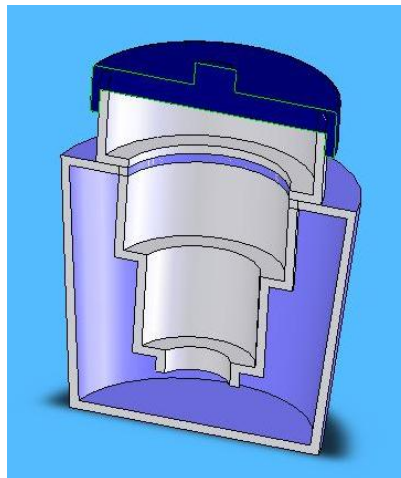

Figure PD.2 Section View

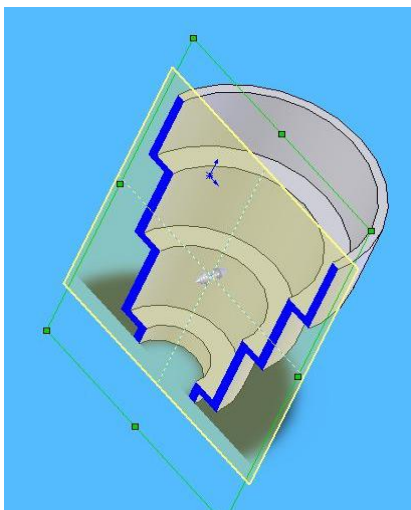

Figure PD.3 Section view

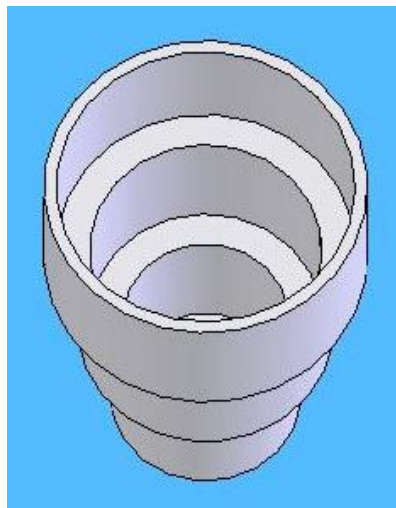

Figure PD.4 Furnace

NOTE: The nomenclature in the figures follows 3 patters. The name of the figure is related to the design to which it belongs, the description is related to the figure and the alphanumerical symbols after that is the name of the piece.

PD = Previous design

D1 = Design 1

Section view = Self explanatory

D.1.A.1 = name of the drawing or piece

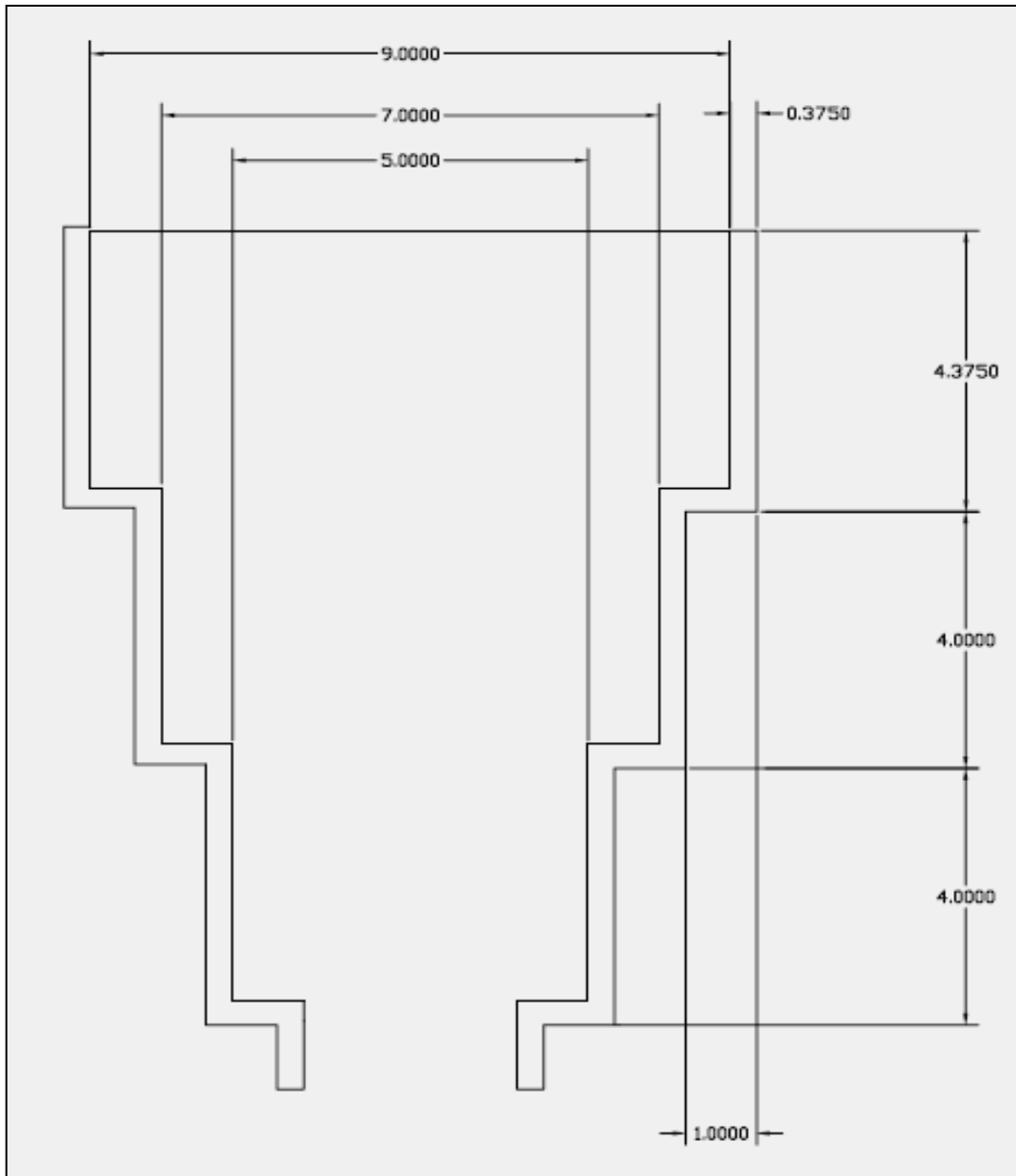

Figure PD.5 2D model

B. New designs

DESIGN 1

The design consists in the plastic bucket, the plastic cast and 2 plastic cones (D.1.A.2) that connect the disks 1-2 and 2-3. Also a plastic lid is placed over the first disk in order to prevent leakage (D.1.A.3).

Advantages

- ☞ There is the possibility to address different contaminants due the versatility of 3 layers.
- ☞ Light in weight
- ☞ Leakage is prevented in the second and third stages

Disadvantages

- ☞ Leakage in the first stage
- ☞ Impossibility of having a hydraulic head on the top
- ☞ Collection of water in the same container
- ☞ Complexity in the cones

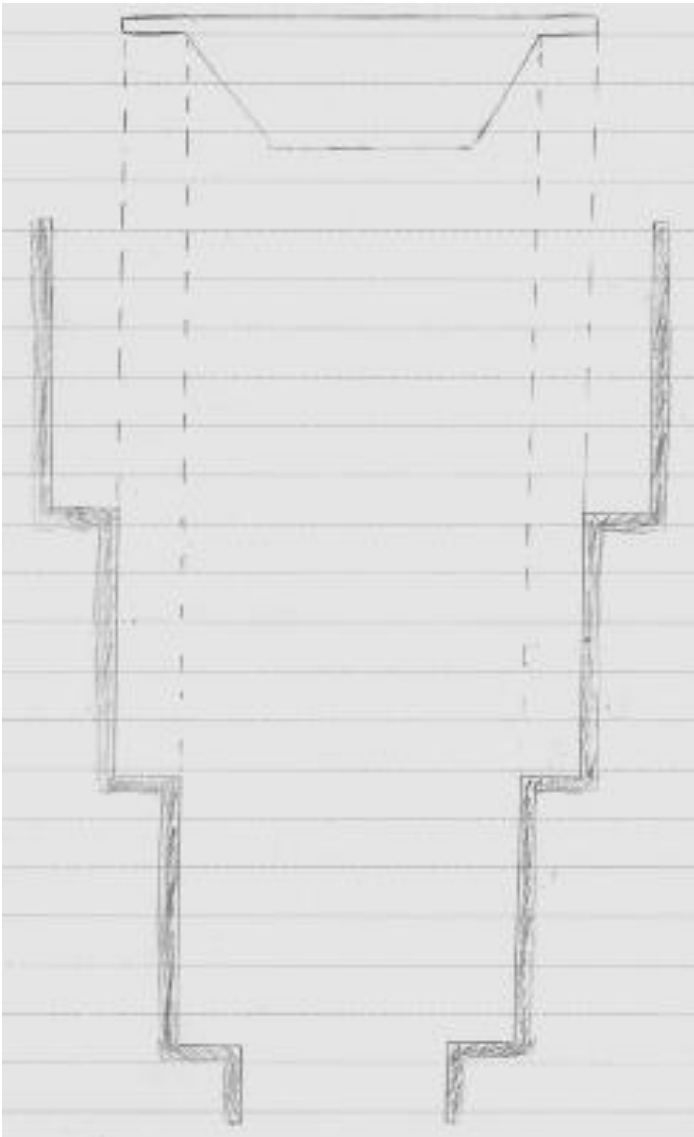
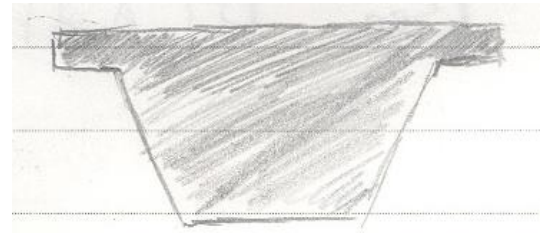

Figure D1.1 Filter structure
[D.1.A.1]



Perspective



Lateral view

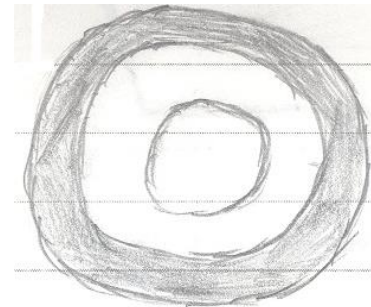

Top view

Figure D1.2 Cone shape [D.1.A.2]

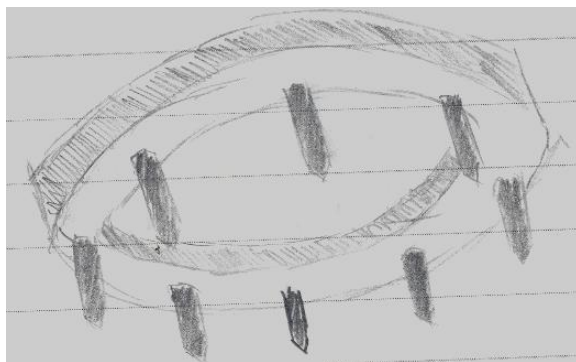

Perspective

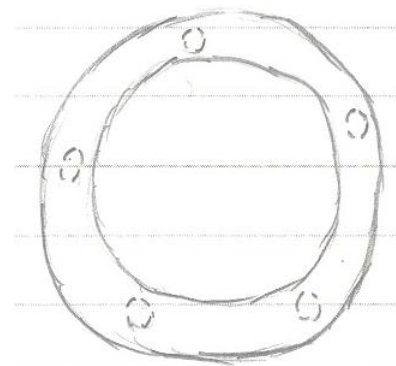

Top view

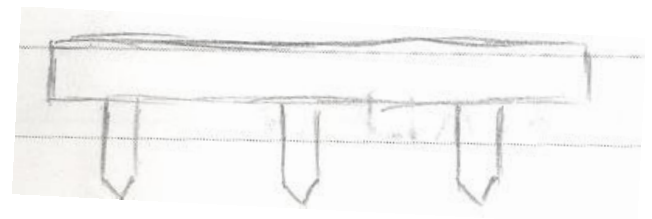

Lateral View

Figure D1.3 Superior Lid [D.1.A.3]

DESIGN 2

This design consist in a the plastic bucket, 2 plastic cones, the plastic cast, 2 clay disk and 1 bowl of clay

Advantages

- ☞ There is the possibility to address different contaminants due the versatility of 3 layers.
- ☞ Light in weight
- ☞ Leakage is prevented in all stages

Disadvantages

- ☞ Collection of water in the same container
- ☞ Complexity in the cones

Regarding this second design some different shapes for the disk were treated in theory and the next issue arises. Depending on the flow rate, is needed to decide if the surface is going to be flat, curved or with another specific shape. The reason for this is that depletion of colloidal silver can exist if the flow is concentrated at the center (See D.2.B.1).

In response to this questioning we propose to create pathways in the disk in case that high flow is achieved.

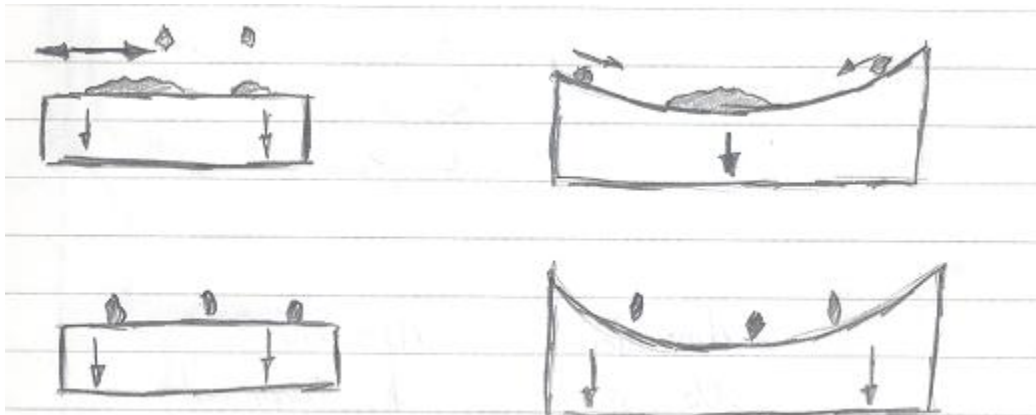

Figure D2.1 Type of surface [D.2.B.1]



Figure D2.2 Creation of pathways [D.2.B.2]

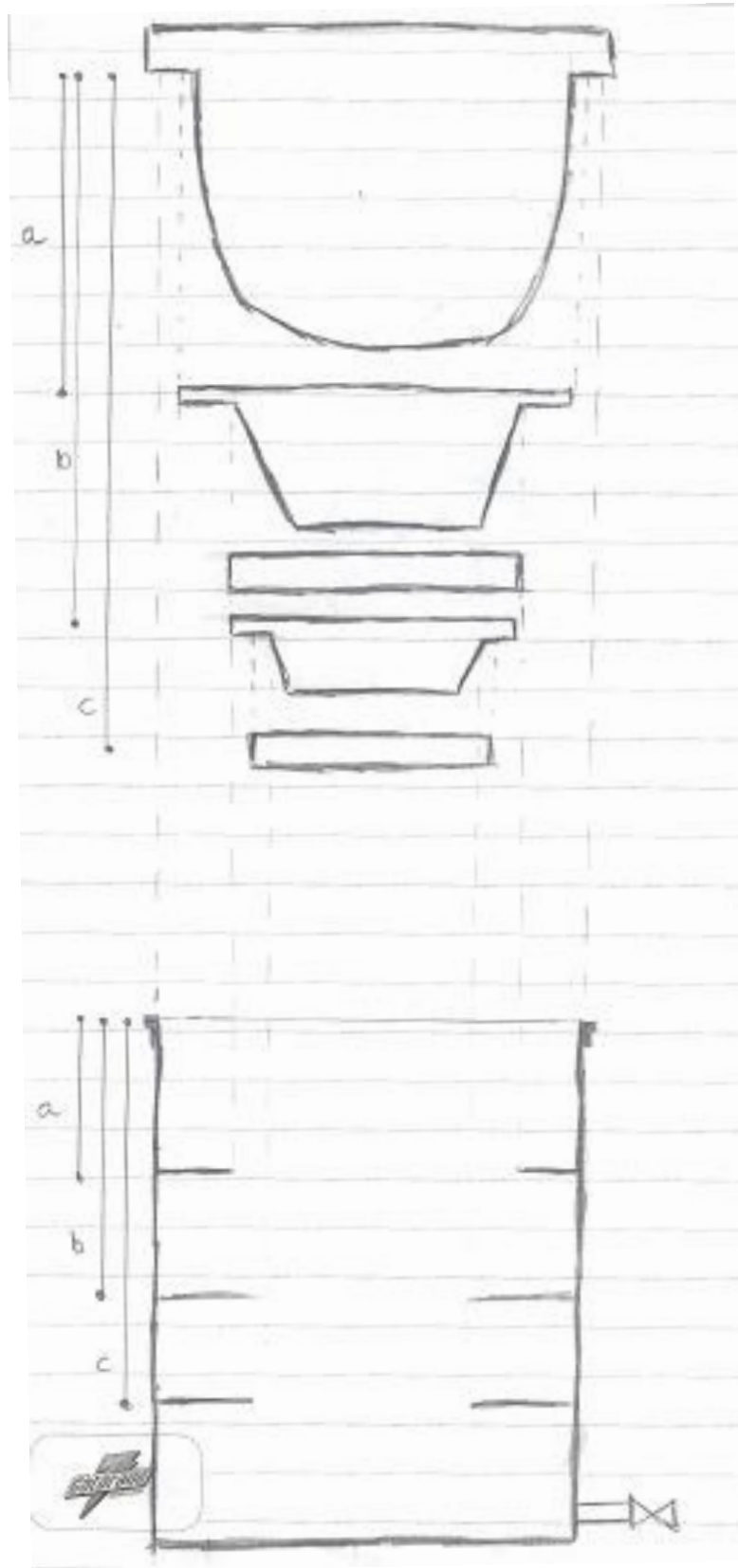

Figure D2.3 Filter structure [D.2.A.1]DESIGN 4

For the NCIIA presentation we need to have prototype working, so we decide to put away the packed bed and construct a sieve tray column with the disks. The issue with the packed bed is that the cost benefit analysis and economic feasibility has not been done, we lack of data.

Due the change from packed bed to sieve tray the problem of leaking arises again, in order to prevent this we are placing simple seals over the structure, changing the disk shape to become a "T" and taking out the slope. All this previous measures are in order to prevent leakage.

The best way to take out the leakage is not treating it, is preventing it. In order to prevent it we need that the water does not pass near the edge of the disks. This is achieved by placing seals not only rounding the disk, but also above the disk so the water can not get the edge. The best type of seal will be one similar to a dike (D.4.B.1), but as is difficult to get this shape we focus on round seals (D.4.C.1).

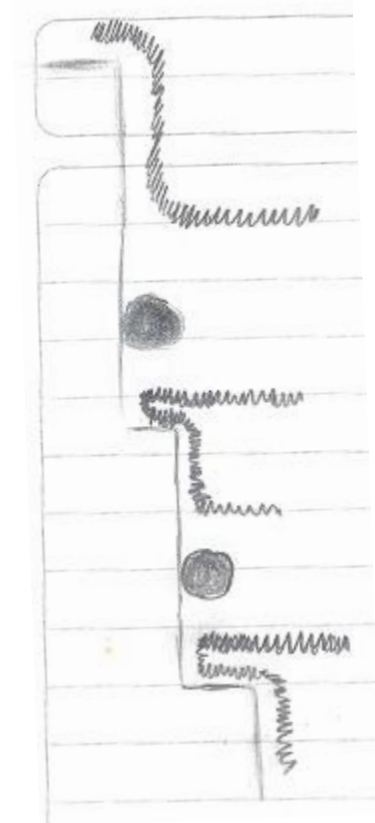

Figure D4.1 Filter structure [D.4.A.1]



Figure D4.2 Dike seal [D.4.B.1]

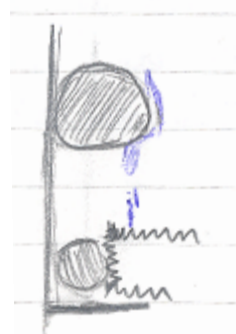

Figure D4.3 Round seal [D.4.C.1]

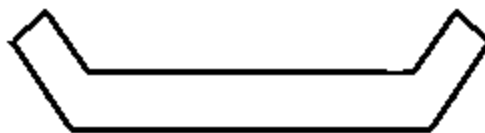

Figure D4.4 Round Support [D.4.D.1]

DESIGN 5

The design 5 is almost the same that the design 4, the difference is that normal round shape disk are used.

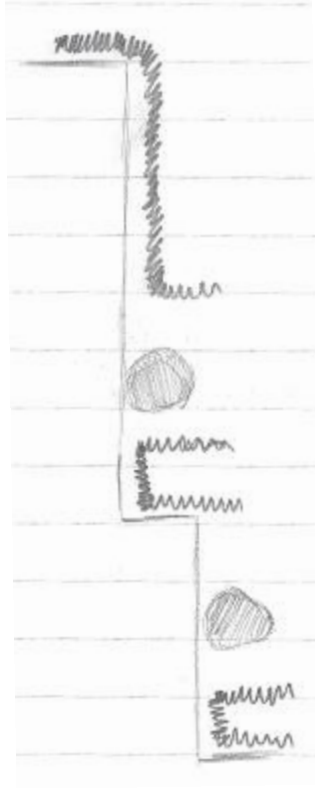

Figure D5.1 Filter Structure [D.5.A.1]

When making test in the lab we figure out that placing seals was not a good solution for the leakage. Even that is works better that not having nothing, the solution was not the best approach. When using flow distributor the best result where obtained. Because of this the design will consist in the shape of design 3 but with flow distributors as design 2.

APPENDIX – COMPOSITION

Report of Lab Work at IIT.

The first compositions that we used were the 6:7 and the 7:7 (sawdust and clay respectively) this on a volume basis, translating these ratios to % weight we obtain 15% Saw Dust and 85% Clay for the 6:7 ratio and 17% Sawdust and 83% Clay for the 7:7 ratio. The sieving number was 10, opening: 2000 micron or 0.78 inches, 9 mesh.⁵

The first flow tests on the 6:7 and 7:7 (Sawdust: Clay) disks and bowls did not go in a good way for certain factors such as:

1. The drying time was too short and the fired bowls and disks were all dusty because bonding of the particulates of clay and sawdust was not achieved. After the first filtration they were not strength enough so the corners of the bowls break down.

The firing time used was 16 hours approximately the first segment was using a rate of 108°F/hr until it reaches 200°F with a hold of 2 hours in that temperature, after that we use a rate of 100°F/hr until it reached 1157°F

2. The thickness of the disks was too big so the flow rate was too slow and it took so much time for the water to pass through the disks.

It takes 10 hours for only 100ml water to pass through the “bowl” samples and 7-8 hours for 20ml of water to pass through “pool” samples.

For the second mixture and after knowing the composition used in Mexico and the flow rate obtained by them. We tried to increase the percentage of sawdust, which is directly proportional to the flow rate. The thickness of the disks was also reduced to have a better flow rate measurement and to get results in a shorter period of time.

First we made a 10:7 ratio or 23% Saw dust and 77% Clay in weight, this mixture was fired with the next program:

The temperature is increased from room temperature to 212°F at a rate of 122°F/hr after that temperature is reached it has a hold of 2 hours, then the temperature is increased by changing the rate to 212°F/hr until it reaches 752°F at that temperature the program has a hold of 4 hours, then the rate is set to 212°F/hr until it reaches 1580°F and hold it for 24 hours.

We also made a mixture with a ratio of 15:7 or 30% Sawdust, 70% Clay this is the ration that the students at Monterey Tech used but we find that for of type of clay and the size of or saw dust it is not a suitable mixture because it has too much sawdust and the clay is not enough to promote the necessary bonding anyways we made two disks with this

⁵ For information about shrinkage see EXCEL spreadsheet of mixture.

composition to see the results but to the rest mixture we added another volume of Clay making it 15:8 ratio or 28% Sawdust, 72%Clay, the result was better but the mixture still having some problems of bonding.

After these findings we also believe that the mesh size of or Sawdust is too big for the powder clay that we are using. We should try to make the mixture with a smaller mesh of sawdust. Thanks to this analysis we recognize the big influence that the size of the sawdust provides to the mixture. The sieving was number 30, opening: 600 micron or 0.0234 inches, 28 mesh.

We sieved some Sawdust with a smaller sieve tray and we are going to prepare more mixture using the 15:7 ratio to test it as soon as possible. The next step is to run some flow rate tests after the firing of the disks is done and compare the results.

With new sawdust size, the mixture is better (clay and sawdust stick together more) than the mixture of the same ratio with bigger sawdust size. The disks for the prototype from the last semester using different ratios specially using the 7:14 ratio using the small size of sawdust.

The next step was to make the pools for the bacteriological tests, the ratios used were 7:10 and 7:14 using the small size of sawdust. For more information about characteristics see Mixture Spreadsheet.

Kiln Records

Run	Description	Intial Temp (°F)	Final Temp (°F)	Start -Final (Time)
1	Kiln treatment first run (It is necessary to secure the door)	70	1160	15.47
2	Kiln treatment second run	64	1160	16.34
3	Firing of the disks with ratio 6:6 (Sawdust: Clay)	69	860	16.45
4	Firing of the disks with ratio 6:7 (Sawdust: Clay)	67	860	16.43
5	Pools and disks ratio 10:7 (Sawdust: Clay)	62	1580	37.35
6	Prototype disks ratio 15:8 (Sawdust: Clay)	44	1580	37.46
7	Prototype disks ratio 14:7 (Sawdust: Clay)	76	1580	37.32
8	Prototype disks ratio 14:7 (Sawdust: Clay)	69	1580	37.34
9	Pools for bacteria test 10:7 (Sawdust: Clay)	64	1580	37.34
10	Pools for bacteria test 14:7 (Sawdust: Clay)	69	1580	

Disk Variables

ID	RATIO		Mesh screen	Prog. Used	Dry Time (hrs)	Observations	Diameter (cm)		%Shrinkage	Empty Time (hrs)	(inf) Recovered	Flow (L/hr)
	Clay	Saw Dust					Before Diameter	After Diameter				
1	7	10	Mesh 9	4	37.16	Small Disk	7.35	7.35	0.00	N/A	N/A	N/A
2	7	10	Mesh 9	4	37.16	Flow rate pool	8.75	8.6	1.71	1.33	27 of 30	0.02
3	7	10	Mesh 9	4	37.16	Flow rate pool	8.55	8.4	1.75	1.52	28 of 30	0.02
4	7	10	Mesh 9	4	37.16	Flow rate pool	8.5	8.45	0.59	N/A	N/A	N/A
5	7	10	Mesh 9	4	37.16	Small Disk	7.35	7.3	0.68	N/A	N/A	N/A
1	8	15	Mesh 9	4	37.46	Disk Prototype	12.6	12.4	1.59	N/A	N/A	N/A
2	8	15	Mesh 9	4	37.46	Disk Prototype	12.4	12.3	0.81	N/A	N/A	N/A
3	8	15	Mesh 9	4	37.46	Flow rate pool	7.85	7.6	3.18	0.19	29 of 30	0.16
4	8	15	Mesh 9	4	37.46	Flow rate pool	8.15	7.8	4.29	0.20	28.5 of 30	0.15
5	8	15	Mesh 9	4	37.46		7.4	7.4	0.00	N/A	N/A	N/A
1 bowl	7	14	Mesh 28	4	37.32	Bowl Prototype	17.1	16.9	1.17	N/A	N/A	N/A
2 s.pool	7	14	Mesh 28	4	37.32	Small Pool prototyp	6.2	6.15	0.81	N/A	N/A	N/A
3 s.disk	7	14	Mesh 28	4	37.32	Small disk prototyp	6.9	6.8	1.45	N/A	N/A	N/A
4 b.disk	7	14	Mesh 28	4	37.32	Big Disk Prototyp	12.95	12.85	0.77	N/A	N/A	N/A
5 up pool	7	14	Mesh 28	4	37.32	Flow rate pool	7.45	7.4	0.67	0.68	28.5 of 30	0.04
6 dw pool	7	14	Mesh 28	4	37.32	Flow rate pool	7.3	7.3	0.00	0.67	28 of 30	0.04
1 sm Disk	7	14	Mesh 28	4	37.34	Disk Prototype	6.45	6.3	2.33	N/A	N/A	N/A
2 big disk	7	14	Mesh 28	4	37.34	Disk Prototype	12.6	12.5	0.79	N/A	N/A	N/A
3 Pool	7	14	Mesh 28	4	37.34	Flow rate pool	7.95	7.55	5.03	N/A	N/A	N/A
4 Bowl	7	14	Mesh 28	4	37.34	Bowl Prototype	16.95	16.8	0.88	N/A	N/A	N/A
1	7	10	Mesh 28	4	37.34	Bacteria Test	8.25	8.2	0.61			
2	7	10	Mesh 28	4	37.34	Bacteria Test	8.2	8.1	1.22			
3	7	10	Mesh 28	4	37.34	Bacteria Test	8.1	8	1.23			
4	7	10	Mesh 28	4	37.34	Bacteria Test	8.1	8.05	0.62			
5	7	10	Mesh 28	4	37.34	Bacteria Test	8.1	8	1.23			
6	7	10	Mesh 28	4	37.34	Bacteria Test	8.05	7.8	3.11			
1	7	14	Mesh 28	4		Bacteria Test	7.25					
2	7	14	Mesh 28	4		Bacteria Test	7.35					
3	7	14	Mesh 28	4		Bacteria Test	7.2					
4	7	14	Mesh 28	4		Bacteria Test	7.25					
5	7	14	Mesh 28	4		Bacteria Test	7.4					
6	7	14	Mesh 28	4		Bacteria Test	7.4					
7	7	14	Mesh 28	4		Bacteria Test	7.4					
8 disk	7	14	Mesh 28	4		Disk for porosity						

APPENDIX – BACTERIA TESTING

Step 1: Preparing soy broth solution

- 15g soy broth
- 0.5 ml deionized water
- Mixing
- Heating gently until boiling
- Keeping boiling for 10 minutes

If there is autoclave, we will autoclave the solution in 15 minutes at 121°C instead of boiling.

- Keeping the solution in bottle (picture 1) in 1 day → activate the solution before introducing the bacteria



Picture 1

Step 2: Preparing the disks

- For each ratio of clay-SAD, use 2 disks
- 1 control disk, without brushing with colloid silver
- 1 test disk, brushing with 2 ml of colloid silver both inside and outside the disk (for future experiment, the amount of colloid silver will vary to make comparison and estimate efficiency)

Note: + using soft brush → avoid abrasion
+ brush soaked with colloid silver before brushing the disk → avoid the absorption into the brush

- Let the disk dry
- Before filtering, wash the disk to remove clay particle

Step 3: Growing bacteria

- Saturate the soy broth with air (picture 2)



Picture 2

- Introduce the freeze-dried bacteria

Aseptically add 0.5 ml of liquid medium to the freeze-dried material with a sterile Pasteur pipette and mix well. For bacteria, transfer the **total mixture** to a test tube containing 5 to 6 ml of the recommended broth

- Keeping the bacteria-broth solution in incubator at 30°C for 1 day.

If there is incubator (with shaking and heating function) and air injection, we don't need to saturate the broth solution in advance and the bacteria can grow better.

Anyway, the result shows that the bacteria grow well (picture 3 and 4: the bacteria-broth solution becomes more turbid and there are a lot of white clusters, which are the bacteria)



Picture 3



Picture 4

Step 4: Preparing the clean bacteria solution

- 100 ml of bacteria-broth solution
- Centrifuging until the bacteria cells and the broth are separated

(The surface solution is less turbid and there are white cells in the bottom of the centrifuge tube) (picture 5 and 6)

Note: for good centrifugation, the centrifuge tube should contain only one half of its capacity.



Picture 5

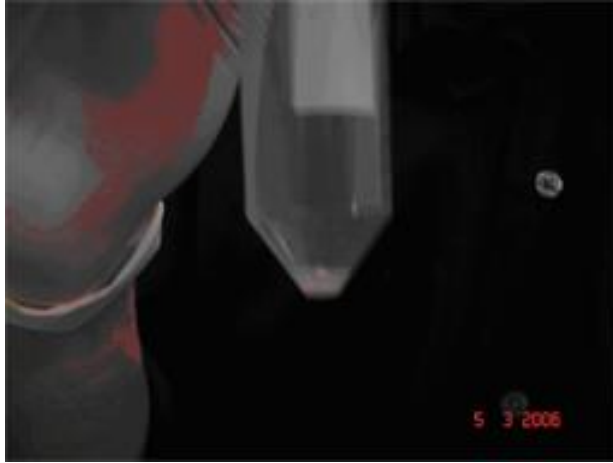

Picture 6

- Remove the surface solution
- Mix the bacteria cells with 150 ml deionized water (the amount of water depending on the number of the disks tested, 20ml/disk and the amount of bacteria cell collected) → clean bacteria solution (picture 7 and 8)

Note: use this 150 ml water to rinse the centrifuge tubes.

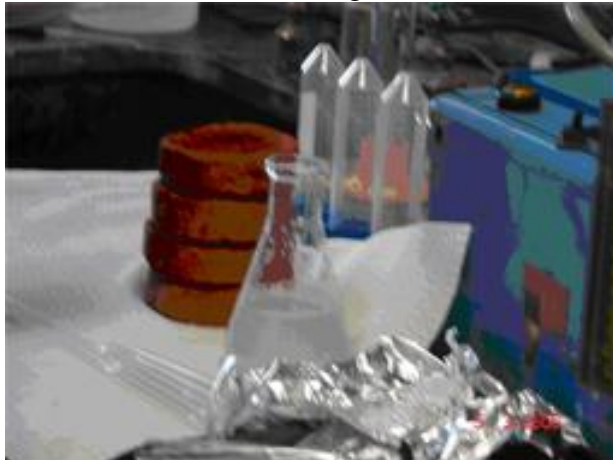

Picture 7

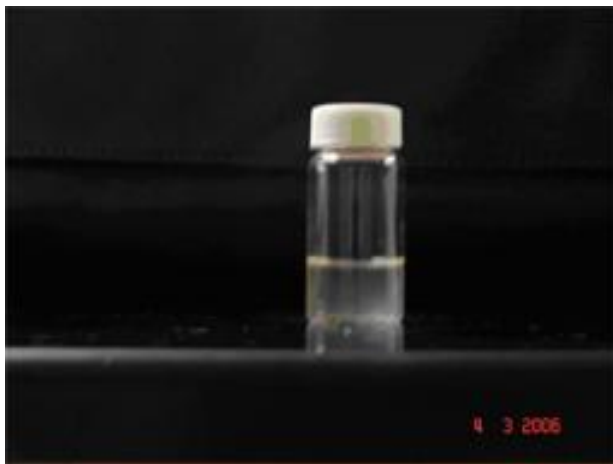

Picture 8

Step 5: filtering

- 20 ml clean bacteria solution/disk
- Passing through the control and the test disks (picture 9)



Picture 9

- Measure the time (flowrate) and the amount of solution collected
- Put the collected solution into vials (already labeled)

In Wednesday experiment, the solution from control disks is light yellow and the solution from test disks has clay particle. There is more solution from controlled disks than from test disks.

Possible reason: control disk is washed before filtering, test disk not.
(The picture of collected solution has not been uploaded yet)

Step 6: Staining

Staining Bacteria in Suspension with either Kit L7007 or L7012

2.1 Combine equal volumes of Component A and Component B in a microfuge tube, mix thoroughly.

2.2 Add 3 μL of the dye mixture for each mL of the bacterial suspension. When used at the recommended dilutions, the reagent mixture will contribute 0.3% DMSO to the staining solution. Higher DMSO concentrations may adversely affect staining.

2.3 Mix thoroughly and incubate at room temperature in the dark for 15 minutes.

2.4 Trap 5 μL of the stained bacterial suspension between a slide and an 18 mm square coverslip.

2.5 Observe in a fluorescence microscope equipped with any of the filter sets listed in Table 1.

KlarAqua
– MIDTERM REPORT –
SPRING 2006



SSB 550/IPRO 335

PROF. NASRIN KHALILI

PROF. JIM BRABAND

BUSINESS TEAM MEMBERS:

SEUN CRAIG
AMANDA GILLIAM
LAURA GRIMMER
ESMERALDA JIMENEZ
CHRIS PRIMOZIC

TABLE OF CONTENTS

Executive Summary	3
<i>Mission</i>	4
<i>Business Type</i>	4
Individual Assignments.....	4-6
Market/Customer Situation.....	8
Market Assessment.....	7-8
Competitors.....	9
<i>Funding Competition</i>	9
<i>Potters for Peace</i>	9
<i>Oxfam Organization</i>	9
<i>The International Committed of the Red Cross</i>	10
<i>Alternative Competitors</i>	10
<i>Government or community water treatments strategies</i>	10
<i>Bottled Water</i>	11
Differentiators.....	11
<i>Value Proposition</i>	11
Benefits for the Customers.....	12
<i>Tangible and Intangible Benefits</i>	12
Risks and Possible Solutions Plan.....	13-14
Marketing Messages.....	14
Go-To-Market Strategy.....	14-15
<i>Introductory Workshop</i>	15
<i>Follow-up Workshop</i>	15
Go-To-Market Readiness.....	15
<i>Logo</i>	16
<i>One-Page Abstract</i>	16
<i>Brochure</i>	17
<i>T-Shirts</i>	17-18
Funding.....	18-19
Cost Analysis	19-20
Future Tasks – Current academic semester.....	20
Future Tasks - Recommendations	21
Contact List	
<i>Illinois Institute of Technology and Monterey Tec</i>	21
Appendix - Individual & Team reports	22
<i>Team</i>	22-31
<i>Individual</i>	32-44

EXECUTIVE SUMMARY

KlarAqua was initiated as an Interprofessional Project (IPRO) at Illinois Institute of Technology (IIT) during the Fall 2005 academic semester. Two teams (design and business) worked closely to run intensive testing of the filter and on developing the business plan.

Our goal for this term (Spring 2006) was to strengthen the business plan by identifying further the market segments including market and customer situation, competitors, differentiators (tangible and intangible benefits for the customer), risks and mitigation plans, marketing messaging, marketing strategy, marketing readiness, cost analysis and funding. All to be performed with the help of our counterparts in Monterrey, Mexico – Monterrey Tec's business team.

Before each member began research on the areas mentioned above, two major decisions were reached: mission statement and type of organization. The decision for type of organization was reached as nonprofit.

Our research shows two types of competitors: funding and alternative. KlarAqua's differentiators such as relationship with Monterrey and our goal to educate community members are also explored. The risk in terms of funding, quality control and customer acceptance are explored and possible solutions are provided.

Marketing messages have been analyzed in order to market KlarAqua as a health promoter and not just as a filter. We believe that is imperative to show the health benefits and as such, they should be communicated through our marketing message. Our marketing strategy will consist of utilizing the following three powerful tools: writing, speaking and word of mouth. These tools will be exercised during two workshops: Introductory and Follow-up. Go-To-Market Readiness has been started with the development of a brochure and 1 page abstract. The logo has been improved and will be printed on polo shirts.

In terms of funding, our team submitted a proposal to GE in December 2005 and a proposal to P3 in February 2006. We have high hopes that our proposal towards the P3 award will at least go to the second phase with the opportunity to compete for \$10,000.

A contact list, which includes the information of our counterparts in Monterrey Tech is provided. Individual tasks to be completed by the end of the Spring semester (2006) as well as recommendations for future IPRO teams are listed at the end of this report. Lastly, our Appendix section contains all progress reports from each team member. These reports detail individual work and time devoted to this project

Mission Statement

In order to find a focus, the business team decided to develop a mission statement that can be used as a guidance to further establish KlarAqua as an organization. The process for deciding a mission statement was for each member to submit a first draft of a mission statement. The drafts were reviewed and revised with the following 10 key words in mind:

1. World/global
2. Education
3. Support
4. Non-profit
5. Health
6. Sustainability
7. Training (capacity building)
8. Economic Development
9. Rural
10. Accessible

The revised mission statement is as follows:

KlarAqua is devoted to supporting and educating communities in rural areas of third-world countries via development, construction and use of a low-cost clay-based, water purification system which promotes the local economy and improved health conditions.

Type of Organization

Nonprofit

Another achievement was finding agreement among the business and design groups on KlarAqua's business type. Most of the business members expressed a strong desire to see KlarAqua as a nonprofit organization given the nature of its origin which was through the help of students and faculty members. Its origin from academic institutions was obvious to serve the community. The business team understands the importance of profits which are necessary to be invested back into KlarAqua to secure not only its existence but also its level of quality. However, the team believes that no individual should enjoy the profits for personal needs.

INDIVIDUAL ASSIGNMENTS

The business team consisted of 5 students, including the team leader. In order to accomplish our goal to improve KlarAqua's business plan, each member was assigned to work on or more one business area. The business areas and order of assignments are as follows:

- Market and customer situation (Chris)

- Competitive Positioning and Key Differentiators (tangible and intangible benefits) (Seun)
- Risks and Mitigation Plan (Seun)
- Market Messaging and Marketing Strategy (Esmeralda)
- Go to Market Readiness (Amanda)
- Funding (Laura)
- Cost Analysis (Chris and Seun)

The business areas were identified based on last semester's status of the of KlarAqua's business plan. The team felt that overall the business plan needed significant improvement. Although each member was assigned to one or more business areas based on their individual skills and initiative, members contributed to a great extend in all areas.

The business team leader observed and measured during the first two team meetings the individual skills of each member. Criteria for assignments are as follows.

Chris a business major and interest in the exploring the living conditions in poor areas was assigned the Market and customer situation. Cost Analysis was later assigned to Chris and Seun.

Seun an MMAE major, showed interest in learning more about management and potential competitors. His skills were utilized for analyzing the competitors, KlarAqua's differentiators and benefits (tangible and intangible), risks and mitigation plans for the customer. Cost Analysis was later assigned to Seun and Chris.

Amanda's skills in architecture and creativity were utilized to improve the logo and development of marketing materials. Later in the semester, Amanda's knowledge in the intricacies of clay and plastic properties were used in the actual design of the filter as well as the development of 3D images.

Laura's intensive background in working in poor communities of South Africa and great writing skills were utilized in writing proposals to increase our funding capabilities.

Esmeralda's marketing and management experience was utilized for development of market assessment, marketing messaging and marketing strategy in addition to leading the team.

Below is an illustration of the initial plan for individual role assignments.

KlarAqua's situation

Illustration of Business Strategy

MISSION STATEMENT:

KlarAqua is devoted to supporting and educating communities in rural areas of third-world countries via development, construction and use of a low-cost clay-based, water purification system, which promotes the local economy and improved health conditions.

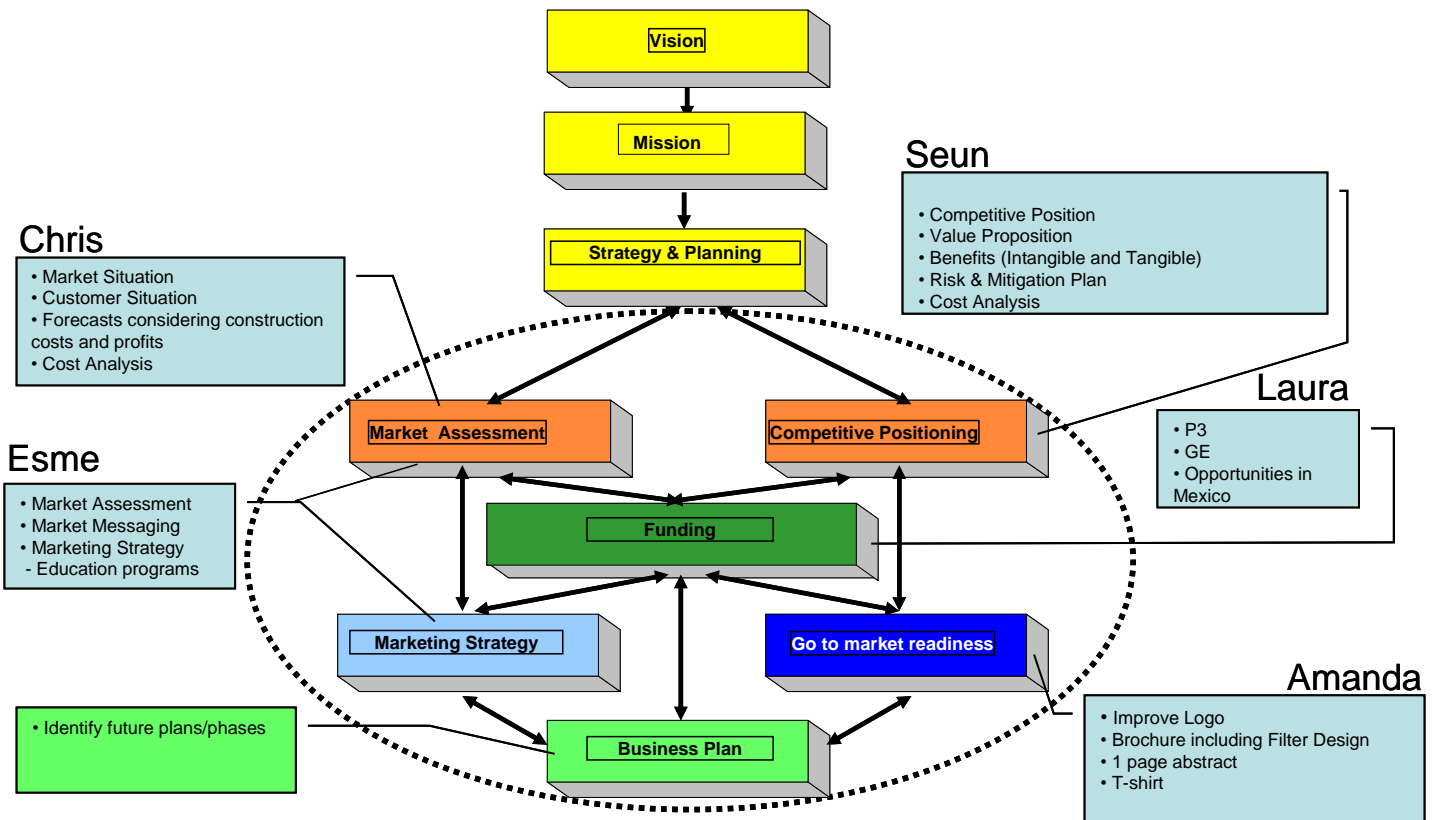

MARKET ASSESSMENT

From information gathered by our counterparts in Monterrey, we can asses our market size. Their progress report illustrates the most rural states in Mexico. The figure below shows the states of Campeche, Chiapas, Guerrero, Hidalgo, Oaxaca, Puebla, San Luis Potosi and Tabasco as the states with the largest rural areas.

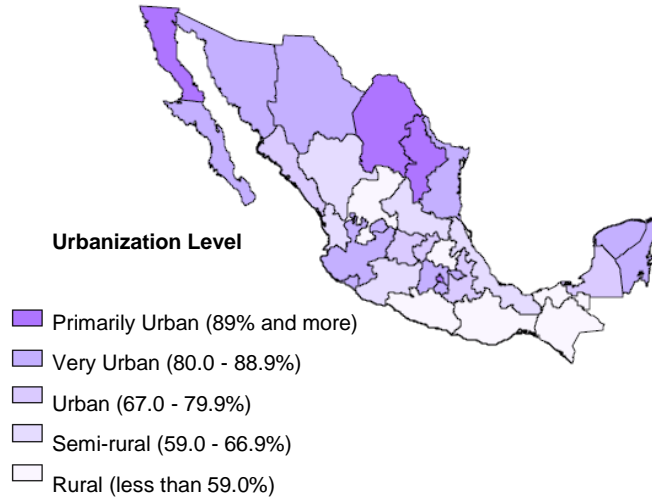

The figures below show the states mentioned above with a further illustration of their rural and non rural areas composition. The first group of states with the largest rural portions is: Oaxaca, San Luis Potosi and Chiapas. Second largest: Guerrero and Hidalgo. Third largest: Campeche and Tabasco. Fourth: Puebla. Give the data provided we can estimate our market size as 4,000 potential KlarAqua customers.

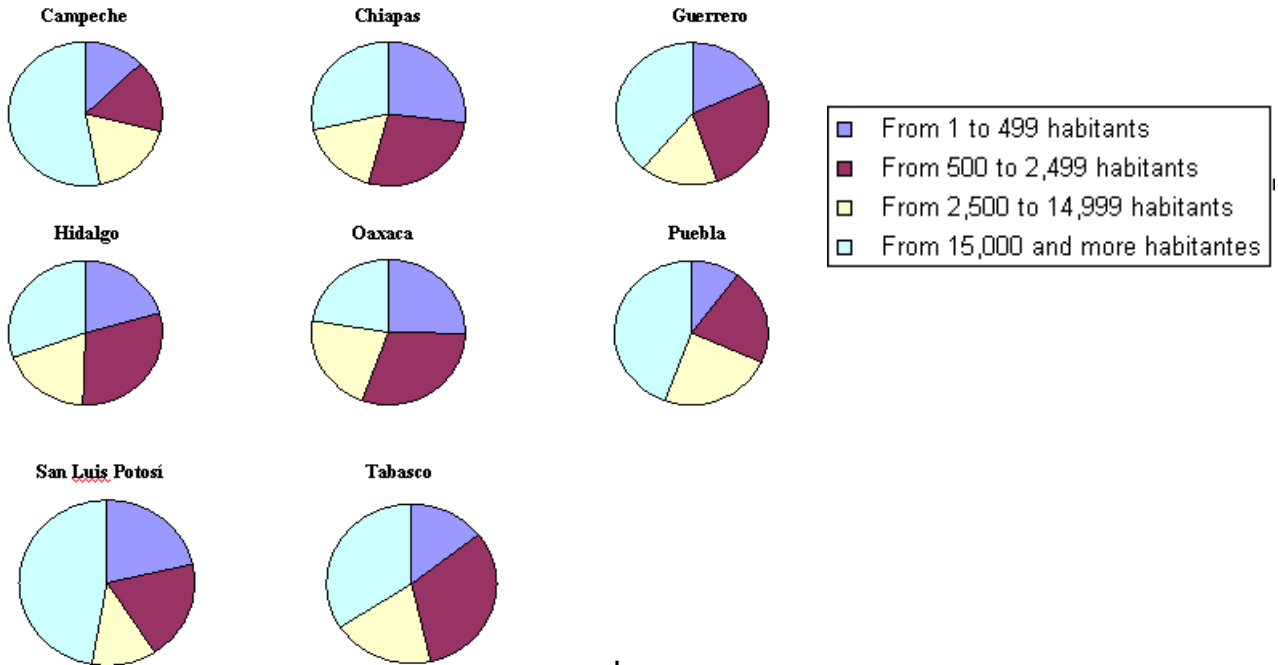

Mexico is a growing country. Much of Mexico has improved drinking water, around ninety one percent. Literacy is not a large problem either. Around ninety two percent of the male population and eighty nine percent of the female population are literate. While these statistics may say a lot about Mexico overall it does not provide enough insight to their communities and what some of the underlying problems are in these communities. Improved drinking water was a step in the correct direction with Mexico. People are still becoming ill and dying because of water contaminants. Mexico is becoming more urbanized every year. From 1970 to 1990 grew by about 3.6%. From 1990 to 2004 it grew by another 1.9%. In these urbanized areas water is carried through tubes to outlying communities. These tubes carry improved water and carry smaller amounts of contaminants. This is an improvement but can still make someone sick. Mexico is a growing country with many needs. Ten percent of their population still earns under a dollar a day. These people are the ones that will need a low cost water purification system the most.

MARKET/CUSTOMER SITUATION

Anyone who desires clean water available at their own convenience is a potential customer for KlarAqua. Most of Mexico has improved drinking water. Improved water does not mean clean water. The water is improved but contains smaller amounts of contaminants. Large sections of Mexico are rural areas with fewer resources to obtain clean water. Pesquería, Nuevo León is an example of a community that has a way of obtaining clean drinking water. In communities like this one bottle service is delivered to homes and markets. However the water is costly for a home, about ten to fifty pesos a week depending on usage. While much of the community is set on drinking bottled water it is not affordable for everyone. Some families (2%) obtain their water from a tube that is cleaner but not necessarily drinkable. Also four percent of the population in Pesquería, Nuevo León uses a different method of obtaining clean water.

Most other communities are not as well developed as Pesquería, Nuevo León. While Nuevo León is mostly comprised of communities that have more than seven hundred residents in their one hundred seventeen communities many other states in Mexico are not as fortunate. States such as Chiapas, Oaxaca, and Veracruz are comprised of communities with fewer than five hundred residents in rural areas. These areas are less likely to receive bottle or tube water. These smaller rural communities have fewer resources to deal with the ailments of non clean drinking water. On average it cost a family ten to fifty pesos per doctor visit and if treatment is needed another sixty to one hundred thirty pesos for water born illnesses. In smaller undeveloped areas of Mexico a cheap source of water purification is needed.

COMPETITORS

The product as well as the service that we are trying to provide is one that we would rather have more people who are doing the same thing and as such, we are not trying to set up a niche market in the same sense as most other businesses are. Being a Not for Profit organization we require funding. The competitors listed below include both other organizations that are liable to try and obtain funding for our similar goal as well as alternative sources of drinking water for rural regions of Mexico. These are the parameters we used in looking at competition to KlarAqua.

Funding Competition

Potters for Peace: Filtron Water Filter Technology

Potters for Peace (PFP) “seeks to build an independent, non-profit, international network of potters concerned with peace and justice issues. They will maintain this concern principally through interchanges involving potters of the (overdeveloped) North and (underdeveloped) South. PFP aims to provide socially responsible assistance to pottery groups and individuals in their search for stability and improvement of ceramic production, and in the preservation of their cultural inheritance.

Potter’s for Peace decided to build a factory (with about 4 potters as full time workers) from which primary production of the products was carried out for that region. However, PFP works to introduce the filter for general use in developing countries by establishing micro-enterprises of artisans making the filters and receptacles, and by partnering with NGOs that distribute the filter and provide education.

Some of the benefits of the PFP Filtron filters are that the filters remove bacteria including E-Coli and vibrio cholera as well as giardia and cryptosporidium. The filter itself is an approximately 10” wide by 10” deep open-top clay cylinder which after firing is coated with colloidal silver, a well known microbicide which remains in the filter for years. The rate of filtration is determined by the mixture of combustible material, generally sawdust which is added to the clay before firing. The treated filter is then placed in a plastic or ceramic receptacle with a lid and faucet. Filter units are sold to individuals or NGOs for \$12 for a basic plastic receptacle with more expensive clay receptacles available. Replacement filters cost about \$4.00. Production and transportation costs vary of course from country to country.

Oxfam Organization

Oxfam is a non governmental agency which is originally started in the United Kingdom but has plenty of other countries that it does a lot of work in. Oxfam is concerned with a lot of the issues

that are faced in third world countries such as wide spread hunger and poverty as well as sickness and health education. One of the things that Oxfam does is also to try and increase health in these areas through education on the benefits of safe drinking water and good clean food.

Oxfam has huge warehouses where it keeps equipment and its main route of helping is by responding to emergencies and sending the equipment to areas that need it. Afterwards, Oxfam stays in the area and tries to support and help the community to recover from that disaster.

In terms of water filtration, which is the focus of how they are a competitor with us, Oxfam does a lot of clean water supplying directly and also help in education by teaching the community about boiling water. One good example that recently happened is the Tsunami in India. Oxfam is currently working there and is supplying hygiene kits to the villages affected in the hopes of helping them stay healthy. There is also an Oxfam base set up there with teams of experts in water and sanitation, food and nutrition and public health as well as hundreds of volunteers.

The International Committee of the Red Cross

This is the largest organization in terms of non governmental and not for profit organizations in the world. It is made up of several smaller networks of organizations like the American Red Cross and the British Red Cross to name a few. The aims of the Red Cross are many. The Red Cross operates under the humanitarian operation and is a Swiss-based humanitarian organization working globally and enjoying international legal status. The Red Cross is neutral, impartial and independent, working in armed conflicts and other situations of violence and are the guardian of international humanitarian law

(Set forth by the Geneva Conventions).

The Red Cross goes to places where there is violence, poverty or suffering and helps with trying to make sure the rights of the individuals even in those remote areas are not trampled on. They provide education as well as food, water and are completely funded by a combination of companies, governments as well as individuals.

ALTERNATIVE COMPETITORS

Bottled water

For example: Embotelladora Aqa de Mexico S.A. de C.V., one of the largest water bottlers in Mexico, asked NSF International (a well known Not for profit company) to certify all 18 of its water bottling plants. The project, slated for completion next year, will make NSF certified bottled water

available to 80 percent of the country's consumers. By doing this, the bottled water company is making itself more marketable as a source of good drinking water.

Government or community water treatment strategies

If the government decided to suddenly be more concerned with upgrading facilities or investing more money in water treatment to the more rural communities. This is not necessarily a bad thing as we can use these as a primary source of water instead of a stream, river or well and then the KlarAqua filter can be used to filter the government sponsored water. This is likely especially because there isn't going to be a water treatment facility attached to a small rural community.

Bottled Soda

There is a trend where instead of replacing safe drinking water with bottled water, some communities are more able to rely on bottled soda instead for drinking. This is both unhealthy because of the cost and the fact that there is a high sugar content in those drinks. This is more prevalent in the same areas that are able to get access to bottled water

DIFFERENTIATORS

Value Proposition

In contrast to Potter's for Peace, we are not concerned with developing a factory ownership model and then depending on other organizations to purchase, distribute the filters and educate on it's usage. We are more concerned with the education of the communities and the teaching of skills and practices which are easy for the potters and the community to share. Our business focus is more practical and the results are a lot faster in terms of dealing with the issues we are trying to address.

Additionally, we are not selling actual units of a finished product. The price of the product even though having to be somewhat reasonable is not our primary concern as we are not in charge of the manufacturing process. KlarAqua is more able to focus on properly passing on the techniques rather than on the business model of selling units. This is hand in hand with the ingenious three tiered system of our filter. The water has to go through three different levels of contact with bacteria killing materials and this will help in killing a maximum amount of bacteria as well as opens up the opportunity to have filters with different compositions.

KlarAqua is focused on the problem of unsafe drinking water and how to change that situation in developing countries. We are aware of other issues such as poverty and sickness, but are

focused on solving one problem now and this makes us more streamlined and likely to remain successful rather than trying to tackle a lot of issues simultaneously like some other companies. Since Safe water is a basic physical need, we are confident that once it is accessible to the community, they will be able to reduce the other issues like sickness and poverty.

In addition, KlarAqua has a clear advantage with the partnership between Illinois Institute of Technology and the Technology Institute of Monterrey. There are two levels at which the project is being worked on; the local level and the outside level. By having a team of experienced and dedicated individuals able to relate to the project and the customers on a personal level, we are more attuned to the needs of the community and we can better serve the customer.

Furthermore, our relationship with Monterrey Tec will help KlarAqua to gain the trust to community leaders, government officials and poor community members. The fact that the filter is being design, developed and tested with the collaboration of students who attend Monterrey Tec, which is considered the top engineering institution in Mexico, will help KlarAqua to establish itself as a credible source.

BENEFITS FOR THE CUSTOMER

Benefits of KlarAqua

There are two types of benefits of our business to our potential customers. There are both tangible benefits as well as intangible benefits. Some of these are measurable in terms of either money or alternative known values and the intangible benefits are those which cannot be quite measured. Some of these benefits include:

1. KlarAqua is not selling a product, but a technique or skill. This has more long term sustainability for the community.
2. KlarAqua's process is set up for easy entry into the eventual community. Rather than rely on a distribution model through another organization, we have to physically go into a community to train the artisans with our unique positioning through the Institute of Monterrey which is local.
3. There is more focus on education and training the community and this is a huge benefit as we do not have to worry about the financial and managerial implications of running a production facility.
4. The time frame for the process from coming into contact with a community to leaving them in a situation where they have safe drinking water is shorter because we do not have to deal with issues such as production, distribution, sales and storage. The

devices are made as needed by members of the community and they control such variable as price as well as volumes.

5. The costs, as well as the monetary benefits of the process are within the community. There is a good chance for an economic stimulation as healthier people can perform better and there is the possibility of economic development. There are cost savings such as money that would have gone to buying bottled water or to a health center for treatment from sicknesses related to unhealthy water. This is a unifying theme for the community and helps to increase interaction and the general wellbeing of the community as a whole.

RISK & POSSIBLE SOLUTIONS

1. Since KlarAqua is training the artisans independently, there is the risk that the technique is not quality controlled from one artisan to another. Since the product is eventually going to be made by artisans or in the community, it is likely that mistakes are possible which would render the device less effective than when we tested the device in the laboratory. This might be due to the fact that the potters are not properly trained and we can try to mitigate this risk by providing workshops and educational resources to help the potters be more productive.
2. The potters and artisans need to be supplied with the silver and might need some other types of support. There is the risk that there might still have to be a dependency on KlarAqua in other for the community to stay healthy. This is undesirable and can be eliminated by providing a distribution model or system within which the community is responsible for as much as possible without the intervention of KlarAqua.
3. KlarAqua is a Not for Profit organization and this makes funding an essential part of our business focus. As such there is the risk that we might run out of funding by not getting enough grants to keep the projects active. This risk can be mitigated by applying a documentation model to our business. We will make sure to show how our involvement with the communities is helping them out. This we can then use to show why we need more money to replicate the strategies in a new rural community which has a need for clean safe water.
4. The fact remains that we are trying to make a community adapt their lifestyle and their behavioral patterns to a healthier one. This is not an easy project to accomplish as it is difficult to break habits and in these rural communities, there usually exists a resistance to change or interaction from the outside world. The inherent risk here is one of rejection of our whole idea. Some of the ways that this can be minimized is by using the community leaders to get into the community as well as using success

stories from other such communities to entice them. Once we can get a small portion of the community interested and using the filters, the results will be able to persuade the rest of the community.

MARKETING MESSAGES

KlarAqua's mission should be reflected in its marketing messages. It is important for KlarAqua to emphasize the health benefits it provides and not to fully focus on its capabilities of cleaning water. In order to be successful, KlarAqua must establish confidence in terms of its benefits. It is important to take under consideration KlarAqua's mission in its marketing message. The goals are as follows:

- Promoting health and local economy
- Bringing unity among communities which transforms into high morale
- Eliminating bacteria in water that causes illnesses
- Providing clean water that prevents obesity and diabetes (caused by soft-drinks)
- Providing an instant remedy

The proposed message is the following:

"Helping communities to grow and enjoy healthy lives"

GO-TO-MARKET STRATEGY

With the help of our counterparts in Monterrey, we are in the process of gathering more data in the following areas: demographics, communication, technology, water access, health, etc. After gathering this data we will be able to explore other ways of marketing such as ads in Billboard, TV, Radio and Newspapers and Magazines.

Our immediate strategy is to take advantage of the three most effective tools for nonprofit organizations: writing, speaking and word of mouth.

These tools are essential to KlarAqua since funding is its preliminary stages therefore, it is important to show the benefits of KlarAqua via the most inexpensive, yet powerful tools.

Writing is already in action with the development of brochures and one-page abstract (please see Go-To-Market Readiness). The marketing materials should be distributed to community members, clinics, schools, churches, etc. Also, for future semesters we propose the development of a webpage to attract a mass audience for funding opportunities and to find publish articles in the targeted communities' publications (hospitals, clinics, schools, churches, etc.). *Speaking* will be exercised through the *Introductory* and *Follow-up* workshops (described below). Lastly, *word*

of mouth will be exercised through success stories which will be documented and spread in the Follow-up workshop.

The following two workshops should be performed by local individuals who share their background, culture and spoken language.

Introductory Workshop

Develop an introductory workshop that can be utilized to educate communities on how KlarAqua's filter works and to generate awareness on its immediate health benefits.

Key Factors to be considered for introductory workshop:

- Engage community leaders and government officials to emphasize KlarAqua's quality and importance.
- Make it clear to the audience that KlarAqua is not asking for money but instead offering help.
- The presenter should utilize local water to demonstrate how the filter works.
- The presenter should drink the water to show confidence.
- Emphasize how easy it is to clean and how fast it is processed
- The presentation should be given in the local spoken language. Written instructions on how to use the filter should be provided.
- If literacy is absent, demonstrate the instructions utilizing images that depict the actions.

Follow-up workshop

Develop a follow-up workshop to ensure people are using the filter properly and to establish KlarAqua as a health promoter. During this workshop it is also important to identify any premature problems with KlarAqua's filter (if any) and to investigate the image that KlarAqua is establishing among its users. The main goal at this phase should be to establish integrity.

Key Factors to be considered for follow-up workshop:

- Document and spread success stories
- Communicate secondary health benefits such as: weight loss, reduced risks of diabetes and obesity (caused by soft-drinks).

Source: <http://www.pubmedcentral.nih.gov/articlerender.fcgi?artid=1323307#B8>

GO-TO-MARKET READINESS

The business team recognizes the importance of marketing to attract opportunities for funding and to generate awareness of KlarAqua's mission. The following materials were developed to achieve our marketing goals.

Logo

The process of refining KlarAqua's logo is in its last stages. In order to effectively reach our audience we need a logo that conveys our mission and message while retaining a level of quality and professionalism. The new design can be used at presentations on poster boards and brochures to help gain support and receive monetary contributions. It can also be used as a tool to create educational devices for the seminars to be conducted in Mexico once KlarAqua is in the latter stages of product development and implementation.



One-Page Abstract

Following is the one-page abstract that was written which helps convey KlarAqua's mission, establish its goals, and market its product.

Numerous reports by the United Nations and the World Health Organization have indicated a significant worldwide problem with water pollution and accessibility to potable drinking water exists. Due to technological and economical barriers, the problem with water pollution is particularly more serious for under-developed and developing countries. Current water purification systems including sand filters, bio-filters, chlorination units, solar-based systems, and clay-based filters are branded globally as a means to address this problem. However, these systems have presented considerable limitations with their applications including high cost and lack of availability in rural areas. In conjunction with continuing and intensive worldwide efforts to address water pollution problems and accessibility to potable drinking water, researchers at Illinois Institute of Technology and Tecnológico de Monterrey have developed a low-cost, clay-based water purification system called KlarAqua for developing countries and sensitive areas in need of clean water. Focusing on sustainable development, KlarAqua's mission is to promote health, hygiene, and economic prosperity. KlarAqua was developed taking into consideration local water usage issues, cultural factors, and social economics. During a recent pilot study in rural communities of Monterrey in Mexico, engineering and economic feasibility of KlarAqua were evaluated. Results of the pilot study have indicated simplicity of design, potentiality for local material use, and ease of production empower inhabitants to build, commercialize and use this system locally. The system can be easily modified to extend its reach beyond Mexico to provide other developing regions of the world with potable drinking water.

Brochure

Development of a trifold brochure has begun that can be distributed to business people and companies interested in KlarAqua. It is meant to be used during presentations for grant proposals and monetary competitions. It briefly explains the contaminated water situation in developing countries and how KlarAqua hopes to solve it focusing on innovative design and use of local materials, low-cost production, and economic sustainability. A future brochure is planned that can be distributed to local customers in Mexico explaining who KlarAqua is, what the product is and how it works, and how it will benefit their health and quality of life.

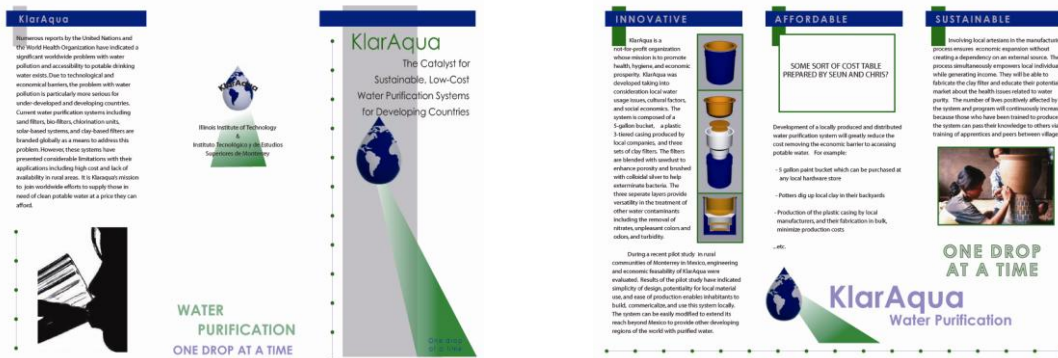

T-shirts

T-shirts with an embroidered KlarAqua logo are currently in development to help give the members of the IPRO 355 team a look of professionalism and unity when giving oral presentations. People will know who KlarAqua is and will take their message and their work seriously. It will also help to convey members' sense of pride in this project and their devotion towards its success. Once the project has been completed, participants will take with them a lasting reminder of the contributions they made to the success of KlarAqua.



Using the new filter design criteria, new presentation boards will be prepared to more effectively and efficiently present this project to others displaying key research and development in a concise and understandable manner. These can be used during the team's scheduled presentations at the NCIIA Conference March 23rd -25th in Portland, Oregon and for the I2P Idea to Product Competition in San Jose, California March 30th to April 2nd. Once all design development has been completed, final presentation boards will be prepared for the group to use at IPRO Day.

To further the graphic components used in KlarAqua's presentations, the task of producing animated slides will be undertaken to help present important information on an interactive level. The animation can be run continuously on a computer or on a TV screen. It can act either as a main informational tool for presenters or as a device to provide potential clients with clarity where words and gestures may not. It will help attract attention and allow presenters to retain peoples' interest while introducing KlarAqua and the water purification system. It is another way to reinforce upon others KlarAqua's mission and goals in a dynamic manner.

FUNDING

KlarAqua's funding will be provided through both partnerships and grants. In both of those areas, we have made significant progress and have numerous opportunities developing. In terms of partnerships, we are looking for organizations with similar vision where we can benefit from their experience and resources. We have utilized our partnership with Monterrey Tech to investigate local markets and aid in product design, and we are investigating further partnerships with international NGO's.

We have found that our project lends itself well to numerous grants. Some examples of grant offers for which we are eligible include: student team engineering innovations, environmentally friendly new technology, catalysts to sustainable development, innovate business plans, water safety and health promotion. We were awarded \$16,000 from National Collegiate Inventors and Innovators Alliance (NCIIA) in Fall 2005. This award was applied toward biochemical tests, a kiln for firing filters, and materials for research and development. We will be attending the NCIIA conference for grant recipients March 23-25, 2006 in Portland, Oregon to present our project to our funders.

KlarAqua has proposed for grants with three other organizations and is awaiting notification for award recipients. We applied for the "GE & Dow Jones: Environmental Business Plan Challenge" which is a \$50,000 award toward business plans offering environmental innovations and profitability. Our application was received in December 2005 and award notification will occur in April 2006. We also applied for the Environmental Protection Agency's (EPA) "P3 Award: People, Prosperity and the Planet Student Design Competition for Sustainability" which focuses on student design innovations benefiting three focus areas in a sustainable manner. The grant is given in two parts: \$10,000 for Phase I award toward continued research, and \$75,000 for Phase II award toward implementation. Our application was sent in February 2006 and winners will be notified in August 2006. Thirdly, we will be competing for a \$25,000 award at the "Idea To

Product" Competition to be held March 30-April 1, 2006 in San Jose, California. This award is for implementation of novel student design projects and business plans.

KlarAqua will require continuous funding for implementation and maintenance. Our search for grants and partnerships will continue as long as KlarAqua promotes health and clean water in developing nations.

COST ANALYSIS

The object below is a preliminary of how much each of the needed objects will cost. However we do not have many of the specifics of how much the product itself will cost because we are missing many of the ingredients of the project. Many of the costs can be figured out by visiting the local supermarket. The prices it cost for clay disks in Mexico with a relevant size but not to scale of our project.

The advice given to us from Stuart's professor was to figure out our company's business plan. This is including how specific pieces of our filter will be manufactured and the costs associated with them. Towards the end of the business plan we should have enough information on how much the filtration system should cost. While we are on the correct path with the financial analysis there are many cost unknowns associated with our product. After we figure out the costs a cash flow diagram and projected cost of the product can be figured out shortly after.

		YEAR 1		YEAR 2		YEAR 3	
		Jan-Jun (YR 1)	Jul-Dec (YR 1)	Jan-Jun (YR 2)	Jul-Dec (YR 2)	Jan-Jun (YR 3)	Jul-Dec (YR 3)
CAPITAL COSTS	PRESENT \$ WORTH						
	Flat Disk		5				
	Reservoir Disk		12.5				
	Plastic Buckets		No Cost yet				
	Internal Bucket Mold		No Cost yet				
	Glue		No Cost yet				
	Silver solution		No Cost yet				
	Cheese cloth		No Cost yet				
	Water		Free				
	Carbon		No Cost yet				
	Sawdust		Free				
	Testing of product						
VARIABLE COSTS							

	Community outreach			
	Education			
	brochures			
	displays			
	handouts			
	Travel			
	Employee training			
	Monitoring			
	Labor			
BENEFITS				
	Health care savings			
	Doctor Visit	60		
	Advanced treatment	120		

*All Prices are given in pesos

FUTURE TASKS (to be completed during current academic semester)

CHRIS

- Continue Cost Analysis

SEUN

- Continue Cost Analysis
- Finalize KlarAqua’s value proposition
- Cash-Flow Analysis.
- Closer Analysis into the two levels of competition
- Analysis of Customer Return on Investment (ROI)

AMANDA

- Finalize brochure designs
- Redesign presentation posters
- Create a computer animations for presentations
- Produce final prototype of the plastic casing
- Create final graphics for the filter design

LAURA

- Presenting KlarAqua at both NCIIA and I2P Conference
- Finding at least 2 more grants for KlarAqua
- Finding profitable partnerships with NGO’s, etc...

FUTURE TASKS (RECOMMENDATIONS)

The following are recommendations for future teams:

1. **Filter Market Assessment**
2. **Develop Forecast of KlarAqua's annual growth**
3. **Pass the "effective technology" test of World Health Organization (WHO)**
4. **Develop KlarAqua's webpage**

CONTACT LIST

Name	School	Location	Phone	Email
Prof. Nasrin Khalili	Illinois Institute of Tech	Chicago, USA	312-906-6546	khalili@iit.edu
Prof. James Braband	Illinois Institute of Tech	Chicago, USA	312-567-5002	bradband@iit.edu
Esmeralda Jimenez	Illinois Institute of Tech	Chicago, USA	312-545-9335	ejimenez@stuart.iit.edu
Laura Grimmer	Illinois Institute of Tech	Chicago, USA		grimlau@iit.edu
Amanda Gilliam	Illinois Institute of Tech	Chicago, USA	920-286-0264	gillama@iit.edu
Chris Primozic	Illinois Institute of Tech	Chicago, USA	708-307-1028	primchr@iit.edu
Seun Craig	Illinois Institute of Tech	Chicago, USA	773-704-2650	craiolu@iit.edu
Dr. Joaquin Acevedo M.	Monterrey Tec	Monterrey, Mexico		jacevedo@itesm.mx
Dr. Enrique Ortiz N.	Monterrey Tec	Monterrey, Mexico		eortiz@itesm.mx
Ing. Flavio Marin F.	Monterrey Tec	Monterrey, Mexico		fmarin@itesm.mx
Marcela Gutiérrez Gorostieta	Monterrey Tec	Monterrey, Mexico		g_marcelita@hotmail.com
Edgar E. Martinez C.	Monterrey Tec	Monterrey, Mexico		A00781548@itesm.mx
Pamela Villarreal	Monterrey Tec	Monterrey, Mexico		pamelavillarreal@hotmail.com
Ana Lucia Cavazos	Monterrey Tec	Monterrey, Mexico		A00269328@itesm.mx

APPENDIX – TEAM (1)

REVIEW OF LAST SEMESTER'S BUSINESS PLAN

OLUWASEUN CRAIG:

ID#: 10371091

IPRO 497-355: Low cost water purification devices for developing nations.
(Spring 2006)

Klaraqua Business Plan critique

- There seems to be a lot of emphasis on Mexico as a market. Are we focusing on starting in that market and then looking at other possible locations or do we want to try and concurrently search the possibility of researching other locations.
- We might want to revisit the objectives from last semester and see if we need to update or change them. Same with the methodology of how they decided to attack the problem.
- I wasn't sure if Klaraqua was going to be a NPO or a LLC. It changes how we do business and such.
- According to the last business plan, IIT was supposed to focus on the global viability of this project while the University of Monterrey was supposed to focus locally in Mexico. We might need to revisit and reassert what we want to focus on.
- One of the important parts of the business plan succeeding seems to be increasing the villagers awareness of the issue of clean water and how it affects the quality of life. We should look into effective ways of doing that such as an outside agency that allows us to focus on other more serious aspects of the business.
- Also in terms of product definition, a lot of emphasis is placed on the clay filters, however are we also not involved with the plastic reservoirs and filter holders, as they are an integral part of the device. Where manufactured? How to market? We might need to do more research on the products and prices.
- Also, I was wondering in terms of the clay potters, do they pay to get trained and do we provide them with materials, or are they self reliant in getting materials, and lastly, how do we make sure they are accountable to produce quality filters.
- Competition search might need to be looked at again, to try and identify both the direct and the indirect competition for our product.
- More research on other water filtration systems to compare to our own and determine what differentiates us from those other systems.
- Patent issues: Have we looked into whether we are infringing on the patents held by other filter companies by trying to build our product.

AMANDA

- A lot of mention was given to companies and organizations who could potentially provide us with financial support. But how do we get their money? Do we make presentations, send mass letters hoping to get replies?

- Cost analysis was done on production of the filters. I'd like to know about the rest of the product, are we producing/marketing/selling the gaskets and containers as well? Will we be doing a finished product, or marketing the pieces separately?

Do the tanks get produced by the local people as well? Can they be recycled for US companies and shipped to Mexico for direct use? The same goes with the rubber gaskets.

- I think we have to target the customers first. Gain their interest, with demonstrations or seminars, and convince them they need a filter to live a healthy lifestyle. If the community starts to demand production and wants product, it will be easier to implement training sessions for the potters and get the whole community involved on a positive level rather than stuffing all the information down their throat and making them feel they have to comply. I think we really need to educate first, and market the product/products second.

- I'd like to see where we could take the product on a larger scale, not on a community wide system, but configurations useful for places of worship, schools, small businesses etc. The solution could be as simple as a collection of smaller filter systems. I'd like to at least explore the option.

- We should start small by really choosing the best areas to target. Establish a connection with those people, and hopefully the word will spread via local communication. We can't just say Mexico, we need a target audience to begin. As demand grows we can expand our operation.

- What kind of incentive can we give to the potters that will encourage them to make and sell our product? Do they make a profit on selling? How will that effect the price and willingness to purchase for the customer?

- Can maintenance of these systems be done directly by the owner or is special attention needed? Costs for repair men could be costly and we need to cut out the middle man if there is one. We want to promote something that not only encourages a healthier lifestyle, but is easy to afford and maintain for several years.

- I think we need to brainstorm better options for distribution that go beyond replying solely on the potters. What that solution is I'm not sure, but I'd like to at least discuss it.

- How is the silver, which is essential to removing bacteria from contaminated water, supplied to the potters? Are there local mines or does it have to be imported? Shipped, transported by train or truck or boat?

- I think we should target more than just mothers and their children. Clean water and help the elderly live more comfortable, and we can't forget about fathers who care equally for their children. It is necessary to get the whole community involved in order for the project to be a success. I don't think we should limit our target audience.

- A lot of time was spent explaining the multitude of ways in which new water supplies have been created for people living in rural areas. Is our company going to be a part of supply these new water supplies, or are we just going to concentrate our focus on supplying these new area wells with out water filtration system. Can we maybe do a joint venture with a company who specializes in new water supply systems so as to provide maximum education and efficiency in implementing our product into daily life?

- I think we should spend some time investigating how long it will take before the ideals take root and our product can be successfully implemented into their culture. HOW long will it take before we can turn a profit, etc? What is our expected initial investment to make it work? What is a potter's typical level of production? How many potters per village will we need to work with us?

I guess that's it for now. Sorry it's a lot. I look forward to talking about these issues next Tuesday. Have a good weekend.

CHRIS

As for the business plan...

We can go forward in two different ways.

1. Continue the implementation in Mexico
 - a. Do we need permits?
 - b. How are we going to actually get supplies where they need to be?
 - c. We should go more in depth for understanding their culture.
 - d. How do we get an educated person on the subject to go to rural areas and teach people...we need to account for their living expenses

2. Or we can model what they did and work on other rural areas such as India

DRAFT

4 MISSION STATEMENTS

KlarAqua's goal is to promote the general well being of people throughout the world. Our mission at KlarAqua is to provide 3rd world countries with the tools to build a low cost stand alone water purification system primarily through support and education from KlarAqua representatives.

KlarAqua is a non-profit organization devoted to improving health in rural areas of Mexico in a sustainable manner through the design of a low-cost, clay-based water purification system which can be locally produced and distributed. KlarAqua's water purification system eliminates major health-related contaminants such as nitrates and bacteria, which are responsible for most water borne illnesses. KlarAqua promotes sustainable local economic growth, by offering training to local potters which mobilizes them to create a product for which there is a significant market.

Klaraqua as a company is concerned with the educating of rural communities about the benefits of safe drinking water and providing them with the necessary training, tools and abilities such that we set a framework upon which they are able to develop into a healthier, more sustainable community in health and economy.

One child dies every 30 seconds from water-borne diseases in rural areas, a statistic that is not only frightening but distressing due to the fact it is not by choice. In such locations purified water is not readily accessible, poverty prevents the inhabitants from acquiring purification apparatuses, and the lack of education inhibits the population from understanding the problem and learning the proper techniques to minimize impure water consequences. It is the mission of KlarAqua, a not-for-profit organization, to develop and implement a water purification system that stimulates the community's economic growth and promotes sustainability by encouraging local craftsman to participate in the manufacturing process of the product creating income for them while promoting beneficial health care practices for others. By utilizing local materials and production techniques, KlarAqua will develop a system of water purification that is affordable, highly effective, and self-sustaining for the surrounding community for years to come.

APPENDIX – TEAM (3)

FIRST SET OF QUESTIONS SENT TO MONTERREY TEC ON FRIDAY, FEB 17th

REPORT FROM MONTERREY TEC RECEIVED ON FEB 24th

QUESTIONS FOR PILOT STUDY

Illinois Institute of Technology

MARKETING

- Where, when and how often does the community hold general meetings?
 - Who coordinates them?
- Is there a community leader? If so, who is he/she? Does he/she hold a political position?
- Are there other places where people meet together regularly? E.g., post office, school, clinic, church, etc.
 - How often?
- Has there been a similar study performed? If so, by who?

COSTS

- How much do they spend a month on water services? -- \$10 - \$50 pesos per week

RESOURCES

- Are there local potters? If so, who are they? Can we get their contact info?
- Is clay easily accessible? Do people dig it out?
- Are there enough local clay resources for mass production?

AWARENESS

- Are they concerned about contaminated water?
- Where do people get info about safe drinking water (is it taught in schools? learned from their parents?)
- Are they willing to purchase KlarAqua's water filter?

CONSUMPTION

- How much water is consumed per day?
- Where do they get it from?

STORAGE

- How do they store water? --
- What kind of containers are used?
- What size are the containers used?

DEMOGRAPHICS

- How many children are there per house hold?
- What are their ages?
- Do they attend school?
- What is the house income?
- What is the average education level? E.g., can they read? 92% literacy
-

ALTERNATIVES

- What do they usually drink in every meal (breakfast, lunch, dinner)?

HEALTH

- How often do they suffer from diarrhea?
- Have they heard of local deaths due to contaminated water?
- Per year, how much do they spend on doctor visits due to diarrhea or contaminated water?

APPENDIX – TEAM (4)

SECOND SET OF QUESTIONS (MARKETING) TO MONTERREY TEC

SENT ON FEBRUARY 28, 2006.

(NO RESPONSE RECEIVED AS OF 9 MARCH 2006)

Hola Pamela y Marcela!

Espero todo marche bien con sus estudios! Yo por aca tratando de tener un buen reporte para este proyecto de KlarAqua. Y ustedes que tal? Como sigue todo? Tienen algunas dudas or necesitan ayuda en algo?

Acerca de KlarAqua, me gustaria pedirles otro favor. Podria alguien ayudarme a conseguir respuestas para las siguientes preguntas? Por el momento, estoy tratando de enfocarme en el 'marketing and communications strategy'. Cualquier ayuda, se los agradeceria mucho. Mi professor quiere un reporte para el Lunes que viene, espero alguien pueda ayudarme or ponerme en buena direccion. Aqui estan las preguntas (por favor disculpen el 'mix' de languages):

- 1. How much does it cost (in Monterrey) to have an ad on a billboard?**
- 2. How much does it cost to have a graphics designer design our billboard?**
- 3. How much does a TV commercial cost?**
- 4. How much does a Radio commercial cost?**
- 5. How much does a newspaper, magazine ad cost?**
- 6. How much would it cost to have 5 people standing on the corner distributing flyers (cost per person)?**
- 7. How much does it cost to send people to communities to educate them about our product?**
- 8. Given Monterrey's culture, do you have any ideas or suggestions on what the "message" should be (to be used in advertising)?**
- 9. How many families were surveyed during the pilot study?**
- 10. What are their ages, education, etc?**

Al proposito, recibieron mis preguntas que les envie? Mi equipo me dijo que durante la junta de el Martes pasado direjon ustedes que enviarian el reporte de su 'pilot study' pronto! Nos tienen muriendonos de la curiosidad!! Tienen alguna fecha fija para enviarlo?

Esto es todo por el momento. Espero me puedan contestar. Tambien, por favor dejemos saber si necesitan algo or cualquier duda que tengan.

Saludos,

Esmeralda

APPENDIX – TEAM (5)

THIRD SET OF QUESTIONS

NOT SENT YET -- WAITING FOR FEEDBACK FROM PROF. KHALILI AS OF 9 MAR

**COVER LETTER FOR SECOND SET OF QUESTIONS
FOR MONTERREY TECH**

Dear Team Members:

Thank you very much for your reports. You provided us with very good data. As a result, we have answered some of our questions and as you can imagine, we have come up with some more questions.

Attached please find a document with our current questions. Also, would you please let us know the following dates:

- **Last day of classes (end of semester in Monterrey Tech)**
- **Future Pilot studies and targeted locations**
- **And estimated date for sending answers to our new attached list of questions.**

Thank you very much,

Esmeralda

THIRD SET OF QUESTONS FOR MONTERREY TECH

QUESTIONS FROM PILOT STUDY

Illinois Institute of Technology

QUESTIONS BASED ON REPORT SUBMITTED TO US BY MONTERREY TEC

APPENDIX 1

- In the population surveys, what does “population that drinks bottled water” mean? Do they drink *only* bottled water, or do they just drink it on occasion?

REPORT

Page 2:

What does it mean “All the population has tube water”? Does that mean they have water coming to their home through pipes? Is this water safe? How much does it cost for this service?

Page 4:

What is the purpose of visiting the South of the State to test the filter? Is water there worse? Is that a more rural area?

ADDITIONAL QUESTIONS

DESIGN

- Can we schedule a delivery date for us to send our current design (1 pot + 2 flat filters) to get local potter’s estimated cost and feedback?

MARKETING

- Are local inhabitants willing to travel distances to purchase the filter? Will it be culturally relevant for them to want to use it?
- How receptive are they to outside (foreign) influence?
- Are they more inclined to purchase products made and sold by local craftsman?

COST AND POTTER RESOURCES

- If shown the size of the filters the system requires, how many of each size and type could they produce a day? What hours do they work each day?
- What would they charge for each size and type of filter?
- How much does a 5 gallon bucket cost in Mexico?
- How much would the colloidal silver cost, material wise and cost of shipping and distribution?
- With the other products the potters produce, how much time (a couple of hours, one day per week) can they devote to the production of our product along with what they already produce?

AWARENESS

- Do people know what kind of diseases they can contract from contaminated water? Do they know the symptoms?
- Do local clinics just treat and release, or do they educate as well?

CONSUMPTION

- How much water is consumed for each person/day/use? (drinking, cooking, hygiene, etc.) of course it varies between adults and children, helpful to know for different size households
- How much time can they afford to devote to water purification practices? Do they see a benefit in the ease of use of our product? Will that make them want to use our product?
- How far away do they have to travel to get to water resources? Do they make several trips a day? How can we limit this?

DEMOGRAPHICS

- How much extra \$ do they have to spend each month, or week, after all other living purchases have been made?

ALTERNATIVES

- What is their preferred choice of liquid to consume? How much does this product cost? Where is it available for them to purchase? How often do they purchase it?

HEALTH

- Can they afford to go to clinics when sick? Who pays for their visits?
- Do they travel to clinics by car, bus, bike, foot?
- What are the local treatments for diseases...pills, liquid medication, shot, new diet?

COMMUNICATON

What are the cheapest and most effective modes of communication?

Who is the key leadership or influencer?

How can we effectively train the Potters?

Do you have any suggestions regarding how to market our idea and our vision effectively in such a way that is culturally acceptable as well as economically feasible?

APPENDIX – LAURA (1)

Laura's Progress Report as of 2/28/06

Activities:

1. Mission Statement (completed 1/30/06)
Drafted preliminary version, discussed key words, revised to reflect discussion: 2 hours
2. P3 Grant Proposal (completed 2/20/06)
Composed 16 page grant proposal, included meeting with various advisors for collaboration and reading all the documents from last semester: 20+ hours
3. Monterrey Pilot Study (completed 2/21/06)
Sending questions to Monterrey team for their pilot study: 1 hour
4. NCIIA Conference (continuing work)
Team registration, writing project summary for PR brochure, participating in an interview regarding my expectations of the conference, communication with conference host about AV equipment: 3 hours
5. I2P Competition (continuing work)
Meeting with Amanda and Prof Khalili to determine "game plan" for the competition, writing 5 page project summary of project: 3 hours
6. Other (continuing work)
 - reading Jake's H2O statistics CD
 - reading "The Fortune At the Bottom of The Pyramid"
 - search for qualifying grants (currently working on COS grant)
 - serving as contact for iKnow tech support
 - serving as resource for Raj's proposal for Fall 2006 continuation of IPRO

CURRENT ACCOMPLISHMENTS

- I have attended all design and business team meetings except for 2 due to personal reasons already explained to Professor Khalili
- Helped to develop KlarAqua's mission statement **0.5 hours**
- Did some preliminary research on our competitors with other filtration systems already on the market **1 hour**
 - Zenon Environmental Inc. (www.zenon.com) They use nanofiltration, microfiltration, ultrafiltration and reverse osmosis based systems. They utilize hollow fiber membrane strands and stainless steel mesh filters coated with granular activated carbon. They have a 95% efficiency in removing bacteria, taste, and odor problems. The products are easily transportable and have a high quality exceeding government regulations. Most of their products have a high initial cost, but maintenance required is low saving costs in the long run. They are currently involved in "Water for Humanity", an outreach program that provides no capital cost to the community for water filtration systems. They currently have operations in Canada, Vietnam, and South Africa looking to expand.



- UV Waterworks (waterhealth.com) A larger scale water purification system meant for communities serving up to 3000 people with up to 20 liters per person per day. The UV Waterworks component of the system treats bacteria, taste, odor, and color by applying ultraviolet light to contaminated water. One disadvantage is that it must be powered by electricity. It can disinfect 4 gallons/minute at a cost of 5 cents for 1,000 gallons. They currently have stations located in North and South America and in parts of Asia and Africa as well.

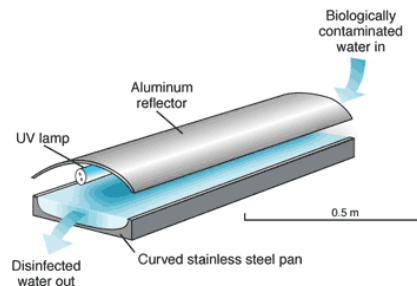

- Looked for more monetary opportunities on www.smartmoney.com without success **0.5 hours**
- Worked on new designs/directions for KlarAqua's logo, still in development **7.75 hours**
 - I decided to work on new logo designs because the one developed last semester seemed a bit unprofessional. We want something that is culturally relative to Mexico without being offensive, and a design that can be taken seriously and presented to corporations in the US when we submit grant proposals and make presentations. We need to have an equal effect in both areas of our project. We also need a logo that can be easily developed into a marketing strategies and products for use in demonstrations.
- Consultations with Adrian about the design of the filtration system along with development of 3D models **4 hours**
 - Since we are manufacturing a casing and filters to go inside the 5 gallon bucket, we cannot use the original cover in our filter system. I suggested a cloth covering that can be easily made, maybe by a textile worker in Mexico. It provides flexibility and a way to protect against debris falling into the top reservoir (bugs, dirt, etc).
 - We also had a discussion about putting the valve of the system on the bottom of the bucket. This way, as the water is filtered it can be poured into a container without having to

be tipped on its side kind of like how you have to tip large Gatorade containers to get the last couple of glasses out of it.

- Work with John Kriegshauser, manager of the Crown model shop, to devise ways of casting the plastic casing for the filter **2 hours**
 - The vacuum-former currently in the Crown Hall model shop is too small to manufacture the plastic casing full scale. We can use to do scale mock-ups, but we have to build an entirely new system including frame and heating apparatus to cast a piece that can be used for our final prototype.
- Revisions to a one page abstract **1.5 hours**
- Formulated and compiled questions and comments based on the results of Mexico's first pilot study for use in their next outing **1.5 hours**
- Begun a preliminary design for a brochure to hand out to professionals at business meetings and grant competitions **4.5 hours**
- Formal progress reports, 4 so far, and midterm progress report and powerpoint presentation **3.5 hours**

EXPECTED WORK

- On Tuesday March 8th: Half scale plastic casing prototype made in the Crown Hall model shop using the vacuum former and styrene **3 HOURS**

TOTAL TIME: ± 29.75 HOURS (not including time spent reading most of the uploaded files from last semester and new research compiled this semester)

NEXT STEPS

- Refining brochure design for presentations and competitions, start of one for use in Mexico
- Finalizing graphics for filter design
- ½ scale mock-up prototype of plastic casing
- I will also begin the re-designing of the posters for presentations
- Start working on the animation we will use for our competition in San Jose
- Final prototype of plastic casing cast

Investigation into the possible types of clay in Mexico and what would be the most suitable clay to go with in terms of availability to potters, cost and ease of use.

Background on Clay.¹

The term *clay* refers to a number of earthy materials that are composed of minerals rich in alumina, silica and water. Clay is not a single mineral, but a number of minerals. When most clay is wet, they become "plastic" meaning they can be formed and molded into shapes. When they are "fired" (exposed to very high temperatures), the water is driven off and they become as hard as stone. Clay is easily found all over the world. As a result, nearly all civilizations have used some form of clay for everything from bricks to pottery to tablets for recording business transactions.

The minerals that make up clay are so fine that until the invention of X-ray diffraction analysis, these minerals were not specifically known. Under extremely high magnification, one can see that clay minerals can be shaped like flakes, fibers, and even hollow tubes. *Clays can also contain other materials such as iron oxide (rust), silica, and rock fragments.* These impurities can change the characteristics of the clay. For example, iron oxide colors clay red. The presence of silica increases the plasticity of the clay (that is, makes it easier to mold and form into shapes).

Clays are categorized into six categories in industry. These categories are ball clay, bentonite, common clay, fire clay, fuller's earth, and kaolin.

Sources¹

Clays are common all over the world. Some regions, as might be expected, produce large quantities of specific types of clay. It is estimated that the state of Georgia has kaolin clay reserves of 5 to 10 billion tons. The United States is self-sufficient so it imports only small amounts of clay from Mexico, Brazil, United Kingdom, Canada, and assorted other nations. The United States exports nearly half of its production worldwide.

The nations producing the most significant amounts of the various clays are as follows:

- **Kaolin:**
Brazil, United Kingdom, and the United States are the dominant producers of high quality kaolin.
- **Ball clays:**
Major producers of ball clays are Germany, the United States, United Kingdom, the Czech Republic, China, and France.
- **Fire clays:**
Major fire clay producing countries are Germany, and the United States.
- **Bentonite:**
Major producers of bentonite are the United States, Germany, Turkey, and Greece.
- **Fuller's earth:**
Major producers of fuller's earth are the United States (attapulgitite, smectite), Spain (attapulgitite, sepiolite), and Senegal (attapulgitite).

It is clear that the USA has the most reserves of a lot of clay and it might be worth investigating the possibility of them exporting the clay to Mexico for use in the business.

Uses¹

The United States both imports and exports clays and clay products. It is estimated that the United States consumes about 37.6 million tons of clays each year.

Ball clays are good quality clays used mostly in pottery but are also added to other clays to improve their plasticity. Ball clays are not as common as other clay varieties. One third of the ball clay used annually is used to make floor and wall tiles. It is also used to make sanitary ware, pottery, and other uses.

Bentonite is formed from the alteration of volcanic ash. Bentonite is used in pet litter to absorb liquids. It is used as a mud in drilling applications. It is also used in other industrial applications such as the "pelletizing" of iron ore.

Common clay is used to make construction materials such as bricks, cement, and lightweight aggregates.

Fire clays are all clays (excluding bentonite and ball clays) that are used to make items resistant to extreme heat. These products are called *refractory* products. Nearly all (81%) of fire clays are used to make refractory products.

Fuller's earth is composed of the mineral palygorskite (at one time this mineral was called "attapulgitite"). Fuller's earth is used mostly as an absorbent material (74%), but also for pesticides and pesticide-related products (6%).

Kaolinite is a clay composed of the mineral *kaolin*. It is an essential ingredient in the production of high quality paper and some refractory porcelain.

It seems from the information gathered that ball clay is the most plastic and useful clay for pottery closely followed by Bentonite which has high absorption rates and is porous and therefore might be good for our purposes.

Substitutes and Alternative Sources

When necessary, calcium carbonate and talc can be used in place of clay as filler in some applications. However, clay is so abundant in all its forms that such substitutions may only be necessary if the alternative materials are less expensive than clay (which is not very likely).

Types of clay in México:

The common surface clay can be found all over the country. It can be found in a yard, the beach, the desert or near the mountains.²

Biggest Deposits: In the state of Durango, at the north of the country, are the biggest clay deposits. The clay in Durango is *bentonite* (the commercial name for *montmorillonite* clay).² There are also other important deposits in several states, like in Puebla, Oaxaca, Tlaxcala, Zacatecas and Guanajuato, but the composition of the clay varies. It contains great amounts of iron and the color changes from red ochre to black. The clay found in these places is ferruginous.²

U.S. production of clays in 2004 (including ball clay, bentonite, common clay and shale, fire clay, fuller's earth, and kaolin) rose 18% to 49 million tons valued at \$1.7 billion. Major domestic uses for specific clays were estimated as follows: ball clay-31% floor and wall tile, 20% sanitaryware and 49% other uses; bentonite-25% pet waste absorbent, 20% drilling mud, 19% foundry sand bond, 13% iron ore pelletizing and 23% other uses; common clay-55% brick, 19% cement, 16% lightweight aggregate and 10% other uses; fire clay-79% refractories and 21% other uses; fuller's earth-76% absorbent uses and 24% other uses; and kaolin-54% paper, 14% refractories and 32% other uses.³

Imports of clays for consumption decreased to an estimated 225,000 tons. The major sources of imported clay were Brazil (kaolin), Canada (bentonite), Mexico (activated clay) and the UK (kaolin). Exports increased to 5.6 million tons. Major markets for exported clays, by descending order of tonnage, were Canada, Japan, Mexico, Finland and Taiwan.³

Effects of Kaolin and Bentonite on Humans;⁴

I think this is important for potters as over time, their health might be jeopardized by the type of clay they are exposed to.

General population exposure to low concentrations of montmorillonite and kaolinite, the main components of bentonite and kaolin, respectively, and other clay minerals is ubiquitous. There is no information on the possible effects of such low-level exposure.

Long-term occupational exposures to bentonite dust may cause structural and functional damage to the lungs. However, available data are inadequate to conclusively establish a dose–response relationship or even a cause-and-effect relationship due to limited information on period and intensity of exposure and to confounding factors, such as exposure to silica and tobacco smoke.

Long-term exposure to kaolin causes the development of radiologically diagnosed pneumoconiosis in an exposure-related fashion. Clear-cut deterioration of respiratory function and related symptoms have been reported only in cases with prominent radiological findings. The composition of the clay — i.e., quantity and quality of minerals other than kaolinite — is an important determinant of the effects.

Bentonite, kaolin, and other clays often contain quartz, and exposure to quartz is causally related to silicosis and lung cancer. Statistically significant increases in the incidence of or mortality from chronic bronchitis and pulmonary emphysema have been reported after exposure to quartz.

Reference 1:

Mineral Information Institute.

<http://www.mii.org/Minerals/photoclay.html>

Reference 2:

Domínguez, J.M. & I. Schifter. *Las arcillas: el barro noble*. Fondo de Cultura Económica. México, 1995

Reference 3:

Ceramic Industry, Raw and Manufactured Materials 2006 Overview.

<http://www.ceramicindustry.com/>

Reference 4:

Environmental Health Criteria 231: BENTONITE, KAOLIN, AND SELECTED CLAY MINERALS

<http://www.inchem.org/documents/ehc/ehc/ehc231.htm>

APPENDIX – SEUN (2)

Oluwaseun Craig.
IPRO 355: Spring 2006
March 6, 2006

Progress Report for the week from February 26th to March 6, 2006.

Some of the progress made so far since the last progress report include the following:

- Read all the pertinent documents from Blackboard and made up a comments follow up on the Mexico Report. *(3 hrs)*
- Prepared questions for Mexico to use on the follow up case study if they have the funds to go somewhere else which will give better information. *(1 hr)*
- Met up with Chris and went to the Downtown campus to meet Professor Dianne Cernacues. *(1hr)*
- Worked on my individual elements for the midterm report. Including proof reading and modifications *(3 hrs)*
- Worked on my individual slides for the midterm report *(2 hrs)*
- Practice for the midterm presentation *(1 hr)*

Approximate total time spent this week outside class and team meetings: **11 hours**

APPENDIX – SEUN (3)

Oluwaseun Craig
IPRO 355: Spring 2006

March 2, 2006

Questions for Mexico after the Initial Pilot Study.

1. What are some of the common alternatives for getting water including the sources or the methods?
2. Is there some other sort of local filtration process used by the community?
3. Is there any distribution channel to deliver things to the community?
4. Ask the community what are some of the things they would like in terms of a filtration device as well as what they will absolutely not like. Is it possible to have some central location where this device can be located like churches, schools or the hospitals so that everyone can always get there and decide if it is worth investing in their homes?
5. How much are they willing to spend if it saves them on hospital visits and sickness?
6. Ask the Potters if they would like to be in charge of storing the filters and possibly other parts of the device as well as what kind of resources they would need in order to consider becoming a Klaraqua potter.
7. Have the communities had any previous exposure to NGO's or Not for Profits like ours which have tried to inform them about the benefits of clean drinking water.

APPENDIX -- CHRIS

Chris Primozic
February 28, 2006
Progress report

Mission statement:

KlarAqua's goal is to promote the general well being of people throughout the world. Our mission at KlarAqua is to provide 3rd world countries with the tools to build a low cost stand alone water purification system primarily through support and education from KlarAqua representatives.

It was later revamped into our current mission statement

Here is the statistics I was talking about never wrote up

Improved drinking water

Total 91%

Urban 97%

Rural 72%

*Improved drinking water does mean perfect. The water is improved but contains smaller amounts of contaminants

Literacy

Adult Males 92%

Adult Females 89%

Demographics (thousands)

Under 18 39787

Under 5 10962

Growth rate (year)

70-90 2.6%

90-04 1.6%

Death Rate (year)

70 10%

90 8%

04 4%

Birth Rate (year)

70 45%

90 29%

04 21%

Life Expectancy (year)

70 61

90 71

04 75

Economics

GNI per capita \$6,770

Average % of inflation

Form 90-04 16%

Percent population below 1\$ a day 10%

Government Spending 93-04

Percent on Health 5%

Percent on Education 25%

Questions for pilot study

1. How often are doctor visits because of water related illnesses?
2. Who pays for the visits? (NGO's)
3. Do people need to travel to see a doctor? (There are small hospitals in communities or something similar, there are supplies for treating illnesses there also)
4. Are people aware of the health problems relating to water?
5. Are there community leaders?
6. Do people have a way to travel?
7. Is there s disposable income?
8. Who is in charge of getting water? (Men/Women/Kids) (most likely women)

*anything in () is an answer I found during out conference calling

I have also talked to Amanda about a few ideas for the logo for out company

My idea was to maybe have a goldfish in a bag that was filled or being filled by the water coming out of our product. However the more that I think about it, it probably does not relate to their culture as much as ours.

Seun and myself are planning to go on a Friday, maybe this Friday to meet with the person at the down town campus to do a cash flow analysis and finish up or get a good start on the cost benefit analysis

APPENDIX -- ESMERALDA

PERFORMANCE REPORT – Feb 10, 2006

Esmeralda Jimenez

- Submitted GE Business Proposal
- Held Weekly meetings on Tuesdays
- Mission Statement
 - Asked each member to submit first draft
 - Asked each member to submit a second draft
 - Developed a final draft
- Communicated with Mexico's Team
- Met with Prof. Bradband to discuss project
- Developed a business status and strategy
- Met with Kailas to discuss status
 - Emailed Kailas business situation
- Emailed GE proposal description to Laura for P3
- Assigned individual tasks
 - Seun (competitive positioning)
 - Amanda (Go-to-market readiness)
 - Laura (Funding)
 - Chris (Market and Customer situation)
 - Me: Market messaging; marketing plan
- Emailed 4 questions for videoconference
- Attended Videoconference call

FUTURE TASKS

Meet with Adrian to answer the following questions (Per Prof. Khalili's request)

Work with Adrian – define and document:

(1) project goals and objectives

(2) measurables

(3) responsibilities/tasks to be undertaken by each team member

(4) a strategy for performance evaluation.

We need these items by next. Tuesday posted.

- Assign big project to Kailas
- Touch base with Mexico's business team to find out what materials, questions, etc. they will be using for the Pilot Study to be held in Pesqueria Municipio (end of February).
- Add my own questions to Mexico's Pilot Study *survey*
- Write final report on (managerial suggestions for future teams)
- Compile final business plan